



The Safety Compendium

PILZ
THE SPIRIT OF SAFETY

For the application of functional safety standards.



► The Safety Compendium

1	Preface
1.1	Authors
2	Product liability
3	Standards, directives and laws
3.1	Standards, directives and laws in the European Union (EU)
3.2	CE marking
3.3	Directives
3.4	Standards
3.5	International comparison of standards, directives and laws
3.6	Industrial robots, human-robot collaboration (HRC)
3.7	Safe programming in accordance with EN ISO 13849-1
3.8	Validation
3.9	Certification and accreditation
4	Safeguards
4.1	European Union standards, directives and laws relating to safeguards
4.2	Guards
4.3	Protective devices
4.4	Manipulation of safeguards
5	Safe control technology
5.1	Safety relays
5.2	Configurable safe small controllers
5.3	Safety and automation
5.4	Using safety controllers to achieve safe control technology
5.5	Safe control technology in transition
6	Safe communication
6.1	Basic principles of safety-related communication
6.2	Safe Ethernet communication with SafetyNET p

► The Safety Compendium

- 7 Safe motion**
 - 7.1 Definition of safe motion
 - 7.2 Basic principle
 - 7.3 Standard EN 61800-5-2
 - 7.4 Safety functions
 - 7.5 System examination
 - 7.6 Examples of safe motion

- 8 Mechanical, pneumatic and hydraulic design**
 - 8.1 Introduction to mechanical, pneumatic and hydraulic design
 - 8.2 Mechanical design
 - 8.3 Pneumatic design
 - 8.4 Hydraulic design
 - 8.5 Safety requirements on hydraulic circuits

- 9 Appendix**
 - 9.1 Index
 - 9.2 Exclusion of liability



1

Preface



▶ 1 Preface

1	Preface	
1.1	Authors	1-4

► 1 Preface

Its presence is always assumed; only when it is absent is it actually noticed: safety. It has the task of protecting people, machinery and the environment.

Mechanisation heralded in the first industrial revolution when Edmund Cartwright introduced the first weaving looms in 1787. Back then, the main motivation was to increase productivity and barely anyone spared a thought for the safety of the weaver. By contrast, today the spotlight is focused equally on the efficiency of the production process and the safety of the person.

In addition to communicating actual normative and technical principles, an important part of the Safety Compendium is therefore highlighting the numerous relationships between safety and economy. The old saying is true: if safety is taken into account and correctly dimensioned from the very start, it automatically leads to efficient procedures and high acceptance by the user.

This 5th edition is not simply a newly printed, updated version. Our experts have expanded this Safety Compendium, now recognised as a standard work, to include current topics such as 'Safety in Industrie 4.0' and 'Human-robot collaboration'.

After all, digital data and its efficient exchange will define the production process of the smart factory in the future. There is a growing need here for secure communication, which encompasses aspects of machinery safety on the one hand

and requirements such as data and IT security on the other. And finally, the role of the human is being reinterpreted in the smart factory: the human's particular skills contribute to making production better and even more efficient. In many areas, such as robotics, this means that the human is closer to the machine or that human and machine share a workspace. The Safety Compendium clarifies the requirements this places on safety and explains how these can be met.

Safety is no longer regarded as merely a normative obligation that is at odds with the objectives of efficiency or user-friendliness. Rather, mature safety is today an incredibly important prerequisite for making production available and efficient.

In this spirit I sincerely hope that reading the Safety Compendium is a productive experience.



Renate Pilz
Managing Partner
Pilz GmbH & Co. KG

▶ 1.1 Authors



Christian Bittner, Group Manager of the Consulting Services Group within Pilz GmbH & Co. KG, he is a member of the standards committee for EN ISO 12100, amongst others. He is in direct contact with customers: his duties include performing risk assessments, producing safety concepts, CE marking and other safety services.



Holger Bode is responsible for international project planning for press upgrades and new installations in the Presses working group at Pilz GmbH & Co. KG. Responsibilities include the development of full conversion measures as well as the production of control concepts, hazard assessments and safety concepts. He is also the Quality Manager of the accredited inspection body at Pilz GmbH & Co. KG and is part of the management team.



Arndt Christ is Head of the Customer Support Department at Pilz GmbH & Co. KG. Within the department he is responsible for groups such as Technical Support and the consulting units, as well as system integration and the training team. He is familiar with customers' requirements on all safety-related subjects, and so guarantees a user-friendly implementation in the field of safety technology.



Roland Gaiser is Head of the Actuator Systems division in development at Pilz GmbH & Co. KG. He also lectures on system development and simulation at the Faculty of Mechatronics and Electrical Engineering at Esslingen University. He has extensive knowledge in the field of basic development of actuator systems.



Andreas Hahn is the Senior Manager for Networks, Control Systems and Actuator Technology in Product Management at Pilz GmbH & Co. KG. He is a member of standards committees and working groups for various associations. He has many years' experience in the design of automation solutions.

► 1.1 Authors



Jürgen Hasel is a trainer and consultant at Festo Didactic SE.

His seminars focus on pneumatics, electropneumatics, valve terminals and safety technology. Earlier in his career he worked in the development department at Festo AG. He has been working closely with the training department of Pilz GmbH & Co. KG for some years. At Pilz he teaches the CMSE course (Certified Machinery Safety Expert) certified by TÜV Nord, as part of product-neutral training.



Prof. Dr. Thomas Klindt is a partner at the international law firm NOERR and is also honorary professor for Product and Technology Law at the University of Bayreuth. He is a member of the chamber's internal product safety & product liability practice group, which oversees national and international product liability processes, product recalls and compensation claims.



Michael Moog is the Standardisation Specialist at Pilz GmbH & Co. KG and in this role is responsible for coordination of the international standards committee work. He himself is active in standards committees and combines theoretical work with practical interpretation of standards for support within Pilz and for customers. He specifically deals with the safety and product standardisation to be observed worldwide along with the corresponding legal frameworks for particular countries and shares his knowledge in seminars such as “Approval Procedures for Plant and Machinery in North America”.



Dr. Alfred Neudörfer was a lecturer in the Department of Mechanical Engineering at Technische Universität Darmstadt. He was also a guest professor in safety technology at Nagaoka University of Technology in Japan. The subject of many of his lectures, seminars and technical papers has been the design of safety-related products.



Andreas Schott is responsible for the Training and Education division within Pilz GmbH & Co. KG. As Group Manager, he works with his team to produce educational and practically relevant training concepts for both product-neutral and product-specific courses. His many years of experience as a state-approved electrical engineer and software programmer have familiarised him with the practical requirements of customers when it comes to safety technology.

▶ 1.1 Authors



Eszter Sieber-Fazakas, LL.M. is a lawyer with the international law firm NOERR. She is also a member of the chamber's internal product safety & product liability practice group, which oversees national and international product liability processes, product recalls and compensation claims.



Klaus Stark is responsible for the Innovation Management division at Pilz GmbH & Co. KG. He was previously Head of Product Management beginning in 1996, until he took over as Head of International Sales in 2008. He is actively involved in various committees in support of automation, such as his role as Chairman of the "Safety Systems in Automation" Technical Committee of the ZVEI or as a member of the Board of the technology initiative SmartFactory KL e. V.



Jochen Vetter is the Team Leader of Robotic Services at Pilz GmbH & Co. KG. He is in direct contact with customers: one of his tasks is to implement services regarding HRC, i.e.: the creation of risk assessments and safety concepts for HRC applications. With the acceptance of HRC applications, his tasks also include technical measurement checks of the biomechanical limit values in accordance with TS 15066.



Gerd Wemmer works as an application engineer in Customer Support at Pilz GmbH & Co. KG. He is responsible for consultancy, project engineering and the preparation of safety concepts for customers, from machine manufacturers to end users, and has many years of practical experience in safety technology.



Harald Wessels is Divisional Manager for cross-product issues in Product Management at Pilz GmbH & Co. KG. His tasks include participation in international standards committees that deal with communication in industrial applications. He has extensive knowledge of the fieldbus systems and networks that are used in automation.

▶ 1.1 Authors



Matthias Wimmer is active within the Pilz Standards Group to ensure informed handling of standards and regulations. He is a member of the international standards working group ISO/TC199/WG8 and plays a substantial role in shaping the development of standards for functional safety (including EN ISO 13849-1). He also imparts his knowledge to a broad audience, both inside and outside the company, through training courses and seminars in the Pilz Academy.



Michael Wustlich is Group Manager of the Software, Application and Tests division at Pilz GmbH & Co. KG. His duties include the development of user-level safety-related software in the form of standardised, certified products. Together with his team he is responsible for the specification and design of systemised application tests across all product groups.



2

Product liability



▶ 2 Product liability

The liability for faulty products was harmonised in Europe with the European Product Liability Directive 85/374/EEC. This statutory regulation took effect on 01.01.1990 and is only valid for products that have been placed on the market after this point in time. The previous product liability law developed based on case-law was not suspended by this directive; instead the provisions of the Product Liability Directive apply in addition to the previous rules of law. This is true not only for the German Product Liability Act, but also for the law of each individual member state (Art. 13 of the Product Liability Directive).

The Product Liability Directive leaves the member states much leeway for the implementation of their national liability regulations, e.g. this applies for the option of inclusion of liability for development risks (Article 15 para. 1 (B) of the Product Liability Directive). Luxembourg, Finland and, to a limited extent, France and Spain exercised this option. As to the question of whether the Product Liability Directive is only a minimum harmonisation, it must be noted that the European Court of Justice (ECJ) takes the position of full harmonisation according to consistent case-law. The member states are thereby prohibited from deviating from the directive and extending the liability beyond the standard defined by European law in the interest of consumer protection.

This ECJ decision for a particular legal aspect notwithstanding, the EU Product Liability Directive has still not been uniformly adopted as national law in the individual EU member states.

In addition to this, further product liability aspects relating to national contract, liability and/or civil law in the respective EU member state must also be taken into account when entering a market.

Such a complicated legal framework for the current 28 EU member states cannot be discussed in this Safety Compendium. The primary goal is relaying basic knowledge on European machinery safety.



3

Standards, directives and laws

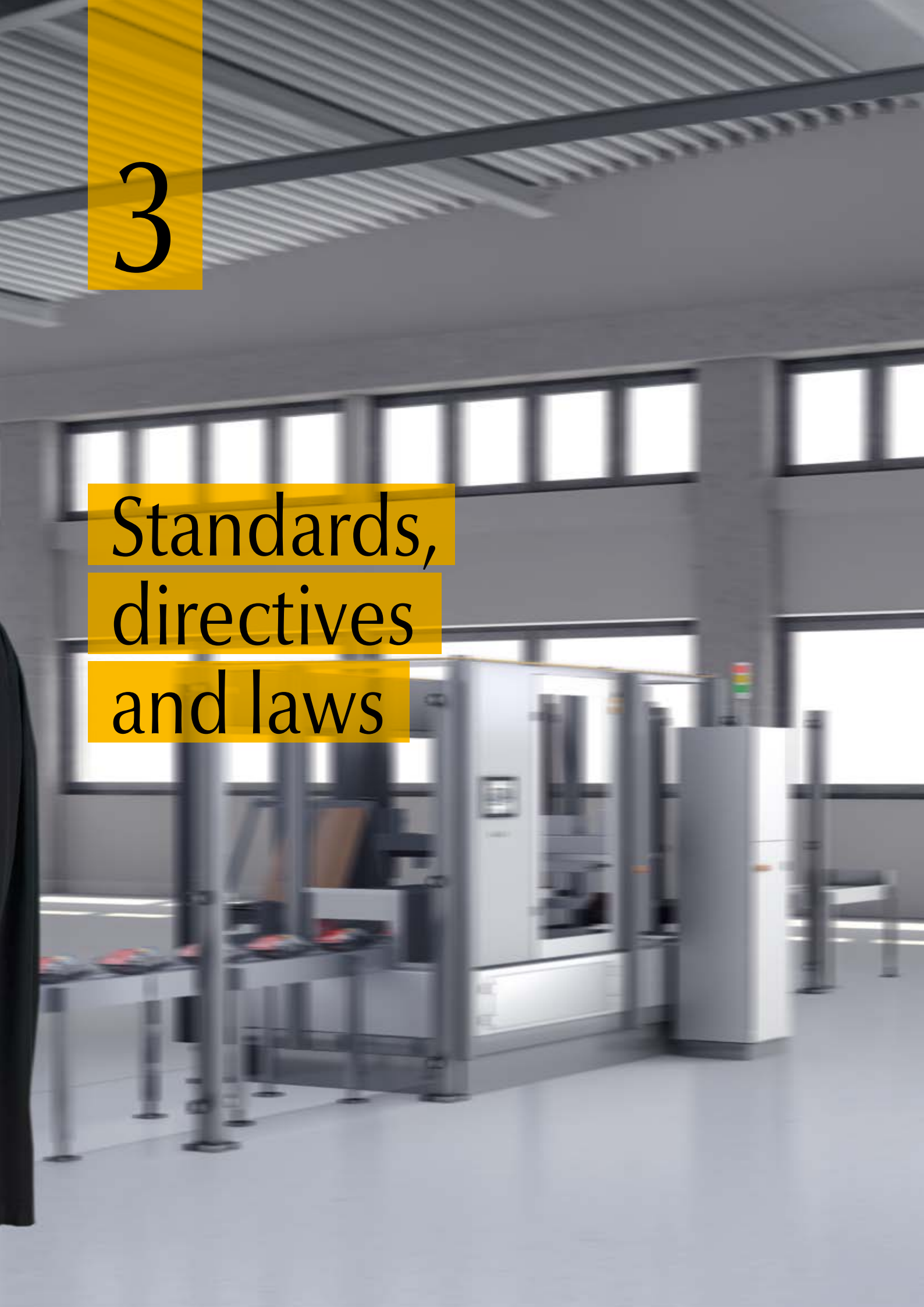

► 3 Standards, directives and laws

3	Standards, directives and laws	
3.1	Standards, directives and laws in the European Union (EU)	3-3
3.2	CE marking	3-5
3.2.1	The basis of machine safety: Machinery Directive and CE mark	3-5
3.2.2	Legal principles	3-5
3.2.3	CE marking of machinery	3-6
3.3	Directives	3-16
3.3.1	Machinery Directive	3-17
3.4	Standards	3-18
3.4.1	Publishers and scope	3-18
3.4.2	EN engineering safety standards	3-19
3.4.3	Generic standards and design specifications	3-21
3.4.4	Product standards	3-36
3.4.5	Application standards	3-39
3.5	International comparison of standards, directives and laws	3-40
3.5.1	Directives and laws in America	3-40
3.5.2	Directives and laws in Asia	3-45
3.5.3	Directives and laws in Oceania	3-49
3.5.4	Summary	3-51
3.6	Industrial robots, human-robot collaboration (HRC)	3-52
3.6.1	Normative specifications for the use of industrial robots	3-53
3.6.2	Robot applications from the perspective of EN ISO 10218-2	3-54
3.6.3	Human-robot collaboration and ISO/TS 15066	3-54
3.6.4	Validation	3-57
3.6.5	Purpose of the measurement	3-58
3.7	Safe programming in accordance with EN ISO 13849-1	3-60
3.7.1	Safety-related software	3-60
3.7.2	Software in relation to the risk assessment	3-61
3.7.3	Basic requirements for software development	3-62
3.7.4	Additional fault-prevention measures for increasing performance level	3-63
3.7.5	Programming tools, languages and libraries	3-63
3.7.6	Structuring and modularity of the software	3-63
3.7.7	SRASW and non-SRASW in a component	3-64
3.7.8	Software implementation and coding	3-64
3.7.9	Testing	3-65
3.7.10	Documentation	3-66
3.7.11	Verification	3-66
3.7.12	Configuration management	3-66
3.7.13	Changes	3-66
3.7.14	Summary	3-66

▶ 3 Standards, directives and laws

3.8	Validation _____	3-67
3.8.1	Verification of safety functions in accordance with EN ISO 13849-1/2 _____	3-68
3.8.2	Verification of safety functions in accordance with EN 62061 _____	3-68
3.8.3	General information about the validation plan _____	3-69
3.8.4	Validating through analysis _____	3-70
3.8.5	Validating through testing _____	3-70
3.8.6	Verification of safety functions _____	3-70
3.8.7	Validation of software _____	3-72
3.8.8	Validation of resistance to environmental requirements _____	3-73
3.8.9	Production of validation report _____	3-73
3.8.10	Conclusion _____	3-73
3.8.11	Appendix _____	3-74
3.9	Certification and accreditation _____	3-76
3.9.1	Accreditation: Quality seal for customers _____	3-76
3.9.2	Accreditation or certification _____	3-79
3.9.3	Tests in accordance with the Ordinance on Industrial Safety and accreditation _____	3-80
3.9.4	Conclusion _____	3-81

► 3.1 Standards, directives and laws in the European Union (EU)

The European Union is experiencing ever closer union. For machine builders, this translates into an increasing harmonisation of laws, rules and regulations. Not that long ago, each country published its own guidelines on the different areas of daily life and the economy, but today you'll find more and more standardised regulations within Europe.

How are European laws, directives and standards connected?

Initially, the EU formulates general safety objectives via directives. These safety objectives need to be specified more precisely; the actual provision is made via standards.

EU directives generally deal with specific issues. The directives themselves have no direct impact on individual citizens or companies. They only come into effect through the agreements of individual countries within the EU, who incorporate these directives into their domestic law. In each EU country, a law or regulation refers to the relevant EU directive and thus elevates it to the status of domestic law. Between the time a directive is

adopted and the point at which it is incorporated into domestic law there is inevitably a transition period, during which time the directive is incorporated into domestic law in the individual countries. However, for users this is generally unimportant because the directives themselves provide clear indication on the respective validity date. So although the titles of these documents describe them almost harmlessly as directives, in practice they have legal status within the EU.

This explains how laws and directives are connected, but doesn't deal with the issue of the standards.

Although the standards themselves make interesting reading, on their own they have no direct legal relevance until they are published in the Official Journal of the EU or are referenced in domestic laws and regulations. These are the publications by which a standard can acquire "presumption of conformity". Presumption of conformity means that a manufacturer can assume he has met the requirements of the corresponding directive that are covered by the standard provided he has complied with the specifications in the

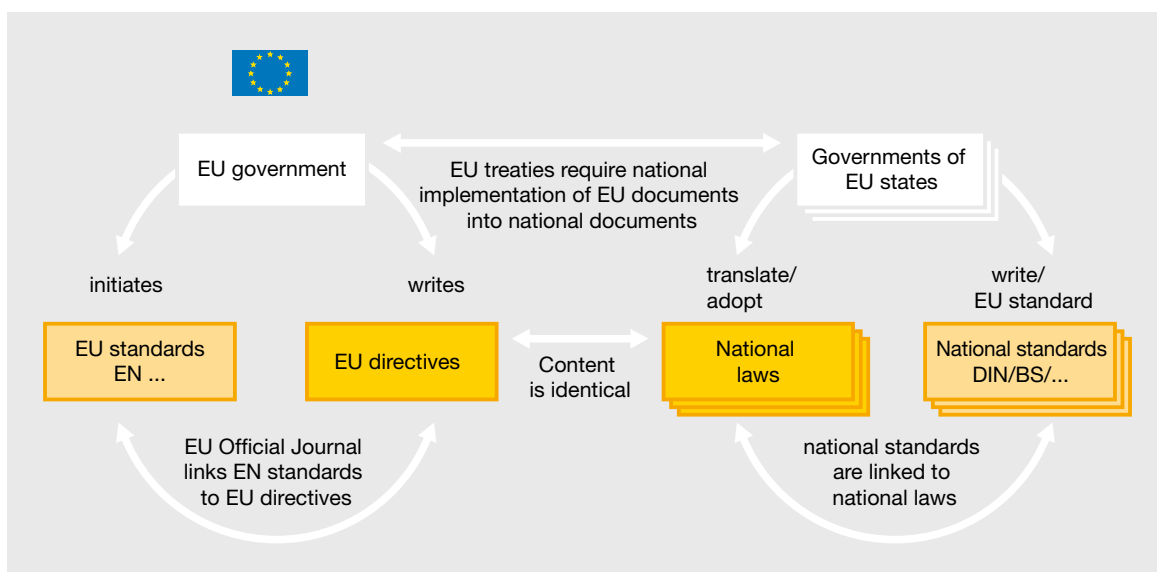

Relationship between harmonised standards and laws in the EU

▶ 3.1 Standards, directives and laws in the European Union (EU)

standard. So presumption of conformity confirms proper conduct, as it were. In a formal, legal context this is called a reversal of the burden of proof. Where the manufacturer applies a harmonised standard, if there is any doubt, misconduct will need to be proven. Where the manufacturer has not applied a harmonised standard, he will need to prove that he has acted in compliance with the directives.

If a manufacturer does not comply with a standard, it does not necessarily mean that he has acted incorrectly. Particularly in innovative industries, relevant standards either may not exist or may be inadequate. The manufacturer must then demonstrate independently that he has taken the necessary care to comply with the safety objectives of the relevant directives. Such a route is usually more complex but, in an innovative industry in particular, it is often unavoidable.

It's important to stress that the EU does not publish every standard in the Official Journal, so many are still not harmonised. Even if such a standard is deemed to have considerable technical relevance, it will still not have presumption of conformity. However, sometimes a standard that has not been listed in the EU Official Journal does achieve a status that's comparable with harmonisation. This is the case, for example, when a standard that's already been harmonised refers to the relevant standard. The standard that is not listed in the EU Official Journal is then harmonised "through the back door", as it were.

▶ 3.2 CE marking



3.2.1 The basis of machine safety: Machinery Directive and CE mark

When the Machinery Directive (MD) was ratified in 1993, the aim was to remove trade barriers and enable a free internal market within Europe. After a two-year transition period, the Machinery Directive has been binding in Europe since 01.01.1995. It describes standardised health and safety requirements for interaction between man and machine and replaces the host of individual state regulations that existed on machinery safety. The Machinery Directive 2006/42/EC has applied since 29.12.2009.

The CE mark stands for “Communauté Européenne”. A manufacturer uses this mark to document the fact that he has considered all the European internal market directives that are relevant to his product and applied all the appropriate conformity assessment procedures. Products that carry the CE mark may be imported and sold without considering national regulations. That’s why the CE mark is also referred to as the “Passport to Europe”.

Generally speaking, all directives in accordance with the new concept (“new approach”) provide for CE marking. Where a product falls under the scope of several directives which provide for CE marking, the marking indicates that the product is assumed to conform with the provisions of all these directives.

3.2.2 Legal principles

The obligation to affix CE marking extends to all products which fall under the scope of directives providing for such marking and which are destined for the single market. CE marking should therefore be affixed to the following products that fall under the scope of a directive:

- ▶ All new products, irrespective of whether they were manufactured in member states or third-party countries
- ▶ Used products imported from third-party countries and second hand products
- ▶ Products that have been substantially modified and fall under the scope of the directives as new products

The directives may exclude certain products from CE marking.

The manufacturer uses the EC declaration of conformity to confirm that his product meets the requirements of the relevant directive(s).

The information that follows is intended to explain CE marking in terms of the Machinery Directive.

▶ 3.2 CE marking

3.2.3 CE marking of machinery

3.2.3.1 What is a machine?

For the purposes of the Directive, one definition of a machine is:

An assembly of linked parts or components, at least one of which moves, and which are joined together for a specific application (see Article 2 of the Machinery Directive).

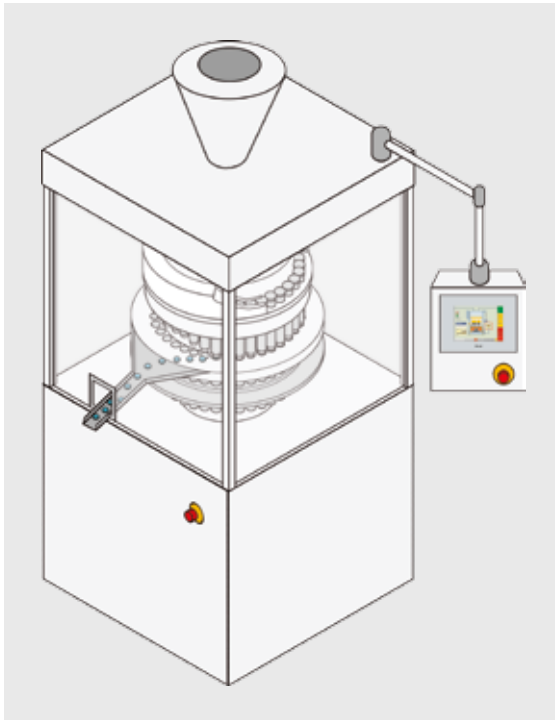

Example of a machine for the purposes of the Directive

The following are also considered as machines for the purposes of the Machinery Directive:

- ▶ An assembly of machines or complex plants (complex plants include production lines and special purpose machinery made up of several machines)

- ▶ Safety components (the issue of which components to classify as safety components is very controversial. Annex V of the Machinery Directive contains an extremely comprehensive list of safety components.)
- ▶ Interchangeable equipment that can modify the basic functions of a machine
- ▶ Partly completed machinery that is intended to be incorporated into other machines/machine parts, thereby forming machinery

3.2.3.2 CE-marking of plant and machinery

According to the Machinery Directive, a machine manufacturer is anyone who assembles machines or machine parts of various origins and places them on the market.

A manufacturer may be the actual machine builder or – where a machine is modified – the operator, who thereby becomes the manufacturer. In the case of assembled machinery, it may be the manufacturer, an assembler, the project manager, an engineering company or the operator himself who assembles a new installation from various machines so that the different machine parts constitute a new machine.

However, according to the Machinery Directive, only one manufacturer is responsible for the design and manufacture of the machine. This manufacturer or his authorised representative takes responsibility for implementing the administrative procedures for the entire plant. The manufacturer may appoint an authorised representative to assume responsibility for the necessary procedures for placing the product on the market:

- ▶ Compiling the plant's technical documentation
- ▶ Produce the technical documentation
- ▶ Providing operating instructions for the plant
- ▶ Affixing the CE mark in a suitable position on the plant and drawing up an EC declaration of conformity for the entire plant

▶ 3.2 CE marking

It's important that the manufacturer considers the safety aspect early, as the contracts are being formulated or in the components' requirement manual. The documentation shall not be compiled solely from the point of view of machine performance. The manufacturer is responsible for the whole of the technical documentation and must determine the part that each of his suppliers is to undertake in this process.

3.2.3.3 Use of machinery in the European Economic Area

Irrespective of the place and date of manufacture, all machinery used in the European Economic Area for the first time from 01.01.1995 is subject to the EU Machinery Directive and as such must be CE certified.

3.2.3.4 Assembled machinery

On large production lines a machine may often consist of several individual machines assembled together. Even if each of these bears its own CE mark, the overall plant must still undergo a CE marking process.

3.2.3.5 Importing a machine from a country outside the EU

When a machine is imported from a third country for use within the EU, that machine must comply with the Machinery Directive when it is made available on the EU market. Anyone who places a machine on the market for the first time within the European Economic Area must have the necessary documentation to establish conformity, or have access to such documentation. This applies whether you are dealing with an "old machine" or new machinery.

3.2.3.6 Machinery for own use

The Machinery Directive also obliges users who manufacture machinery for their own use to comply with the Directive. Although there are no problems in terms of free trade - after all, the machine is not to be traded - the Machinery Directive is applied to guarantee that the safety level of the new machine matches that of other machines available on the market.

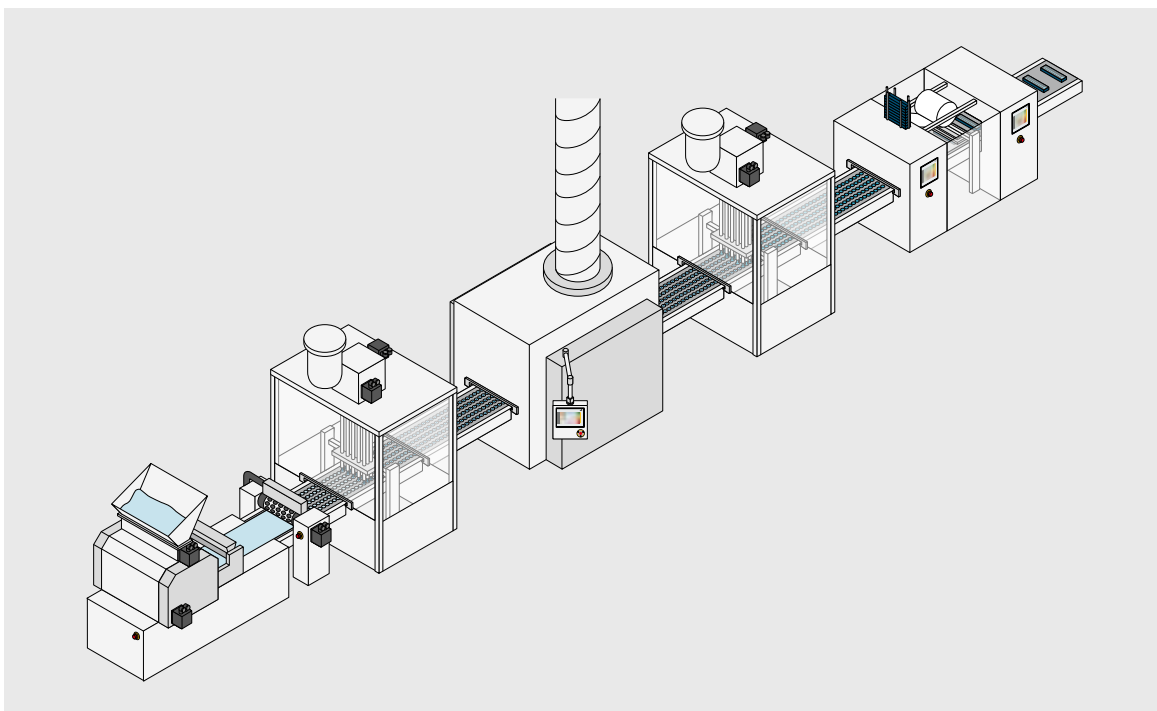

CE marking for individual machines and the overall plant

▶ 3.2 CE marking

3.2.3.7 Upgrading machinery

Essentially, the Machinery Directive describes the requirements for new machinery. However, if a machine is modified to such an extent that new

hazards are anticipated, an analysis will need to be carried out to determine whether the upgrade constitutes a significant modification. If this is the case, the measures to be taken will be the same as those for new machinery.

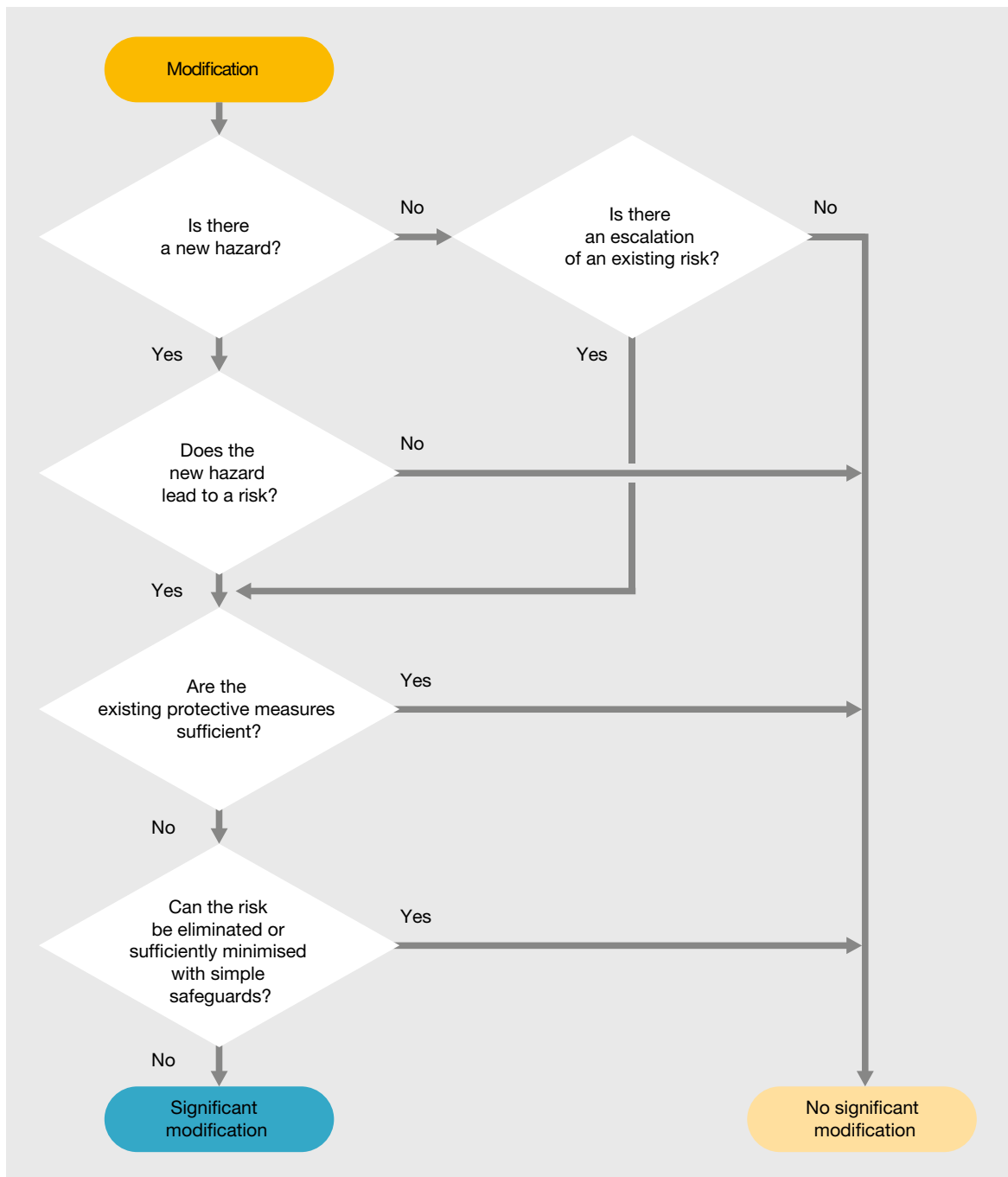

“Significant modifications to machinery” decision tree, source: Federal Ministry of Labour and Social Affairs

▶ 3.2 CE marking

3.2.3.8 Interlinked machinery

A system can no longer be regarded as a single machine if an event on one machine has a safety-related impact on another machine.

The fundamental principle applies: an interlinked plant must comply with the current legal status (particularly with regard to the Machinery Directive) and the conformity assessment procedure must be repeated for the entire plant.

Normally, the newly added machine and the interface between the new and existing machine must first undergo a risk assessment to work out the appropriate safety measures. On this basis a safety concept is developed, along with the safety design (specification of safety requirements) and the system integration. The process is completed with validation of the safety functions, to demonstrate that the safety measures that have been implemented meet all the requirements. And also with interlinked machinery, the process must end with the EC declaration of conformity for the whole system.

A particular challenge exists if existing machinery is to be linked to new machinery, which has been built with reference to different standards. In particular this is the case if a machine built to EN 954-1 is to be linked to another machine, which has been manufactured to 13849-1. EN 954-1 was valid until 31.12.2011. It included the integration of safety technology, but not the validation of components. The current standard EN ISO 13849-1 requires safety functions to be validated. In this case, the data for the safety functions for both machines is available in different forms, which makes it more difficult to validate the new, interlinked machine. With its extensive experience, Pilz can provide support in such cases. As an authorised representative, Pilz can perform the whole EC conformity assessment procedure for third parties, always taking current standards into account.

▶ 3.2 CE marking

3.2.3.9 Eight steps to a CE mark

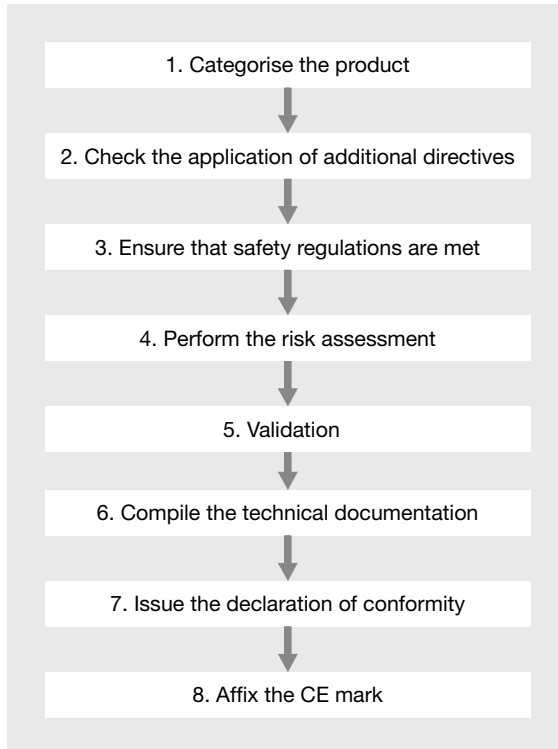

Step 1: Categorise the product

The CE marking process starts by categorising the product. The following questions need to be answered:

- ▶ Is the product subject to the Machinery Directive?

Here it's important to note that with Machinery Directive 2006/42/EC (in contrast to its predecessor), some products have been introduced (e.g. pressure vessels, steam boilers and funicular railways), while others have been omitted (e.g. electrical household and office equipment).

- ▶ Is the product listed in Annex IV of the Machinery Directive?

Annex IV of the Machinery Directive lists machinery that is considered “particularly hazardous”, such as presses, woodworking machinery, service lifts, etc. In this case, CE marking and the declaration of conformity must meet special requirements.

- ▶ Is the machine a subsystem or partly completed machinery?

Manufacturers issue an EC declaration of conformity for functional machines that meet the full scope of Annex I of the Machinery Directive. For subsystems, e.g. robots, which cannot yet meet the full scope of Annex I, the manufacturer issues a declaration of incorporation in accordance with Annex II B.

From the moment Machinery Directive 2006/42/EC becomes valid, all partly completed machinery must be accompanied by a declaration of incorporation in accordance with Annex II. At the same time, the manufacturer must perform a risk assessment and provide assembly instructions in accordance with Annex VI. Effectively the manufacturer's declaration or declaration of incorporation bans the subsystem from being put into service, as the machine is incomplete and as such may not be used on its own.

▶ 3.2 CE marking

▶ Is it a safety component?

Safety components are treated as machinery in accordance with Machinery Directive 2006/42/EC and will therefore be given a CE mark.

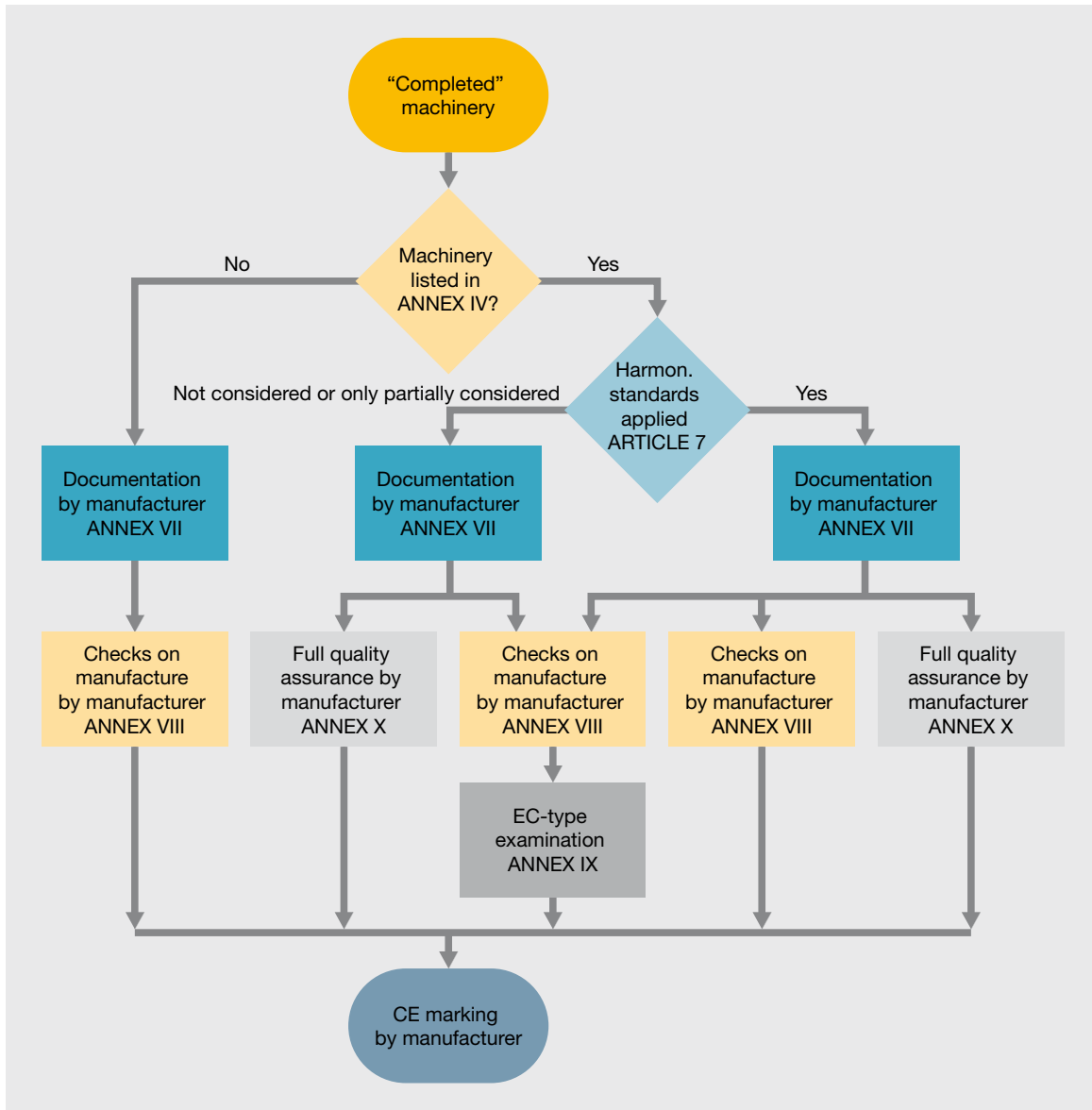

Potential assessment procedures in accordance with the new Machinery Directive

▶ 3.2 CE marking

Step 2: Check the application of additional directives

Where machinery is also subject to other EU directives, which cover different aspects but also provide for the affixing of the CE mark, the provisions of these directives must be met before the CE mark is applied. If the machine contains electrical equipment, for example, it will often be subject to the Low Voltage Directive and, possibly, the EMC Directive too.

Step 3: Ensure that safety regulations are met

It is the responsibility of the machine manufacturer to comply with the essential health and safety requirements in accordance with Annex I of the Machinery Directive. The formulation of these requirements is relatively abstract, but specifics are provided through the EU standards.

The EU publishes lists of directives and the related harmonised standards. Application of these standards is voluntary, but compliance does provide presumption of conformity with the regulations. This can substantially reduce the amount of evidence required, and a lot less work is needed to incorporate the risk assessment.

▶ 3.2 CE marking

Step 4: Perform the risk assessment

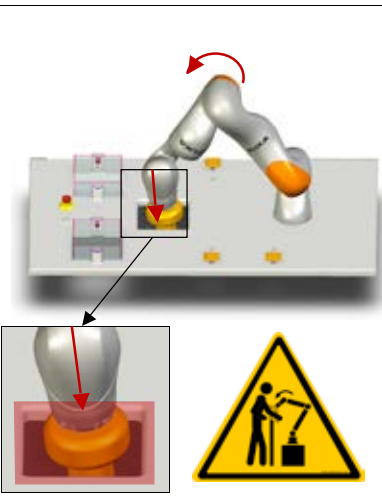

Pilz GmbH & Co. KG

Hazard Identification		Hazard No:	2.14
Title	Hazards generated by quasi-static contact between the robot and parts of the system		
Location	Robot, robot area (working range of the robot)		
Impact of hazard	Finger, Hand ND		
Life phase	Normal operation, setup, maintenance, servicing and repair		
Activity	Automatic mode, semiautomatic mode, tooling/adjusting, programming/testing, eliminating disruptions in the workflow, monitoring production processes, troubleshooting and fault rectification, cleaning/maintenance, repair		
Explanation of activity	n/a		
Type of hazard	Mechanical hazard		
Origin or consequences	Shearing, crushing		
Description	During operation and the associated movements of the robot arm there is a danger of limbs being crushed or severed between the robot arm and fixed parts of the system.		
Risk estimation and risk evaluation			
Degree of possible harm:	11	Possibility of avoidance:	2.5
Probability of occurrence of a dangerous event:	2.5	Frequency of exposure:	5
Pilz Hazard Rating (PHR):	343	Risk level:	High risk
Risk reduction concept		Reference	
<u>Risk reduction 1: Design safeguards:</u> System parts must be designed in such a way according to EN 349 that they cannot form any hazardous crush or shear points with the robot. Any remaining crush points must be designed in accordance with ISO TS 15066.		EN ISO 12100 EN ISO 13849-1 EN 349 EN ISO 10218-2 EN ISO 13857 EN ISO 13850 ISO TS 15066	
<u>Risk reduction 2: Technical safeguards:</u> Optimisation of the robot path in order to avoid crush and shear points. The following measures must be taken using safety proven software in accordance with TS 15066: - Reduction in velocity - Reduction in force			

Risk Assessment: Robot Manufacturing Application/Trade Fair 1

Extract from a risk assessment by Pilz GmbH & Co. KG

▶ 3.2 CE marking

The manufacturer is obliged to carry out a risk assessment to determine all the hazards associated with his machine. The result of this assessment must then be considered in the design and construction of that machine. The contents and scope of a risk assessment are not specified in any directive, but EN ISO 12100 describes the general procedure.

All relevant hazards must be identified, based on the intended use – taking into consideration all the lifecycles once the machine is first made available on the market. All the various groups who come into contact with the machine, such as operating, cleaning or maintenance staff for example, are also considered.

The risk is assessed and evaluated for each hazard. Risk-reducing measures are established in accordance with the state of the art and in compliance with the standards. The residual risk is assessed at the same time: if the residual risk resulting from a danger point cannot be reduced to an acceptable level, additional measures are required. This iterative process is continued until the necessary safety is achieved.

Step 5: Validation

Validation is one of the key steps in the conformity assessment procedure. Essentially it proves that a machine complies with safety regulations. All information about validation is available in Chapter 3.6.

Step 6: Compile the technical documentation

In accordance with the Machinery Directive, technical documentation specifically comprises:

- ▶ An overall drawing of the machinery and drawings of the control circuits
- ▶ Full, detailed drawings (accompanied by any calculation notes, test results, etc. required to check the conformity of the machinery with the essential health and safety requirements)
- ▶ A list of the essential requirements of this directive, standards and other technical specifications used in the design of the machinery, a description of the protective measures implemented to eliminate hazards presented by the machinery (generally covered by the risk analysis)
- ▶ Technical reports or certificates; reports or test results showing conformity
- ▶ The machine's operating instructions
- ▶ A general machine description
- ▶ Declaration of conformity or declaration of incorporation plus the assembly instructions
- ▶ Declarations of conformity for the machines or devices incorporated into the machinery

This documentation does not have to be permanently available in material form. However, it must be possible to assemble it and make it available within a period of time commensurate with its importance. It must be retained for at least ten years following the date of manufacture and be available to present to the relevant national authorities. In the case of series manufacture, that period shall start on the date that the last machine is produced.

▶ 3.2 CE marking

Step 7: Issue the EC declaration of conformity

By issuing the EC declaration of conformity, the manufacturer declares that they have considered all the directives that apply for the product. The person signing an EC declaration of conformity must be authorised to represent his company. This means that the signatory is legally entitled to execute a legal transaction, such as signing the EC declaration of conformity, on account of their job function.

When an authorised employee of the company adds their valid signature to an EC declaration of conformity, they trigger the liability of the natural responsible person and, if applicable, the company as a legal entity.

The declaration may also be signed by an authorised representative.

The Machinery Directive requires the declaration to name the person authorised to compile the technical documentation. This person must be established in the EU.

Step 8: Affix the CE marking

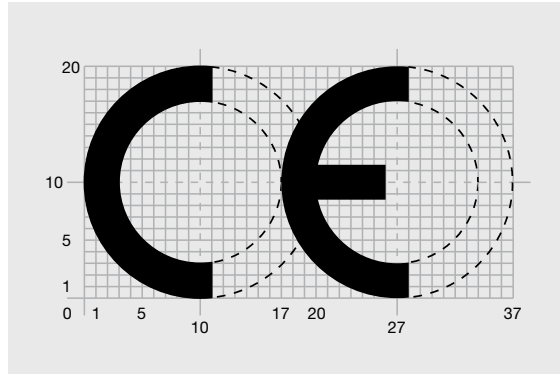

CE mark characteristics

The CE mark may be affixed once the EC declaration of conformity has been issued.

It's important that CE marking for the complete machine is clearly distinguishable from any other CE markings, e.g. on components. To avoid confusion with any other markings, it is advisable to affix the CE marking for the complete machine to the machine type plate, which must also contain the name and address of the manufacturer.

▶ 3.3 Directives

Of the almost 30 active directives now available, only a small selection is relevant to the typical machine builder. Some directives may have a very long or bureaucratic title in addition to the directive number (e.g. 2006/42/EC). Variations can be seen in the last part of the directive number. This will contain EC, EU, EG, EWG or some other abbreviation, depending on the language area and issue

date. As a result it is generally very difficult to name the directive. These long titles are often abbreviated separately, even though this can also lead to misunderstandings. Here is a list of some of the key directives with both their official title and their usual, though unofficial, abbreviated title:

Directive	Abbreviated title (unofficial)	Official title
2006/42/EC	Machinery Directive	Directive 2006/42/EC of the European Parliament and of the Council of 17 May 2006 on machinery, and amending Directive 95/16/EC (recast)
2001/95/EC	Product Safety Directive	Directive 2001/95/EC of the European Parliament and of the Council of 3 December 2001 on general product safety
2014/30/EU	EMC Directive	Directive 2014/30/EU of the European Parliament and of the Council of 26 February 2014 on the harmonisation of the laws of the Member States relating to electromagnetic compatibility (recast)
2014/53/EU	Radio Equipment Directive	Directive 2014/53/EU of the European Parliament and of the Council of 16 April 2014 on the harmonisation of the laws of the Member States relating to the making available on the market of radio equipment and repealing Directive 1999/5/EEC
2003/10/EC	Noise Directive	Directive 2003/10/EC of the European Parliament and of the Council of 6 February 2003 on the minimum health and safety requirements regarding the exposure of workers to the risks arising from physical agents (noise)
2014/35/EU	Low Voltage Directive	Directive 2014/35/EU of the European Parliament and of the Council of 26 February 2014 on the harmonisation of the laws of the Member States relating to the making available on the market of electrical equipment designed for use within certain voltage limits
Regulation (EU) 2016/425	PPE Directive	Regulation (EU) 2016/425 of the European Parliament and of the Council of 9 March 2016 on personal protective equipment and repealing Council Directive 89/686/EC (89/686/EEC applicable with a transition period until 20. April 2019)

The aim of the directives is to guarantee the free movement of goods within the EU. The full texts of the directives are available online. Of all these directives, only the Machinery Directive will be examined here in any further detail. However, the list of relevant standards will naturally refer to standards that relate to other directives.

▶ 3.3 Directives

3.3.1 Machinery Directive

2006/42/EC has special significance in terms of the functional safety of machinery. This directive, generally known as the “Machinery Directive”, is concerned with the standardisation of European safety requirements on machinery.

3.3.1.1 Contents

The Machinery Directive covers the key aspects of machine safety. The contents of the Machinery Directive are as follows:

- ▶ Scope, placing on the market, freedom of movement
- ▶ Conformity assessment procedures
- ▶ CE marking
- ▶ Essential health and safety requirements
- ▶ Categories of machinery and the applicable conformity assessment procedures
- ▶ EC declaration of conformity and type-examination
- ▶ Requirements of notified bodies

3.3.1.2 Validity

The Machinery Directive 2006/42/EC replaced the previous version 98/37/EC with effect from 29.12.2009. There was no transition period.

3.3.1.3 Standards relating to the Machinery Directive

At this point, it makes no sense to name all the standards that are listed under the Machinery Directive and are therefore considered as harmonised. As of Winter 2016, there were more than 750 standards listed directly. To then add all the standards that are relevant indirectly via the standards that are listed directly would go far beyond the scope of this compendium. The following chapters will therefore concentrate on those standards for the Machinery Directive which are of general significance.

▶ 3.4 Standards

3.4.1 Publishers and scope

At European level, harmonisation of the legislation also triggered harmonisation of the standards. Traditionally, almost every country has one or more of its own standards institutes. There are also some international cooperative organisations. This means that the same standard is published at different levels under different names. In most if not all cases, the generic name of the standard is continued and recognisable as part of the national standard name. More about that below.

3.4.1.1 International standards

At international level, the most important publishers of engineering standards are probably the International Electrotechnical Commission (IEC) and the International Organization for Standardization (ISO), both of which are based in Geneva. While the IEC is primarily concerned with electrical and electronic issues, ISO deals mainly with mechanical issues. Well over 100 countries are currently members of the two organisations, which gives considerable weight to those standards developed by IEC and ISO.

The EN standards are applied at European level. EN standards are normally developed through CEN and CENELEC as an EU initiative. As with IEC and ISO, CEN and CENELEC divide up the standards. CENELEC is responsible for electrical issues.

Today, many standards are developed almost in a package as an IEC or ISO standard in co-operation with the EU via CEN and CENELEC. EN IEC or EN ISO standards are the result of these efforts.

3.4.1.2 National standards

The diversity of national standards and standards institutes within all of Europe is almost unmanageable. In the EU at least, the aim is to produce the majority of standards directly as an EN standard, which is then reflected at national level, i.e. the EN standard is declared a national standard or the national standard is introduced as an EN standard.

In Germany for example, the German Institute for Standardization (Deutsches Institut für Normung - DIN) is responsible for publishing national standards. Today it's common practice for DIN standards to be developed directly in conjunction with CEN or CENELEC as DIN EN ISO or DIN EN. The only difference between these standards is usually the national preface to the EN, ISO or IEC standard.

The same standard will come into effect at EU level as an EN ISO or EN IEC standard, while the identical German standard is called DIN EN ISO or DIN EN. In other European countries, the procedure is virtually the same except that a different institute publishes the standard. In Austria, this would be the Austrian Standards Institute (Österreichisches Normungsinstitut - ÖNorm), while Great Britain has the British Standards Institute (BSI).

If an ISO standard becomes an EN standard, its title will be EN ISO. If it then becomes a DIN standard, its full title will be DIN EN ISO. The more local the institute, the further forward it appears in the name. One curious aside: if an IEC standard becomes an EN standard, the IEC name is dropped. IEC 61508 becomes the European standard EN IEC 61508 or the German DIN EN IEC 61508.

While many countries such as China or Switzerland, for example, also follow the European procedure for a centralised standards institute, there are still some nasty surprises to be had elsewhere. In the USA, standards are published by ANSI, OSHA, RSA and UL, among others.

▶ 3.4 Standards

3.4.2 EN engineering safety standards

There is no intention at this point to provide a complete list of the European engineering safety standards. Over 760 standards are listed as

harmonised under the Machinery Directive alone. The following section addresses a selection of the general safety standards. They are explained in various degrees of detail, depending on the significance of the individual standard.

Standard	Harmonised	Title
EN 349:2008	Yes	Safety of machinery Minimum gaps to avoid crushing of parts of the human body
EN 547-1 to -3:2008	Yes	Safety of machinery Human body measurements
EN 574:2008	Yes	Safety of machinery Two-hand control devices – Functional aspects Principles for design
DIN EN ISO 14120:2016 replaces EN 953:2009	Yes	Safety of machinery Guards – General requirements for the design and construction of fixed and movable guards
EN 1005-1 to -4:2008 EN 1005-5:2007	Yes No	Safety of machinery Human physical performance
EN 1037:2008 Identical to ISO 14118:2000	Yes	Safety of machinery Prevention of unexpected start-up
EN ISO 14119 (Replaces EN 1088:2008 and ISO 14119:2006)	Yes	Safety of machinery Interlocking devices associated with guards. Principles for design and selection
DIN EN ISO 11161:2010	Yes	Safety of machinery Integrated manufacturing systems – Basic requirements
EN ISO 12100:2010 Replaces EN ISO 12100-1 and 2; EN ISO 14121; EN 292	Yes	Safety of machinery General principles for design – Risk assessment and risk reduction
EN 12453:2000	No	Industrial, commercial and garage doors and gates Safety in use of power operated doors – Requirements
EN ISO 13849-1:2015 replaces EN ISO 13849-1:2009	Yes	Safety of machinery Safety-related parts of control systems – Part 1: General principles for design
EN ISO 13849-2:2012	Yes	Safety of machinery Safety-related parts of control systems – Part 2: Validation
EN ISO 13855:2010	Yes	Safety of machinery Positioning of safeguards with respect to the approach speeds of parts of the human body
EN ISO 13857:2008	Yes	Safety of machinery Safety distances to prevent hazard zones being reached by upper and lower limbs

▶ 3.4 Standards

Standard	Harmonised	Title
ISO/TR 23849:2010 identical to IEC/TR 62061-1:2009	No	Guidance on the application of ISO 13849-1 and IEC 62061 in the design of safety-related control systems for machinery
EN 60204-1:2010	Yes	Safety of machinery Electrical equipment of machines - Part 1: General requirements
EN 60947-5-1:2009 EN 60947-5-2:2012 EN 60947-5-3:2005 EN 60947-5-4:2003 EN 60947-5-5:2013 EN 60947-5-6:2001 EN 60947-5-7:2003 EN 60947-5-8:2006 EN 60947-5-9:2007	Yes	Low-voltage switchgear and controlgear Part 5: Control circuit devices and switching elements
EN 61326-3 Parts 1+2:2008	No	Electrical equipment for measurement, control and laboratory use – EMC requirements
EN 61496-1:2010	Yes	Safety of machinery Electrosensitive protective equipment – Part 1: General requirements and tests
IEC 61496-2:2013 CLC/TS 61496-2:2006	No	Safety of machinery Electrosensitive protective equipment – Part 2: Particular requirements for equipment using active optoelectronic protective devices (AOPDs)
CLC/TS 61496-3:2008 Replaces EN 61496-3:2003	No	Safety of machinery Electrosensitive protective equipment – Part 3: Particular requirements for active optoelectronic protective devices responsive to diffuse reflection (AOPDDR)
EN 61508 Parts 1-7:2010	No	Functional safety of safety-related electrical, electronic and programmable electronic control systems
EN 61511 Parts 1-3:2004	No	Functional safety – Safety instrumented systems for the process industry sector
EN 61784-3:2010	No	Industrial communication networks – Profiles – Part 3: Functional safety fieldbuses – General rules and profile definitions
EN 61800-5-2:2007	Yes	Adjustable speed electrical power drive systems – Part 5-2: Safety requirements – Functional
IEC/TS 62046:2008	No	Safety of machinery Application of protective equipment to detect the presence of persons
EN 62061:2016	Yes	Safety of machinery Functional safety of safety-related electrical, electronic and programmable electronic control systems
IEC/TR 62685:2010	No	Industrial communication networks – Profiles – Assessment guideline for safety devices using IEC 61784-3 functional safe communication profiles (FSCPs)
NFPA 79:2013	No	Industrial machinery

▶ 3.4 Standards

3.4.3 Generic standards and design specifications

3.4.3.1 EN ISO 12100 and EN ISO 14121

Standard	Harmonised	Title
EN ISO 12100:2010 Replaces EN ISO 12100-1 and -2; EN ISO 14121-1	Yes	Safety of machinery General principles for design – Risk assessment and risk reduction

In 2010, EN ISO 12100 provided a further summary of EN 12100-1 and -2 plus EN 14121-1. This standard is identical in content to the named standards and simply summarises them within one document.

The diagram overleaf (see page 3-22) identifies the individual elements examined in this standard. The standard provides a good selection of the hazards, risk factors and design principles that need to be considered.

Elements within the diagram that have a dark yellow background are the areas covered by the user standards EN ISO 13849-1 and EN/IEC 62061 and are examined there in greater detail. Where possible the diagram refers to the corresponding sections dealing with the relevant aspect within the standards. Some points can certainly be found in several standards, but the level of detail generally varies.



3.4 Standards

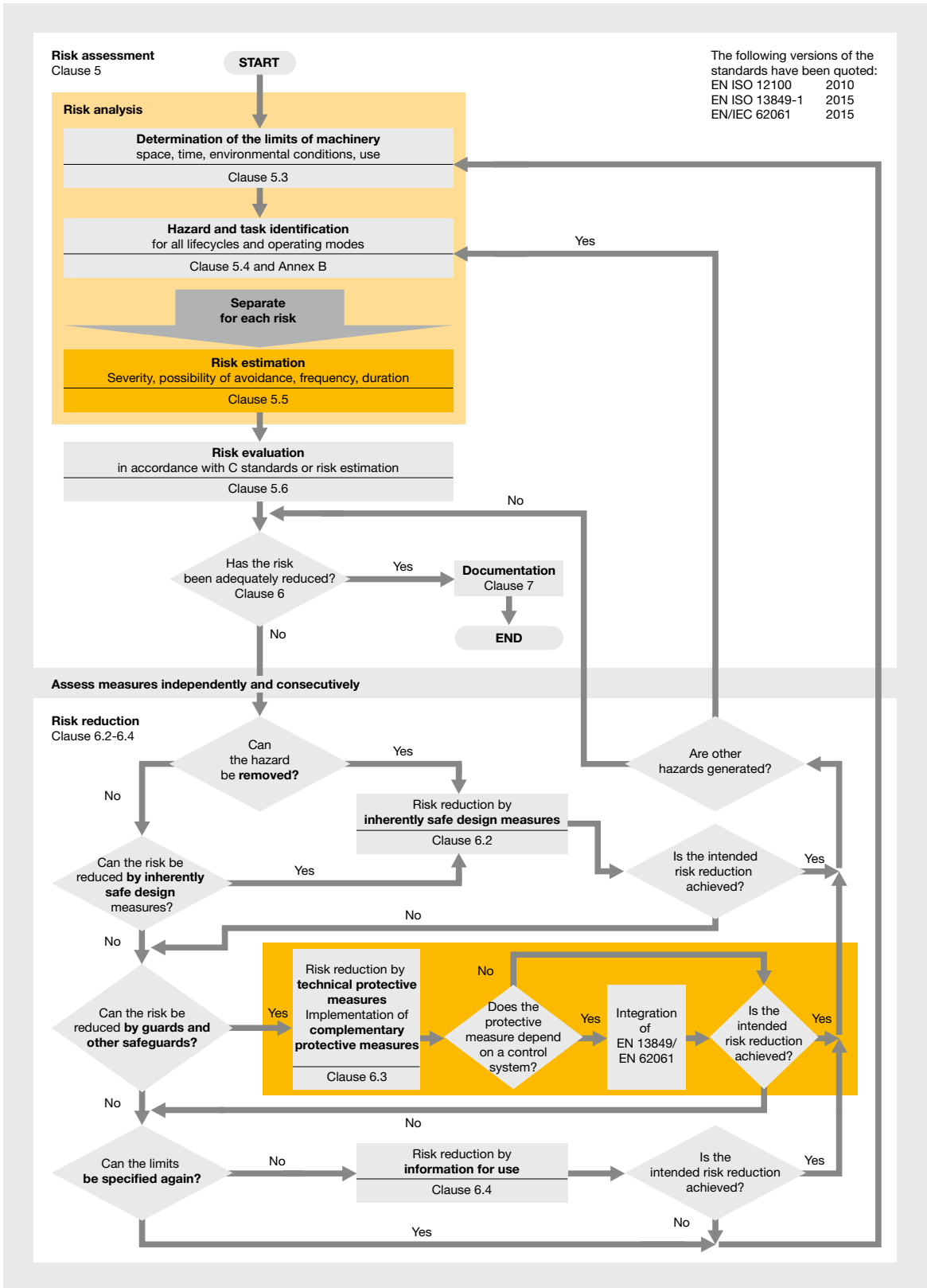

Risk assessment and risk reduction in accordance with EN ISO 12100

▶ 3.4 Standards

3.4.3.2 IEC/TR 62685 Test requirements and EMC

Standard	Harmonised	Title
IEC/TR 62685:2010	No	Industrial communication networks – Profiles – Assessment guideline for safety devices using IEC 61784-3 functional safety communication profiles (FSCPs)

IEC/TR 62685 was produced from the test requirements of the German BGIA document GS-ET-26 and covers the requirements of safety components within a safety function. It covers the issue of labelling and EMC as well as mechanical and climatic tests. This closes some of the gaps left by EN ISO 13849-1 and EN 61784-3. Overall the

document is more relevant to safety component manufacturers than plant and machine builders. However, as the document contains a good comparison of EMC requirements, it may also be of interest to machine builders.

3.4.3.3 EN 61784-3 Safe fieldbuses

Standard	Harmonised	Title
EN 61784-3:2010	No	Industrial communication networks – Profiles – Part 3: Functional safety fieldbuses – General rules and profile definitions

The EN 61784-3 series of standards covers a whole range of safety enhancements for different fieldbus profiles, based on the specifications of EN 61508. These enhancements are handled as security profiles and describe the mechanisms and technical details of these profiles. For the average machine builder, at most the generic part of EN 61784-3 will be of interest, as this is the part that describes the general safety principles. The profile documents EN 61784-3-x are mainly intended for device manufacturers who wish to build their own safety

devices in accordance with one of the published profiles. In this case, it makes sense to work in cooperation with the relevant user groups behind these profiles and to be familiar with the basic profiles described in the series EN 61784-1 and -2, as well as EN 61158. A complete profile consisting of the relevant parts of EN 61784 and EN 61158 will contain between 500 and 2,000 pages. All the profiles together amount to around 10,000 pages.

▶ 3.4 Standards

3.4.3.4 EN ISO 13849-1

Standard	Harmonised	Title
EN ISO 13849-1:2015	Yes	Safety of machinery Safety-related parts of control systems – Part 1: General principles for design
EN ISO 13849-2:2012	Yes	Safety of machinery Safety-related parts of control systems – Part 2: Validation

Contents

EN ISO 13849-1 addresses the issue of assignment of suitable reliability classes for risks using a risk graph and also deals with the assessment of safety functions based on structural and statistical methods. The objective is to establish the suitability of safety measures to reduce risks. EN ISO 13849-2 describes the validation aspect pertinent to EN ISO 13849-1. So together, both standards are practically equal (but not identical) to EN 62061.

The work involved in making the calculations required under this standard can be reduced considerably if appropriate software is used. Calculation tools such as the Safety Calculator PAScal are available as free software:
<https://www.pilz.com/de-INT/eshop/00105002187038/PAScal-Safety-Calculator>,
 webcode: web150431



PAScal Safety Calculator

Scope

EN ISO 13849-1 is a generic standard for functional safety. It has been adopted at ISO level and within the EU is harmonised to the Machinery Directive. It therefore provides presumption of conformity within the EU. The scope is given as the electrical, electronic, programmable electronic, mechanical, pneumatic and hydraulic safety of machinery.

Risk assessment/risk analysis

Risks are assessed in EN ISO 13849-1 with the aid of a graph. The assessed criteria include severity of injury, frequency of exposure to the risk and the possibility of avoiding the risk. The outcome of the assessment is a required performance level (PL_r) for the individual safety functions intended to minimise the risks.

In subsequent stages of the risk assessment, the levels determined using the graph are aligned with the selected risk reduction measures. For each classified risk, one or more measures must be applied to prevent the risk from occurring or to sufficiently reduce the risk. The quality of the measure, expressed as the performance level, must at least correspond to the level determined for the respective risk.

▶ 3.4 Standards

Determination of the required performance level PL_r

Just three parameters need to be examined to assess the performance level (PL):

Severity of injury	S
Slight (normally reversible injury)	S_1
Serious (normally irreversible injury including death)	S_2

Frequency and/or duration of exposure to a hazard	F
Seldom to less often and/or exposure time is short	F_1
Frequent to continuous and/or the exposure time is long	F_2

Possibility of avoiding the hazard	P
Possible under specific conditions	P_1
Scarcely possible	P_2

The required performance level PL_r is calculated using the following graph and the classification of the individual parameters. Assessment of the risk begins at the starting point on the graph and then follows the corresponding path, depending on the risk classification. The required performance level PL_r , a, b, c, d or e is determined once all the parameters have been assessed.

A new addition in the latest version of the standard is the option of assessing the probability of occurrence of a hazard. With the conclusion that this probability is too low, the previously determined PL_r can be reduced by one level. The devil is in the details in this case: namely, that comparable machinery should be used to assess this question. This comparable machinery is equipped with sufficient safety measures, however, as otherwise it would not be available on the market. A low occurrence of accidents on comparable machines is thus not sufficient justification for classifying the associated hazards as low. Instead this would prove that the implemented safety measures were appropriate (and a reduction of these would be misguided).

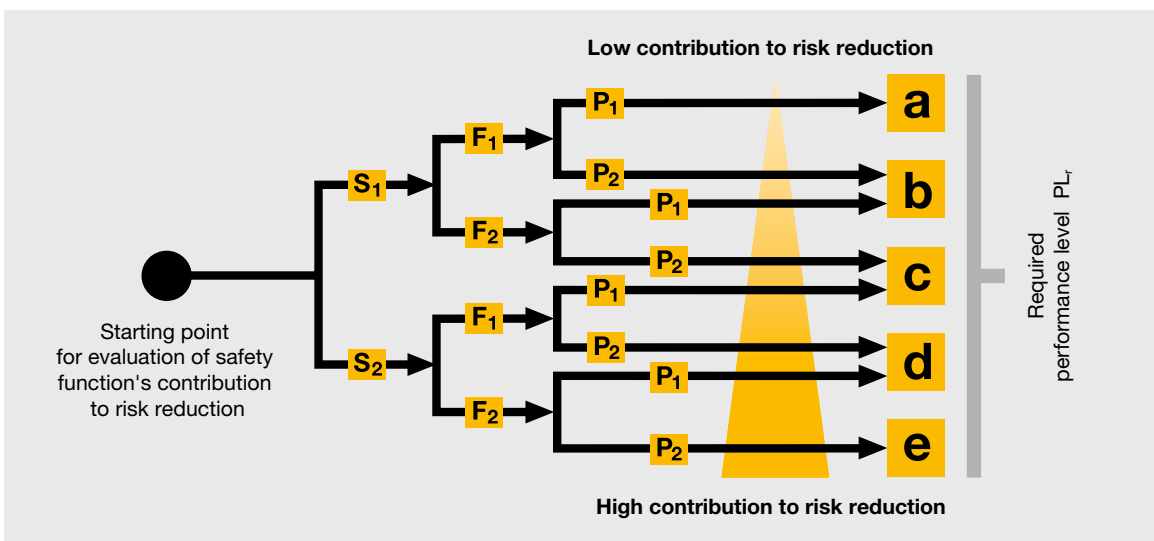

Risk graph in accordance with EN ISO 13849-1

▶ 3.4 Standards

Assessing the implementation/examining the system

EN ISO 13849-1 works on the assumption that there is no such thing as a safe device. Devices only become suitable through an appropriate design for use in applications with increased requirements. As part of an assessment each device is given a PL (performance level), which describes its suitability. Simple components can also be described via their $MTTF_d$ (mean time to dangerous failure) or $B10_d$ value (mean number of cycles until 10 % of the components fail dangerously).

The following considerations examine how the failure of devices or their components affects the safety of the system, how likely these failures are to occur and how to calculate the PL.

Determination of common cause failure – CCF factor

The assessment of measures against common cause failures comprises several individual factors. Structural aspects such as separation of the channels as well as organisational aspects such as training of the designers have an effect here. An evaluation scale is used, on which a score of between 0 and 100 % can be achieved.

Requirement	Score
Physical separation of safety circuits and other circuits	15 %
Diversity (use of different technologies)	20 %
Design/application/experience	20 %
Assessment/analysis	5 %
Competence/training	5 %
Environmental influences (EMC, temperature, ...)	35 %

With EN ISO 13849-1, the effect of the CCF is deemed acceptable if the total score achieved is ≥ 65 %.

PL assessment

IEC ISO 13849-1 uses the diagnostic coverage (DC), system category and the system's $MTTF_d$ to determine the PL. The DC depends on λ_{DD} (failure rate of detected dangerous failures) and λ_{Dtotal} (failure rate of total dangerous failures).

In the simplest case this is expressed as:

$$DC = \frac{\sum \lambda_{DD}}{\sum \lambda_{Dtotal}}$$

On complex systems, an average DC_{avg} is calculated:

$$DC_{avg} = \frac{\frac{DC_1}{MTTF_{d1}} + \frac{DC_2}{MTTF_{d2}} + \dots + \frac{DC_N}{MTTF_{dN}}}{\frac{1}{MTTF_{d1}} + \frac{1}{MTTF_{d2}} + \dots + \frac{1}{MTTF_{dN}}}$$

The DC value is assigned a size range:

Diagnostic coverage	Range of DC
None	$DC < 60$ %
Low	$60 \% \leq DC < 90$ %
Medium	$90 \% \leq DC < 99$ %
High	$99 \% \leq DC$

With homogeneous or single-channel systems, the $MTTF_d$ value can be established approximately as the sum of the reciprocal values of the individual components, corresponding to the $MTTF_d$ value of a single channel:

$$\frac{1}{MTTF_d} = \sum_{i=1}^N \frac{1}{MTTF_{d,i}}$$

▶ 3.4 Standards

With dual-channel, diverse systems, the $MTTF_d$ value of both channels needs to be calculated separately. Both values are included in the calculation of the combined $MTTF_d$, using the formula below.

$$MTTF_d = \frac{2}{3} \left[MTTF_{d,C_1} + MTTF_{d,C_2} - \frac{1}{\frac{1}{MTTF_{d,C_1}} + \frac{1}{MTTF_{d,C_2}}} \right]$$

Here too, a table is used to derive a qualitative evaluation from the numeric value, which is then used in subsequent considerations.

MTTF _d assessment	MTTF _d
Low	3 years ≤ MTTF _d < 10 years
Medium	10 years ≤ MTTF _d < 30 years
High	30 years ≤ MTTF _d < 100 years

The system architecture can be divided into five different categories. The achieved category depends not only on the architecture, but on the components used and diagnostic coverages. Note that the safety functions are broken down into parts so that the failure of one part would render the entire safety function non-functional

(often called a subsystem). Each of these subsystems can have its own category.

In a final assessment stage, a graphic is used to assign the PL based on the recently calculated values.

The most practical approach is to select the column for Category and DC first. Then choose the relevant $MTTF_d$ range from the bar. The PL result can now be read from the left-hand scale. In most cases, some interpretation will still be required, as often there is no clear relationship between the $MTTF_d$ range and the PL.

In category 4, larger $MTTF_d$ values (and therefore smaller probability of dangerous failures per hour - PFH_d values) can also be used than shown in the graphic. Annex K of the standard DIN EN ISO 13849-1 must be applied here.

The final step is to compare the required PL_r level from the risk assessment with the achieved PL. If the achieved PL is greater than or equal to the required PL_r , the requirement for the implementation is considered to have been met.

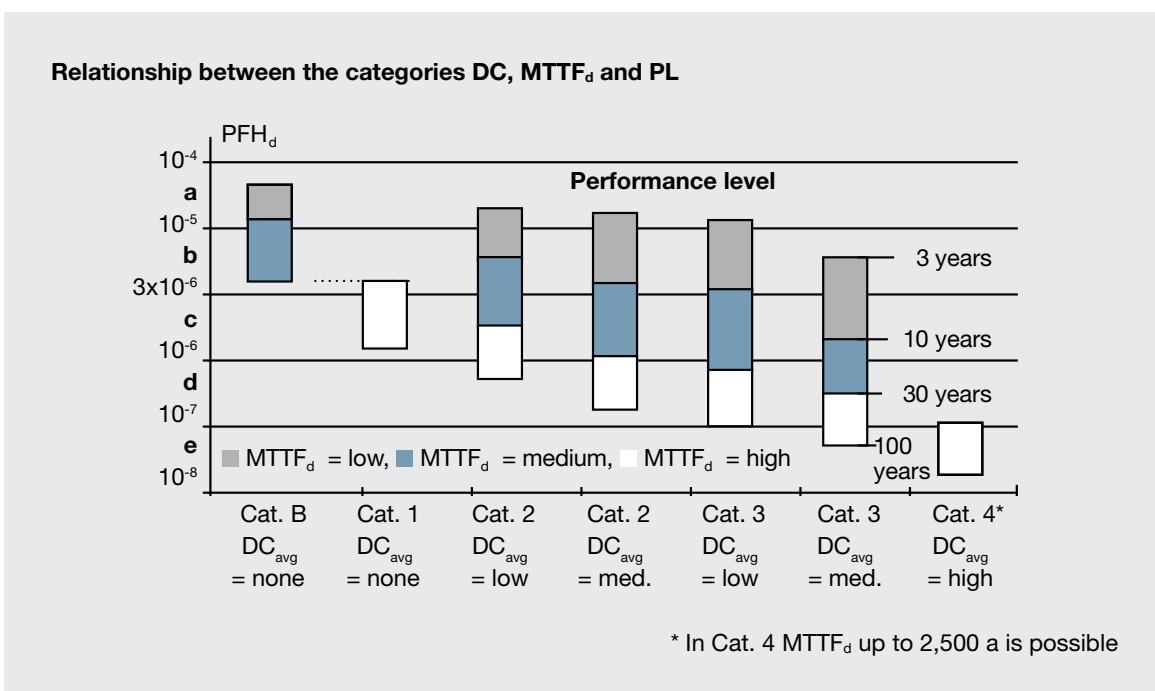

Graph to determine the PL in accordance with EN ISO 13849-1

▶ 3.4 Standards

3.4.3.5 EN ISO 13855

Standard	Harmonised	Title
EN ISO 13855:2010 Replaces EN 999	Yes	Safety of machinery Positioning of safeguards with respect to the approach speeds of parts of the human body

EN ISO 13855 primarily defines human approach speeds. These approach speeds need to be considered when designing safety measures and selecting the appropriate sensor technology. Different speeds and sizes are defined, depending on the direction and type of approach. Even an indirect approach is considered.

The problem regarding measurement of the overall stopping performance is considered alongside the measurement of safety distances. Clear specifications are provided as to how the overall stopping performance should and should not be measured.

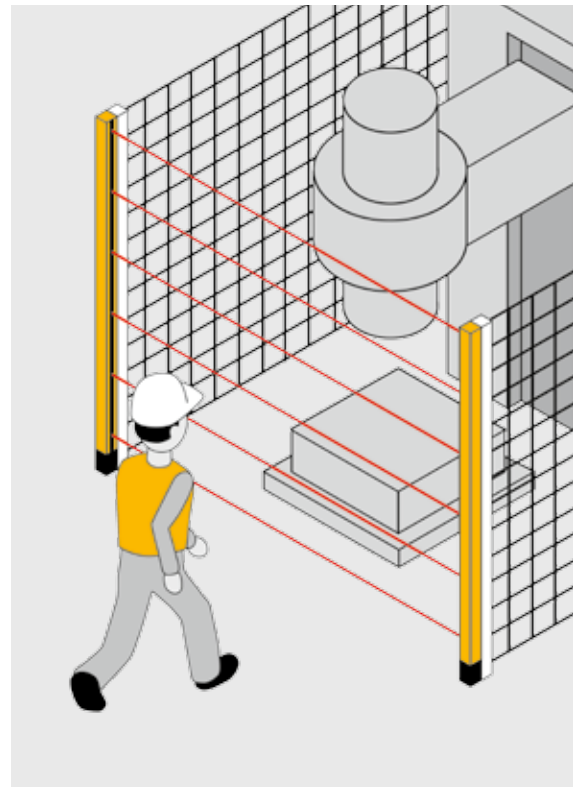

Safeguards prevent operators from approaching hazardous movements.

3.4.3.6 EN ISO 13857

Standard	Harmonised	Title
EN ISO 13857:2008	Yes	Safety of machinery Safety distances to prevent hazard zones being reached by upper and lower limbs

EN ISO 13857 was first published in 2008 and examines the safety distances required to prevent hazard zones being reached by the upper and lower limbs. It is worth stressing that this standard makes it clear that different anthropometric data (size, length of limbs...) may apply for other populations or groups (e.g. Asian countries,

Scandinavia, children) and that this could give rise to other risks. Application of this standard may therefore be restricted, particularly in the public domain or when exporting to other countries.

▶ 3.4 Standards

3.4.3.7 EN 61511 Safety instrumented systems for the process industry sector

Standard	Harmonised	Title
EN 61511 Parts 1-3:2004	No	Functional safety – Safety instrumented systems for the process industry sector

The EN 61511 series of standards covers safety issues concerning plants and systems in the process industry. As a sector standard of EN 61508, the EN 61511 series is a sister standard of EN 62061. This is reflected in the similar observations and mathematical principles contained in the three standards. However, an important difference for most end users, as well as component manufacturers, is the differentiation between the demand modes. High demand modes have always been assumed in engineering, but EN 61511 also

recognises a low demand mode. The key characteristic for this mode is that a safety function is demanded (operated) less than once per year. As a result, EN 61511 introduced a PFD (Probability of failure on low demand) alongside the PFH (Probability of failure on high demand) and SILcl (maximum achievable Safety Integrity Level). It is particularly worth noting that the SILcl for low demand mode may vary from the SILcl for high demand mode.

3.4.3.8 EN 62061

Standard	Harmonised	Title
EN 62061:2016	Yes	Safety of machinery Functional safety of safety-related electrical, electronic and programmable electronic control systems

Contents

EN 62061 addresses the issue of risk assessment using a risk graph, which in this case is in the form of a table. It also deals with the validation of safety functions based on structural and statistical methods. As with EN ISO 13849-1, the objective is to establish the suitability of safety measures to reduce risks.

As with EN 13849-1, there is considerable work involved in making the calculations required under this standard. This can be reduced considerably if appropriate software is used, such as the Safety Calculator PAScal.
<https://www.pilz.com/de-INT/eshop/00105002187038/PAScal-Safety-Calculator>,
webcode: web150431

Scope

EN IEC 62061 is one of the generic standards for functional safety. It has been adopted at IEC level and in the EU is harmonised as a standard within the Machinery Directive. It therefore provides presumption of conformity within the EU. The scope is given as the electrical, electronic and programmable electronic safety of machinery. It is not intended for mechanical, pneumatic or hydraulic energy sources. The application of EN ISO 13849-1 is advisable in these cases.

▶ 3.4 Standards

Risk assessment/risk analysis

Risks are assessed in IEC 62061 using tables and risk graphs. The evaluations made for each individual risk include the severity of potential injuries, the frequency and duration of exposure, the possibility of avoidance of a risk and the probability of occurrence of the risk. The outcome of the assessment is the required safety integrity level (SIL) for the individual risks.

In subsequent stages of the risk assessment, the levels determined using the risk graph are aligned with the selected risk reduction measures. For each classified risk, one or more measures must be applied to prevent the risk from occurring or to sufficiently reduce the risk. The SIL for that measure must at least correspond to the required SIL, determined on the basis of the risk.

Determination of the required SIL

According to EN IEC 62061 there are four different parameters to assess. Each parameter is awarded points in accordance with the scores in the following tables.

SIL classification, based on the above entries, is made using the table below, in which the consequences are compared with the Class CI. Class CI is the sum total of the scores for frequency, duration, probability and avoidance. Areas marked with OM indicate that the standard recommends the use of other measures in this case.

Frequency and duration of exposure	Fr < 10 min	Fr ≤ 10 min	Probability of occurrence	Pr	Avoidance	Av
≤ 1 hour	5	5	Very high	5		
> 1 hour – ≤ 1 day	5	4	Likely	4		
> 1 day – ≤ 2 weeks	4	3	Possible	3	Impossible	5
> 2 weeks – ≤ 1 year	3	2	Rarely	2	Rarely	3
> 1 year	2	1	Negligible	1	Probable	1

Consequences	S	Class CI = Fr+Pr+Av				
		3-4	5-7	8-10	11-13	14-15
Death, losing an eye or arm	4	SIL 2	SIL 2	SIL 2	SIL 3	SIL 3
Permanent, losing fingers	3		OM	SIL 1	SIL 2	SIL 3
Reversible, medical attention	2			OM	SIL 1	SIL 2
Reversible, first aid	1				OM	SIL 1

OM = other measures recommended

Risk graph in accordance with EN IEC 62061

▶ 3.4 Standards

Assessing the implementation/examining the system

The principle assumption is that there is no such thing as a safe device. Devices only become suitable through an appropriate design for use in applications with increased requirements. As part of an assessment each device is given a SIL, which describes its suitability. Simple components can also be described via their $MTTF_d$ or $B10_d$ value.

The following considerations examine how the failure of devices or their components affect the safety of the system, how likely these failures are to occur and how to calculate the SIL.

Determination of common cause failure – CCF factor

The CCF factor is determined through a combination of several individual assessments. One of the first key parameters to examine is the system architecture. Systematic effects in particular need to be assessed, such as the failure of several components due to a common cause. The competence and experience of the developer are also evaluated, along with the analysis procedures. An evaluation scale is used, on which there are 100 points to be assigned.

Requirement	Points
Physical separation of safety circuits and other circuits	25
Diversity (use of different technologies)	38
Design/application/experience	2
Assessment/analysis	18
Competence/training	4
Environmental influences (EMC, temperature, ...)	18

The next step is to determine the β factor (Beta), based on the points achieved using the following table.

	β factor – common cause factor
<35	10 % (0.1)
35-65	5 % (0.05)
66-85	2 % (0.02)
86-100	1 % (0.01)

▶ 3.4 Standards

SIL assessment

In EN 62061, the maximum achievable SIL is determined via the dependency between the hardware fault tolerance and the safe failure fraction (SFF). The SFF is calculated by assessing all possible types of component failures and establishing whether each of these failures results in a safe or unsafe condition. The result provides the system's SFF.

The structural analysis also indicates whether there is any fault tolerance. If the fault tolerance is N, the occurrence of N+1 faults can lead to the loss of the safety function. The following table shows the maximum potential SIL, based on the fault tolerance and SFF.

Safe failure fraction (SFF)	Hardware fault tolerance 0	Hardware fault tolerance 1	Hardware fault tolerance 2
< 60 %	Not permitted	SIL 1	SIL 2
60 %–< 90 %	SIL 1	SIL 2	SIL 3
90 %–< 99 %	SIL 2	SIL 3	SIL 3
99 %	SIL 2	SIL 3	SIL 3

The failure rates λ of the individual components and their λ_D fraction (dangerous failures) can be determined via PFH_D formulas, which are dependent on architecture. These formulas can be extremely complex, but always have the format:

$$PFH_D = f(\lambda_{Di}, \beta, T_1, T_2, DC_i)$$

where

T_2 Diagnostic test interval

T_1 Minimum test interval and mission time

The combined consideration of hardware, fault tolerance, category, DC, PFH_D and SFF provides the following SIL assignment. All conditions must always be met. If one single condition is not met, the SIL has not been achieved.

PFH _D	Cat.	SFF	Hardware fault tolerance	DC	SIL
$\geq 10^{-6}$	≥ 2	$\geq 60\%$	≥ 0	$\geq 60\%$	1
$\geq 2 \times 10^{-7}$	≥ 3	$\geq 0\%$	≥ 1	$\geq 60\%$	1
$\geq 2 \times 10^{-7}$	≥ 3	$\geq 60\%$	≥ 1	$\geq 60\%$	2
$\geq 3 \times 10^{-8}$	≥ 4	$\geq 60\%$	≥ 2	$\geq 60\%$	3
$\geq 3 \times 10^{-8}$	≥ 4	$> 90\%$	≥ 1	$> 90\%$	3

The final step is to compare the required SIL from the risk assessment with the achieved SIL. If the achieved SIL is greater than or equal to the required SIL, the requirement for the implementation is considered to have been met.

▶ 3.4 Standards

3.4.3.9 EN 60204-1

Standard	Harmonised	Title
EN 60204-1:2010	Yes	Safety of machinery Electrical equipment of machines – Part 1: General requirements

The harmonised standard EN 60204-1 considers the electrical safety of non-hand-guided machinery with voltages up to 1000 VDC and 1500 VAC.

Its scope is therefore such that there are very few industrial machines that it does not affect.

3.4.3.10 EN 61508

Standard	Harmonised	Title
EN 61508-1:2010 EN 61508-2:2010 EN 61508-3:2010 EN 61508-4:2010 EN 61508-5:2010 EN 61508-6:2010 EN 61508-7:2010	No	Functional safety of safety-related electrical, electronic and programmable electronic control systems

EN 61508 is the key standard dealing with the functional safety of control systems. It has seven parts in total and all together contains around 1000 pages of text. The whole EN 61508 standards' package was completely revised in 2010 and Edition 2 is now available.

A key component of EN 61508 is the examination of the complete lifecycle from a safety perspective (in Part 1), with detailed requirements of the procedure and the content of the individual steps; it's essential to both machine builders and safety component manufacturers alike.

This standard is also focused on the design of electrical systems and their corresponding software. However, the standard is to be expanded in practice and will frequently apply for other systems as well (mechanics, pneumatics, hydraulics). Manufacturers of safety components such as safety relays, programmable safety systems and safety sensor/ actuator technology are likely to derive the most benefit from this standard. Overall, when it comes to defining safety levels, end users or system integrators are better advised to use the much less complex EN 62061 or EN ISO 13849-1, rather than EN 61508.

Another sector standard of EN 61508 is EN 61511, which is applicable for the process industry sector.

▶ 3.4 Standards

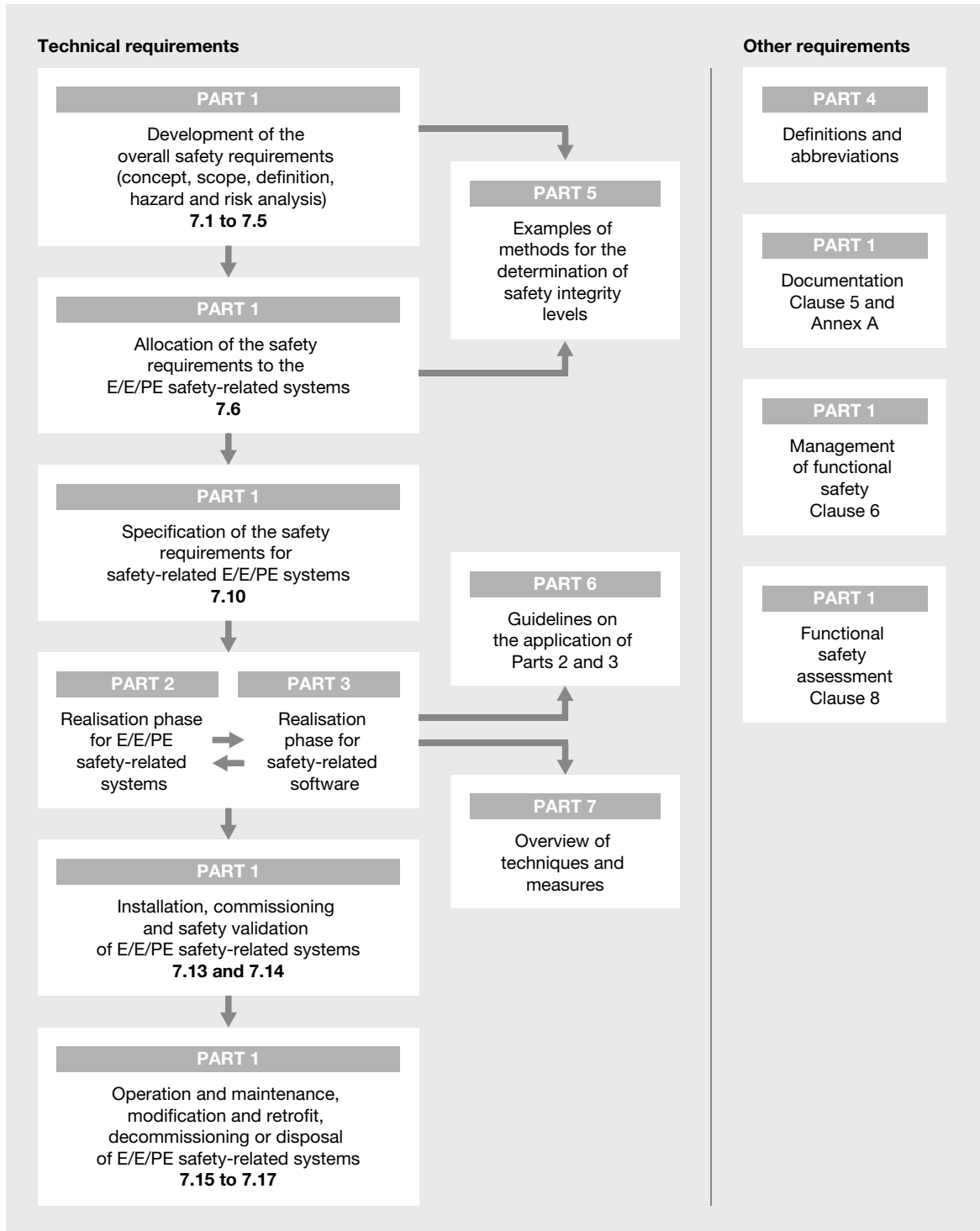

Extract from DIN EN 61508-1, overall framework of the safety assessment in accordance with EN 61508.
Overall framework of the IEC 61508 series of standards

▶ 3.4 Standards

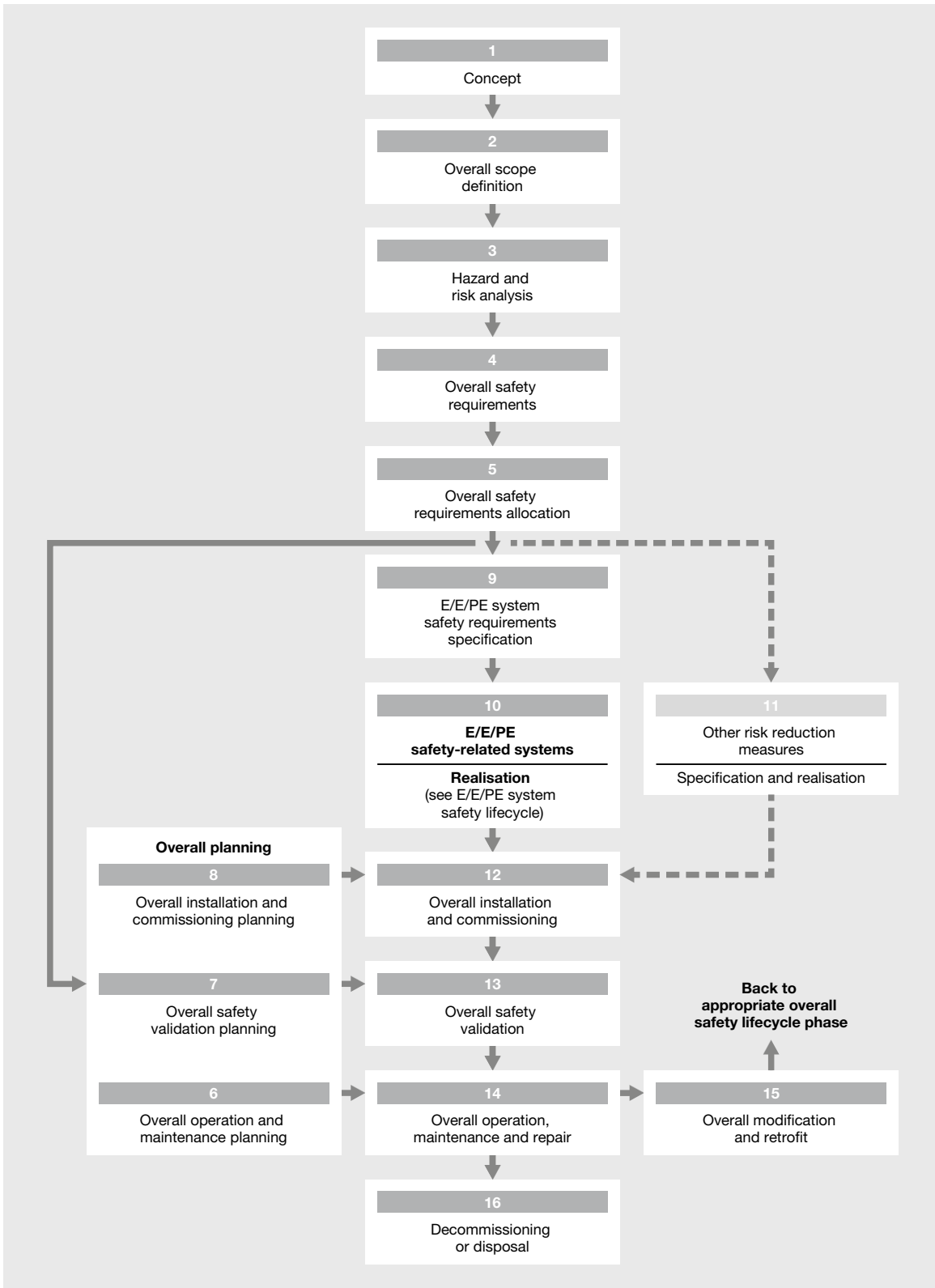

Overall safety lifecycle in accordance with EN 61508-1

▶ 3.4 Standards

3.4.3.12 EN 61326-3

Standard	Harmonised	Title
EN 61326-3 Part 1 and 2:2008	No	Electrical equipment for measurement, control and laboratory use – EMC requirements

With the release of EN 61326-3-1 and EN 61326-3-2, since 2008 there have been two standards providing information on immunity requirements in respect of the EMC level on safety devices. Both parts have been specified with different immunity requirements. Part EN 61326-3-1 is the general section with more stringent requirements. This part was drawn up with a particular view towards mechanical engineering. In contrast, part EN 61326-3-2 was written with a view towards the process industry and the immunity requirements are significantly lower. In engineering, therefore, it should always be ensured that the test

requirements in accordance with EN 61326-3-1 are met as a minimum. As the origin of both these standards is still very recent and there are no forerunners to refer back to, it will still be some time before they are reflected in the relevant device certificates. In general, it is to be noted that product or sector standards also contain EMC requirements, but that these are usually below the requirements specified in EN 61326-3-1.

3.4.4 Product standards

3.4.4.1 EN ISO 14119

Standard	Harmonised	Title
EN ISO 14119:2013	Yes	Safety of machinery Interlocking devices associated with guards. Principles for design and selection
ISO/TR 24119	No	Safety of machinery Evaluation of fault masking in conjunction with interlocking devices with potential-free contacts

The previous standards EN 1088 and ISO 14119 were combined with the publication of EN ISO 14119:2013. The standard deals with guards, i.e. gates, covers or flaps, plus sensor technology that detects the position of such devices. The standard also covers guard locking devices.

The purpose of the standard is also to specify exact requirements to improve provisions for reducing the ability of the machine operator to defeat safety equipment. Investigations have shown that operators often attempt to defeat the safety function of an interlocking guard by defeating the

interlock. The ability to defeat safety equipment can mainly be attributed to deficiencies in the machine design. ISO/TR 24119 will be published at the same time as EN ISO 14119; this is a spin-off from EN ISO 14119. ISO/TR 24119 deals with only one subject: evaluation of interlinked safety gate switches. The context is the recurring accumulation of faults in conjunction with applications of this type, which can lead to the loss of the safety function for the plant.

▶ 3.4 Standards

3.4.4.2 EN 61496 and IEC/TS 62046

Standard	Harmonised	Title
IEC/TS 62046:2008	No	Safety of machinery Application of protective equipment to detect the presence of persons
EN 61496-1:2012	Yes	Safety of machinery Electrosensitive protective equipment – Part 1: General requirements and tests
IEC 61496-2:2013	No	Safety of machinery Electrosensitive protective equipment – Part 2: Particular requirements for equipment using active optoelectronic protective devices (AOPDs)
CLC/TS 61496-3:2008	No	Safety of machinery Electrosensitive protective equipment – Part 3: Particular requirements for active optoelectronic protective devices responsive to diffuse reflection (AOPDDR)

While the 61496 series describes product-specific requirements of electrosensitive protective equipment, IEC/TS 62046 focuses on the selection and measurement of electrosensitive protective equipment such as light beam devices, light grids or scanners. As such, it is one of the key standards for machine builders when it comes to designing machine access areas and safeguarding material channels.

The EN 61496 series of standards considers electrosensitive protective equipment. This includes devices such as light grids, laser scanners, light beam devices, safe camera systems and other sensors, which can all be used for non-contact protection. As EN 61496 is a product standard for safety components, it is only relevant for the typical user if the safety components he has used are intended to conform to these standards.

▶ 3.4 Standards

3.4.4.3 EN 61800-5-2

Standard	Harmonised	Title
EN 61800-5-2:2007	Yes	Adjustable speed electrical power drive systems Part 5-2: Safety requirements – Functional

The EN 61800-5-2 is aimed at both drive manufacturers and users. It deals with the issue of drive-based safety, but without specifying any requirements regarding safety-related suitability. No safety level is established, nor is there any definite hazard or risk evaluation. Instead, the standard describes mechanisms and safety functions of drives in an application environment, and how these are verified and planned within the drive's lifecycle. Technologically, the standard is based on EN 61508, even though proximity with EN ISO 13849-1 might have been anticipated, given the ever-present mechanical aspect of the drives.

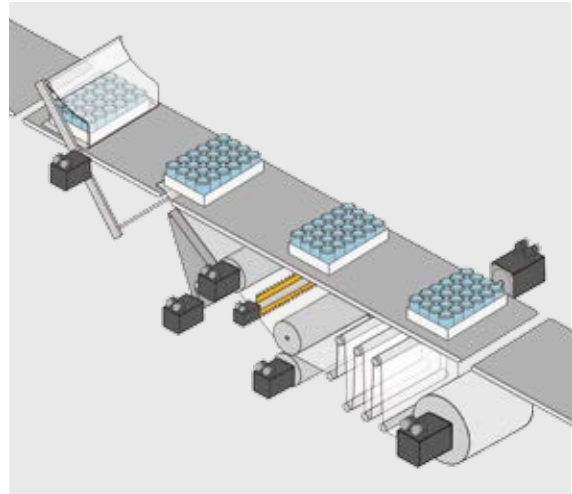

Manufacturers of safe drives focus on EN 61800-5-2.

▶ 3.4 Standards

3.4.5 Application standards

3.4.5.1 EN ISO 11161 Integrated manufacturing systems

Standard	Harmonised	Title
EN ISO 11161:2010	Yes	Safety of machinery Integrated manufacturing systems – Basic requirements

This standard deals with the safety aspects when assembling machines and components into a manufacturing system (IMS). It does not deal with the requirements of the individual components and machines.

The standard is of particular interest to operators and system integrators who operate or design machine pools and plants incorporating machines and components. This standard should be applied in close co-operation with EN ISO 12100.

3.4.5.2 NFPA 79

Standard	Harmonised	Title
NFPA 79:2015	No	Electrical standard for industrial machinery

This standard is mainly important for the US market, though it is also applied in Asia. It is very similar to the European standard EN 60204-1.

The standard is concerned with the safe electrical design, the operation and the inspection of industrial machinery.

▶ 3.5 International comparison of standards, directives and laws

The highly comprehensive system for the EU directives established in Europe with the corresponding harmonised standards in combination with the CE conformity assessment procedure and CE marking procedure for safety components, plant and machinery, is not automatically accepted around the world. In certain countries, other legally binding laws, directives and standards apply which are then to be observed and implemented for smooth export. Safe plant and machinery also contribute to increasing occupational safety in these countries on principle, even though the classification of the country-specific requirement and implementation level varies widely and generally the high level of safety in Europe will assuredly not be reached. This safety compendium is mainly concerned with European standards, directives and laws. However, the following section provides a brief overview of the situation outside of Europe and in other parts of the world.

3.5.1 Directives and laws in America

3.5.1.1 North America (USA + Canada)



USA

Other laws, directives and standards generally apply in the USA compared to Europe with regard to safety requirements for plant and machinery. CE mark and CE declaration of conformity have no legal acceptance. An export solely based on CE conformity is definitely illegal and to be categorised as very critical with regard to product liability.

In general, plant and machinery cannot be commissioned in the USA without approval by special officials from the states, counties or municipalities, the so-called authorities having jurisdiction (AHJ). These inspectors are responsible for the approval of electrical building and machine safety (electrical building/field inspector), explosion protection (hazardous location inspector) or the safety of pressure equipment (pressure and vessels code inspector), for example. Without their approval, there is generally no commissioning. When safety deviations are determined, shutdown until the defect is rectified is usually possible using a red tag. This results in complex and expensive retrofitting and conversion measures on-site in the USA by the manufacturer and, where applicable, any contractually agreed penalties for non-performance incurred due to delayed commissioning.

The Occupational Safety and Health Administration (OSHA), a sub-agency of the US Department of Labor, is responsible for defining and monitoring basic health and safety measures in the USA. They specify minimum requirements in the OSHA standards; these can be found in the Code of Federal Regulations (CFR) under 29 CFR 1910. These are primarily directed at machine and plant operators.

The situation is somewhat more complicated in terms of plant and machine safety from the manufacturer's point of view.

▶ 3.5 International comparison of standards, directives and laws

First of all, there is no uniform standards system in the USA with one issuer of standards as is the case in Europe with CEN/CENELEC and the EN standards. There are a number of accredited drafters that can develop and publish standards. These are usually manufacturers' associations. The most prominent and most well-known in Europe are:

- ▶ ANSI American National Standards Institute
- ▶ NEMA National Electrical Manufacturers Association
- ▶ NFPA National Fire Protection Association
- ▶ UL Underwriters Laboratories

However, in most cases there is no legal application requirement for these type of norms in the plant and machinery sector. According to the critical USA product liability law, however, a manufacturer must always use a search of standards to ascertain which standards are applicable for his plant and machinery. If there is product-specific applicability, the normative requirements should also be completely and correctly implemented in the plant and machinery. This prevents unnecessary product liability risks.

Examples of standards always to be observed and applied include:

- ▶ NFPA 70 – National Electrical Code (NEC)
- ▶ NFPA 79 – Electrical Standard for Industrial Machinery
- ▶ UL 508A – Industrial Control Panels

This list makes it clear that the electrical safety of plant and machinery is of particular significance.

Mechanical safety is less important compared to the harmonised European standards and is also not of significance during the approval by the above inspectors.

Comprehensive product standards as found in Europe for the electrical and mechanical safety of plant and machinery therefore do not exist in the USA. There is only the series of standards ANSI B11 for plant and machinery for metalworking, such as machine tools or forming machines, which also contains clear mechanical safety requirements in addition to the electrical requirements.

With regard to mechanical plant and machine safety in the USA, the general position can be taken that a consistent implementation of mechanical safety requirements based on the harmonised A, B and C standards in accordance with the European Machinery Directive provides a significant basis for satisfying the safety requirements that apply in the USA.

Please contact Pilz with any concrete questions about special national considerations for machine and plant safety. The Pilz subsidiary in the USA together with the internationally established Pilz services for automation, plant and machine safety are available to provide targeted support for any country-specific questions on this topic.

▶ 3.5 International comparison of standards, directives and laws

Canada

Other laws, directives and standards generally apply in Canada compared to Europe with regard to safety requirements for plant and machinery. CE mark and CE declaration of conformity have no legal acceptance. An export solely based on CE conformity is definitely illegal and not encouraged for reasons relating to product liability.

In general, no machine or plant is commissioned in Canada without approval by special officials from the provinces, the so-called safety authority officers (SAO). The term authorities having jurisdiction (AHJ) is also used in Canada, however. These safety inspectors are responsible for the approval of electrical building and machine safety (electrical building/field inspector), explosion protection (hazardous location inspector) or the safety of pressure equipment (pressure and vessels code inspector), for example. Without their approval, there is generally no approval of commissioning. When safety deviations are determined, shutdown until the defect is rectified is possible.

This results in complex and expensive retrofitting and conversion measures on-site in Canada by the manufacturer and, where applicable any, contractually agreed penalties for non-performance incurred due to delayed commissioning.

The Canadian Centre for Occupational Health and Safety (CCOHS) is responsible for defining and monitoring basic health and safety measures in Canada. This Canadian office is comparable with OSHA in the USA (see 3.5.1.1/USA) and also defines the minimum requirements for health and safety for plant and machinery that primarily apply for the plant and machine operator.

The situation in Canada is somewhat simpler in terms of plant and machine safety from the manufacturer's point of view compared to the USA.

Unlike in the USA, there is a uniform standards system in Canada with one issuer of standards, the Canadian Standards Association (CSA), as is also the case in Europe with CEN/CENELEC and the EN standards. There is therefore only one type of standard in Canada, the CSA standards. However, in most cases there is no legal application requirement for these type of norms in the plant and machinery sector. Despite the less strict Canadian product liability law, a manufacturer should still always use a search of standards to ascertain which standards are applicable for his plant and machinery. If there is product-specific applicability, the normative requirements should also be completely and correctly implemented in the plant and machinery. This prevents unnecessary product liability risks.

Examples of Canadian standards always to be observed and applied include:

- ▶ CSA 22.1 – Canadian Electrical Code (CEC)
- ▶ CSA 22.2 No.286 – Industrial Control Panels and Assemblies
- ▶ SPE 1000 Model Code for the Field Evaluation of Electrical Equipment

This list makes it clear that the electrical safety of plant and machinery is of particular significance.

Mechanical safety is less important compared to the harmonised European standards and is also not of significance during the approval by the above inspectors.

Comprehensive product standards as found in Europe for the electrical and mechanical safety of plant and machinery therefore do not exist in Canada.

▶ 3.5 International comparison of standards, directives and laws

There is an important Canadian standard that must be observed, however, that handles machine safeguards:

▶ Z432 – Safeguarding of Machinery

This standard contains both basic electrical and mechanical requirements of such safeguards, irrespective of the type of plant or machine, and is comparable with the status of a European A standard or at most a B standard.

With regard to mechanical plant and machine safety in Canada, the general position can be taken that a consistent implementation of mechanical safety requirements based on the harmonised A, B and C standards in accordance with the European Machinery Directive provides a significant basis for satisfying the safety requirements that apply in Canada.

Please contact Pilz with any concrete questions about special national considerations for machine and plant safety. The Pilz subsidiary in Canada together with the internationally established Pilz services for automation, plant and machine safety are available to provide targeted support for any country-specific questions on this topic.

3.5.1.2 South America

With the exception of Brazil, there are currently no product-specific safety requirements for plant and machinery that are concrete and applicable for South American countries. There are national standards organisations that develop national standards and convert ISO or IEC standards in particular to national standards. At the moment the focus here is almost exclusively on standards for consumer products, however. A case-specific check of the safety requirements that must be met is therefore recommended for the export of plant and machinery to South America, for example by means of concrete inquiry in written form to the client/purchaser and/or operator. Even if the

European directives and their harmonised standards enjoy a certain importance in South America with regard to safety, you must not automatically assume a general acceptance.

Brazil



As of 2010, there is a national law in Brazil that stipulates minimum safety requirements for machines and (machine) equipment:

▶ Norma Regulamentadora 12 (NR-12) – MÁQUINAS E EQUIPAMENTO

The law has been in place since 1978, without really having been consistently implemented and enforced by the authorities. With the last – essentially complete – revision in 2010, measures for monitoring by the authorities were implemented thus rendering NR-12 essentially binding.

▶ 3.5 International comparison of standards, directives and laws

During the revision, it was adapted to the European Machinery Directive 2006/42/EC to a great extent. The safety requirements from Annex I of the Machinery Directive including individual special requirements for certain machine types were actually adopted wherever possible. In Europe, this law is therefore also referred to as the “Brazilian Machinery Directive”.

NR-12 primarily targets the machine operator and applies for old, used and new machines in contrast to the European Machinery Directive.

A declaration of conformity as confirmation of the implemented safety requirements in accordance with NR-12, as stipulated in Europe, is currently not required from the operator or the manufacturer. In this case, the operator must verify that the plant or machinery satisfies the requirements in accordance with NR-12. The reverse conclusion here is that when exporting machines to Brazil, a company is generally confronted with an operator with corresponding demands. The authorities namely impose corresponding compulsory measures on the operator to ensure implementation in the event of non-compliance with NR-12.

One of the demands that is simple but still not to be underestimated is the provision of operating, installation and maintenance manuals in Brazilian Portuguese. This is not identical to the language version for the EU country Portugal.

A harmonised standardisation to NR-12 currently does not exist but initial consideration and discussion on the national level is currently underway with regard to gradually supplementing NR-12 with harmonised standards, building on the European harmonisation system. In this context, the possibility of certification, e.g. for safety components, is being considered. Practical implementation is currently by no means foreseeable, however.

In terms of standardisation, the Brazilian standards organisation Associação Brasileira de Normas Técnicas (ABNT) develops the country-specific national standards NBR (Norma Brasileira Regulamentadora), but also increasingly converts ISO and IEC standards to national standards. The currently valid versions of ISO and IEC standards are often not adopted, however; instead older versions are used. The standardisation system is therefore to be considered comprehensive but in most cases not to the current status of international or European standardisation.

A valid reverse conclusion is that plant and machinery built in accordance with current European directives and harmonised standards with CE conformity generally have excellent preconditions for problem-free commissioning in Brazil. A case-specific check of the safety requirements that must be met is still recommended for the export of plant and machinery to Brazil, for example by means of concrete inquiry in written form to the client/purchaser and/or operator.

Please contact Pilz with any concrete questions about special national considerations for machine and plant safety. The Pilz subsidiary in Brazil together with the internationally established Pilz services for automation, plant and machine safety are available to provide targeted support for any country-specific questions on this topic.

► 3.5 International comparison of standards, directives and laws

3.5.2 Directives and laws in Asia

3.5.2.1 Russia/Russian Federation



Until 2011, plant and machinery were required to produce a GOST-R certificate under certain preconditions to be eligible for import in the Russian Federation. The (international) customs tariff number (HS code – Harmonized Commodity Description and Coding System) helped to form the basis as a criterion for determining products requiring certification.

In September 2009 a decree by the Russian Federation came into effect that stipulates basic minimum requirements for safety for machines and equipment as well as a mandatory conformity assessment procedure combined with a certification procedure:

- N 753 Decree of the Government of the Russian Federation – Technical Regulation (TR) on safety of machines and equipment

The basis is a contractual harmonisation process between the EU and the Russian Federation to align the different safety-related regulation and conformity assessment procedures for machinery in the Russian Federation. The decree includes two annexes, one a list of the machines requiring certification and one with machines for which a Russian declaration of conformity is sufficient.

Obligation for certification

With an obligation for certification, the machine must be checked by a locally accredited test laboratory and a TR certificate must be issued. The procedure is comparable to a type examination in accordance with the Machinery Directive.

Declaration of conformity

If a declaration of conformity is sufficient, this must still be additionally checked, approved and registered by a nationally accredited certification body. This type of declaration of conformity is NOT a self-certification by the machine manufacturer as permissible and common in Europe in accordance to the Machinery Directive and the corresponding harmonised standards.

The customs tariff number still plays a certain role here as there is a comprehensive list containing all products, meaning not only machines, that require certification or conformity.

The basis for ensuring machine safety is formed by the Russian standards GOST (Gossudarstwenny Standart). There are currently a large number of machine-specific safety standards. In addition to the national Russian GOST-R standards, ISO and IEC standards are increasingly being converted into GOST R ISO, GOST ISO, GOST R IEC or GOST IEC, either with deviations or even with as little modification as possible. Furthermore, EN standards from the harmonised section of the European Machinery Directive have been and continue to be adopted as Russian GOST EN standards if no comparable machine-related ISO and IEC standards exist.

Since July 2010, a customs union (CU) between the three Eurasian countries of Russia, Belarus and Azerbaijan has come into effect. This was expanded in 2015 to include the countries of Armenia and Kyrgyzstan. In the medium and long term, this customs union is to incorporate additional post-Soviet states.

▶ 3.5 International comparison of standards, directives and laws

The TR for machinery is valid in all countries in the customs union and the relevant Russian GOST standards are recognised as the basis for conformity.

The EAC (EurAsian Conformity) is an independent Eurasian conformity mark that exists as an externally visible mark:



Please contact Pilz with any concrete questions about special national considerations for machine and plant safety. The Pilz subsidiary in Russia together with the internationally established Pilz services for automation, plant and machine safety are available to provide targeted support for any country-specific questions on this topic.

3.5.2.2 Japan



The Japanese Industrial Safety and Health Law places demands on design issues relating to certain machinery (cranes, lifts etc.). The law also states that the machine operator is responsible for carrying out risk analyses. He also has to ensure safety in the workplace. It is assumed that the machine operator will ask the machine manufacturer to issue a risk analysis report at the time of purchase and that the machine is designed safely. The law also contains requirements for pressure vessels, packaging machines for the food industry and mobile machines.

Japan generally adopts the IEC and ISO standards as national JIS standards (Japanese Industrial Standards); however, the Industrial Safety and Health Law does not directly refer to each of these standards. There is therefore no legal obligation to actually apply and implement these JIS standards.

There are currently no concrete obligations for acceptance or approval for plant and machinery.

▶ 3.5 International comparison of standards, directives and laws

3.5.2.3 China



In China the State Administration of Work Safety is responsible for defining and monitoring health and safety measures. Monitoring is guaranteed by local health and safety inspectors. Chinese machine safety standards are used for plant and machinery.

Furthermore, since May 2002 China has had its own Chinese certification system – Chinese Compulsory Certificate (CCC). The CCC mark is used to mark certified products:



There is currently an obligation for certification for 23 product categories with 132 product groups from the consumer, electronic and industrial product branches.

Plant and machinery are not subject to this. The internationally harmonised customs tariff number, called the HS code (Harmonized Commodity Description and Coding System), is an important search criterion for an existing obligation for certification in the Chinese customs manual. An additional search criterion is checking whether the Chinese standard valid for a product is marked as mandatory.

China has an independent national standards system; the Standardization Administration of China (SAC) is responsible for developing this. This standards organisation issues the national GB or GB/T standards.

- ▶ GB = Guobiao, meaning national standard
- ▶ GB/T = Guobiao/Tujian, meaning recommended national standard. Becomes mandatory if referenced in GB standards

In the area of machine safety, the SAC generally adopts international ISO and IEC standards, in many cases only with national deviations and not based on the most current international versions of the standard.

If there are no international standards, in some cases European EN standards harmonised for the Machinery Directive are converted in the same manner into national Chinese standards. An application problem stems from the publication in Chinese language, English language official standard versions are, however, currently only available in exceptional cases.

Please contact Pilz with any concrete questions about special national considerations for machine and plant safety. The Pilz subsidiary in China together with the internationally established Pilz services for automation, plant and machine safety are available to provide targeted support for any country-specific questions on this topic.

▶ 3.5 International comparison of standards, directives and laws

3.5.2.4 South Korea



In South Korea, the Korea Occupational Safety & Health Agency (KOSHA) is the governmental agency responsible for developing, implementing and monitoring health and safety measures. The Korean Occupational Safety & Health Act forms the basis for KOSHA's work. An important element of the monitoring performed by KOSHA is the approval procedure for various safety components, machines and plants. The system of 13 existing certifications with legal obligation that existed until December 2008 was converted into a new uniform certification system; this was bindingly implemented with a transition period beginning in June 2011. This is signalled on plant and machinery using the KCs mark (Korean Certification Safety Mark)



and documented by means of a certificate. The following nationally accredited testing institutes are responsible for the certification:

- ▶ ERI – EMC Research Institute
- ▶ KETI – Korea Electronics Technology Institute
- ▶ KTL – Korea Testing Laboratory

There are two different certification or approval procedures that are to be requested by the machine and plant manufacturer as the importer before export; these must be performed with a positive test result:

Mandatory certification for hazardous machinery

For hazardous machinery, a complete machine test must be performed by an independent locally accredited test laboratory. This test procedure is legally prescribed for cranes, pressure vessels, lifts, mobile lifting platforms, certain inclined lifts, presses, press brakes, rolling machines, injection moulding machines and hand-held chain saws. In terms of content, this test procedure is roughly comparable to a type examination in accordance with Annex IV of the Machinery Directive.

Self-certification by the machine manufacturer

Here, the machine manufacturer must use comprehensive documentation to verify to a locally accredited test laboratory that the safety requirements/standards relevant in South Korea for the respective machine type have been applied, implemented, checked, documented and thus satisfied. This procedure can be applied for the following stationary machine types: industrial robots, grinding machines, machine tools, woodworking machines, printing presses, mixing and shredding machines, food preparation machines, conveyors and vehicle lifts. The documents to be provided are comparable with the document creation for a complete EU conformity assessment procedure in terms of content.

Please contact Pilz with any concrete questions about special national considerations for machine and plant safety. The Pilz subsidiary in South Korea together with the internationally established Pilz services for automation, plant and machine safety are available to provide targeted support for any country-specific questions on this topic.

▶ 3.5 International comparison of standards, directives and laws

3.5.3 Directives and laws in Oceania

3.5.3.1 Australia



Since 2013, a broadly uniform law for necessary health and safety measures to be implemented has applied in four of the continent's six states and its two territories. The national office Safe Work Australia is responsible for developing and defining the legal framework conditions and for monitoring. The national law Work Health and Safety Act (WHS) forms the basis for health and safety.

Only the states Victoria and West Australia have developed and implemented their own health and safety requirements as Occupational Health and Safety Acts.

The defined health and safety measures are generally legally binding and must therefore be observed. There are various application and implementation guidelines, called the Model Codes of Practice. These primarily directly target the local operator and not the manufacturer of plant and machinery. Nevertheless, a manufacturer must deal with this in order to avoid potential problems during the commissioning in Australia. The monitoring is performed by inspectors in the respective states and territories.

As a member of the British Commonwealth, Australia traditionally follows Great Britain's administrative procedures. This is also noticeable in the health and safety measures thanks to commonalities – important for machine and plant manufacturers – with the European Machinery Directive and the associated harmonised standardisation.

Australia has its own standards system; Standards Australia is responsible for developing this. This standards organisation issues the Australian Standards (AS) national standards. The following AS standards apply for the machine safety sector:

- ▶ Standard series AS 4024.xxxx – Safety of machinery
- ▶ AS 60204.1 – Electrical equipment of machines, general requirements
- ▶ Standard series AS IEC 61511.x – Functional safety in process industry
- ▶ AS 62061 Safety of machinery – Functional safety electrical, electronic and programmable electronic control systems

These standards are always to be observed, even if there are currently no concrete requirements for legally binding implementation from Australian health and safety legislation. The Australian machine safety standard is based primarily – but not completely – on the acceptance of ISO or IEC standards and also standards harmonised for the European Machinery Directive. The current version of an international or European standard has not always been adopted, however.

Please contact Pilz with any concrete questions about special national considerations for machine and plant safety. The Pilz subsidiary in Australia together with the internationally established Pilz services for automation, plant and machine safety are available to provide targeted support for any country-specific questions on this topic.

▶ 3.5 International comparison of standards, directives and laws

3.5.3.2 Directives and laws in New Zealand



Since 2015, the Health and Safety Work Act (HSW) has applied in New Zealand for necessary health and safety measures to be implemented. The national office WorkSafe New Zealand is responsible for developing and defining the legal framework conditions and for monitoring.

The defined health and safety measures are generally legally binding and must therefore be observed. There are various application and implementation guidelines, which primarily directly target the local operator and not the manufacturer of plant and machinery. Nevertheless, a manufacturer must deal with this in order to avoid potential problems during the commissioning in New Zealand.

The monitoring is also performed by local inspectors in New Zealand.

As a member of the British Commonwealth, New Zealand traditionally follows Great Britain's administrative procedures. This is also noticeable in the health and safety measures thanks to commonalities – important for machine and plant manufacturers – with the European Machinery Directive and the associated harmonised standardisation. New Zealand has its own standards system; Standards New Zealand is responsible for developing this. This standards organisation issues the New Zealand Standards (NZS) national standards.

The corresponding Australian AS standards are generally adopted as AS/NZS standards for the machine safety sector:

- ▶ Standard series AS/NZS 4024.xxxx – Safety of machinery

These standards are always to be observed, even if there are currently no concrete requirements for legally binding implementation from New Zealand health and safety legislation.

Like the AS standards, the New Zealand machine safety standard is also based on the acceptance of ISO or IEC standards and also standards harmonised for the European Machinery Directive. The current version of an international or European standard has not always been adopted, however.

Please contact Pilz with any concrete questions about special national considerations for machine and plant safety. The Pilz subsidiary in New Zealand together with the internationally established Pilz services for automation, plant and machine safety are available to provide targeted support for any country-specific questions on this topic.

▶ 3.5 International comparison of standards, directives and laws

3.5.4 Summary

The brief – and certainly incomplete – comparison of European and global requirements for machine and plant safety is solely intended to highlight the at times extremely varied and above all highly inconsistent situation with regard to safety requirements for plant and machinery outside of Europe.

The machine and plant manufacturer must therefore deal with the special country-specific laws, directives and standards relevant for his product and familiarise himself with these in good time. This is the basic requirement for what is then highly problem-free export of plant and machinery outside of Europe.

In general, however, it can be said that compliance with and actual implementation of the EU directives and harmonised standards relevant for the respective plant and machinery is a major precondition for being able to export plant and machinery globally while keeping the time and cost relatively manageable.

This also shows the general significance of the European directive concept with the highly detailed harmonised standards system in particular, even in the international sector. There is currently no country in the world outside of the EU that has this type of comprehensive safety concept for plant and machinery that covers practically all safety-related sectors and still remains uniform. Machine and plant manufacturers can depend on this, even though the CE mark and CE declaration of conformity do not enjoy any real legal acceptance globally. The idea – that many machine and plant manufacturers still entertain – that CE conformity practically translates into a free pass for global export is plain wrong. In the end, this is essentially “only” a self-certification by the manufacturer that claims that he observed, applied and actually implemented all directives and harmonised standards that apply to his product. And various countries outside of Europe only trust this to a limited extent.

▶ 3.6 Industrial robot, human-robot collaboration (HRC)

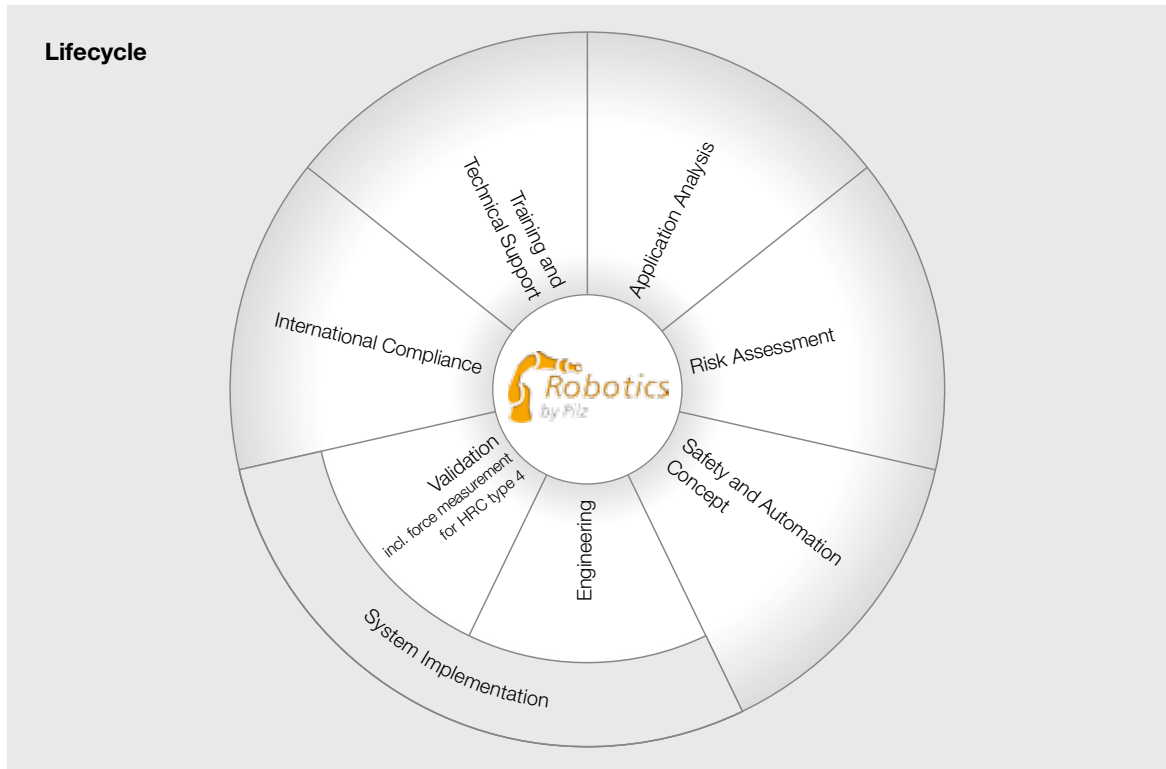

Analysis of the application

Documentation of the main peripheral devices of the planned robot application. The process and safety-related requirements, such as cycle time, repetition accuracy, workplace, hazardous areas, etc., are integrated into the rough plans for the system. Technical and economic evaluation then take place.

Risk assessment

Review of the robot application in accordance with the applicable standards and directives and assessment of the existing hazards.

Safety concept

Development of a detailed technical solution for the safety of the robot application through mechanical, electronic and organisational measures.

Safety design

By detailed elaboration of the necessary protective measures, the danger zones of the application are reduced or eliminated.

System implementation

The results of the risk assessment and safety concept are implemented to suit the particular requirements through selected safety measures.

Validation

Examination and mirroring of the risk assessment and safety concept as well as performance of the collision measurement in accordance with ISO/TS 15066 limit values.

International compliance

Ensuring that the machinery conforms to the regulatory requirements, be it CE marking in Europe for example or OSHA in the US, NR-12 in Brazil, KOSHA in Korea, GOST in Russia or CCC in China.

Training and technical support

Dissemination of expertise relating to the safe application of robots.

▶ 3.6 Industrial robot, human-robot collaboration (HRC)

3.6.1 Normative specifications for the use of industrial robots

As per Machinery Directive 2006/42/EC, a robot system is partly completed machinery. This means that robot systems are initially to be classified as not safe and require CE marking.

This is due to the fact that taken by itself, a robot does not have any specified purpose. Its intended use is only defined by the integrator, who creates the robot application and equips the robot with a tool.

The integrator is the person placing the machine on the market (robot cell). He must perform the conformity assessment procedure, which concludes with the EC Declaration of Conformity.

For detailed safety requirements, the two standards ISO 10218 “Safety of Industrial Robots” Part 1: “Robots” and Part 2: “Robot systems and integration” were previously available.

The English versions of both parts are published as EN ISO 10218-1:2011 and EN ISO 10218-2:2011 and are listed under the Machinery Directive 2006/42/EC.

EN ISO 10218-1 is solely concerned with the actual robot system.

In contrast to this, EN ISO 10218-2 expands the perspective to the entire robot application.

Both standards are type C standards. This means these are product-specific standards that are arranged above the type A and type B standards in the hierarchy.

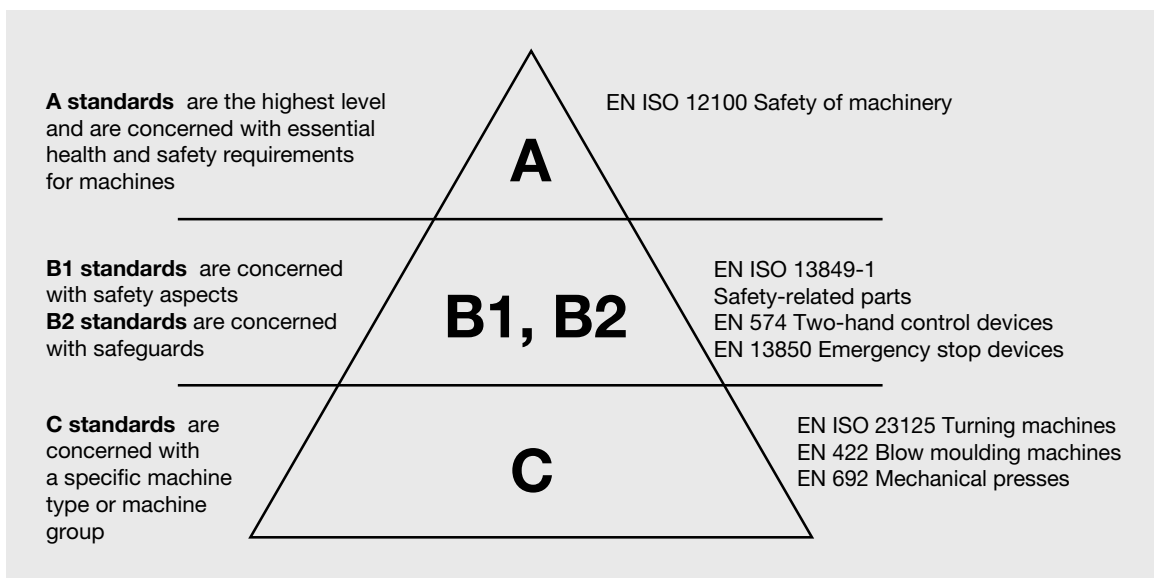

In practice, however, the standards have proved to be insufficient when it comes to safely implementing an actual collaboration between man and machine in which the respective work areas can overlap in terms of time and space. The standards contained a loophole, which has been closed with the publication of ISO/TS 15066.

HRC requires protective measures to ensure that human safety is guaranteed at all times during collaborative operation. ISO/TS15066 describes in detail four types of collaboration as protection principles. In addition, the maximum permissible biomechanical limit values for a collision between humans and robots are defined here.

▶ 3.6 Industrial robot, human-robot collaboration (HRC)

3.6.2 Robot applications from the perspective of EN ISO 10218-2

As mentioned above, EN ISO 10218-2 has a broader focus. It examines the entire robot application.

A robot cell can be comprised of the following components:

- ▶ Industrial robots
- ▶ End effector (robot tool)
- ▶ Workpiece
- ▶ Machine equipment

In contrast to rotative drive technology, the safety functions are not clearly named and specified in standards for robotics.

Safety functions of the industrial robot system may include:

- ▶ Safe stop
- ▶ Safely reduced speed
- ▶ Safe axis limitation
- ▶ Safe workspace monitoring
- ▶ Etc.

The detailed specification is always specific to the manufacturer, however, and can vary. For this reason, it is very important to inspect the certificates of the respective manufacturers to be able to classify the performance level of the safety functions.

The performance level of safety-related parts in control systems is described in Chapter 5.2 of EN ISO 10218-2. Under 5.2.2 a dual-channel control structure is specified, PL d, Cat. 3 as per EN ISO 13849-1.

3.6.3 Human-robot collaboration and ISO/TS 15066

EN ISO 10218-2 only touches on the topic of human-robot collaboration. For this reason, the technical specification ISO/TS 15066 was created. This has been available since February 2016 and discusses the topic of HRC in detail.

Four types of collaboration are described in TS 15066 as protection principles. These four methods can be applied individually to safeguard HRC applications. Each individually – or as a combination.

Method 1: Safety-rated monitored stop

The human only has access to the robot once stopped (“safety-rated monitored stop”). Aspects of sensor technology are not discussed here.

The robot system must not start up again automatically and unexpectedly. This could occur due to faults in the safety-related parts of the control systems, for example.

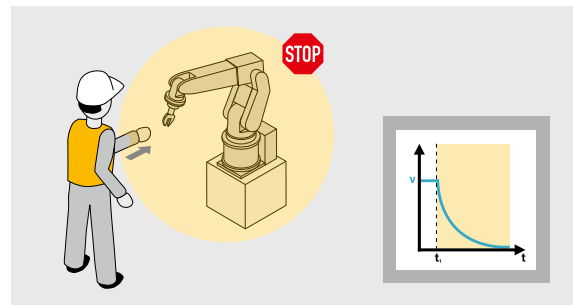

Method 2: Hand guiding

The human also only has access to a stationary robot here. The hand guiding of the robot system can only be enabled by manually operating an enabling device.

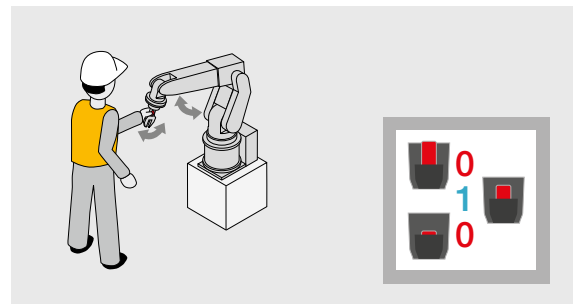

► 3.6 Industrial robot, human-robot collaboration (HRC)

Method 3: Speed and separation monitoring

With this method, the distance between human and robot is permanently monitored by a sensor. The robot system moves with correspondingly safely reduced speed.

The closer the human gets to the robot, the slower the robot becomes. If the distance is too short, a safety stop is triggered.

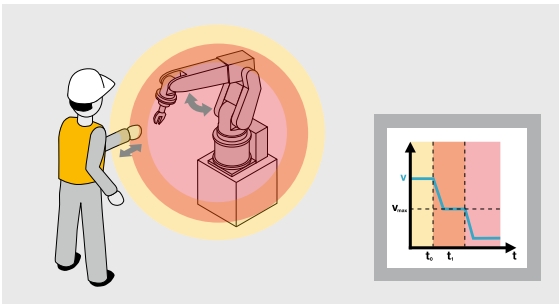

There is currently no sensor technology on the market that can completely map method 3 in a safety-related manner.

In a static variant, this is currently possible with scanners or SafetyEYE.

Safety is guaranteed in the first three methods by maintaining the distance between human and machine. A collision between human and robot is not permissible here. When implementing one of these three methods, no special HRC robots are necessary. Standard industrial robots can be used that are equipped with corresponding safety packages for speed monitoring or workspace monitoring by the manufacturer.

Method 4: Power and force limiting

In contrast to methods 1 to 3, with method 4 contact between human and robot is possible “under certain circumstances”. The manufacturer of the application must guarantee, however, that the collision between human and robot is not hazardous to the human.

The manufacturer of the application confirms this with a signature on the declaration of conformity.

A safe HRC application requires robot systems that are specifically designed for the respective collaboration type. The risk reduction can be implemented either through application of the types of collaboration or by means of an inherently safe design of the robot and the workspace. Inherent in this case means that the robot system cannot generate a hazardous collision due to its design properties.

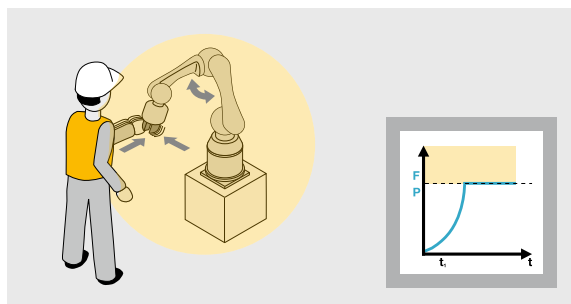

▶ 3.6 Industrial robot, human-robot collaboration (HRC)

Reduced force/power robot

A robot system that “feels” the collision due to its sensor technology and then stops its movement. This collision detection is implemented using parts of the robot control system. With regard to the requirements that are valid for safety-related parts of control systems, TS 15066 refers back to the previously discussed Chapter 5.2 of EN ISO 10218-2 (PL d, Cat. 3).

Collisions can thus be mitigated in a number of ways: through design measures such as rounded edges and corners, padding, or the largest possible contact surfaces so as to distribute the force over the surface. Technical protective measures may also be used (e.g. reducing the dynamics of the robot movements and adapting the robot’s trajectory to avoid collisions with particularly sensitive body regions). Staff training can also help to reduce the risk of injury.

Finally however, it is absolutely essential that a measuring procedure is used to calculate whether the potential collisions are harmless from the point of view of safety. Annex A of the Technical Specification ISO/TS 15066 provides a body model with 29 specific body areas, divided into twelve body regions.

The body area model provides details of the respective pain threshold for each part of the body (e.g. on the head, hand, arm or leg) with a view to force and pressure. The limit values designate when the pain begins.

These limit values define the maximum force to which the corresponding body region can be exposed during a collision. The most sensitive area is the head. It should be possible to rule out a collision with the head during the intended use to the greatest possible extent. If the application remains within these limits during contact between human and robot, it conforms to the standard.

The ISO also clearly differentiates between the type of collision. There are two different types of collision:

- ▶ **The transient contact** between human and robot. This corresponds to an impact from the robot. The human is hit by the robot but has the chance to retreat. He is not trapped. This type of collision is considered by TS 15066 to be less dangerous than the quasi-static contact. For this reason, the TS allows double the limit values for a collision in which the human is not crushed. The head is an exception. The limit values are not allowed to be doubled here.
- ▶ **The quasi-static contact** between human and machine. This contact corresponds to crushing of the human. There is a counter surface (application or building structures) in the immediate vicinity of the human. Avoidance is not possible, the corresponding body region is crushed and the person is possibly trapped and cannot free himself. The TS only allows double the limit values for the first 0.5 s of the collision. This is not valid for body regions that affect the head, however.

▶ 3.6 Industrial robot, human-robot collaboration (HRC)

3.6.4 Validation

Validation means checking the real application. All risk-reducing measures from the risk assessment are again checked for implementation and completeness.

The application should be completely set up and ready for delivery.

The validation phase of a robot cell comprises the following levels:

Level 1: Calculating the performance level

The necessary PL_r was already determined during the design phase. Now for every safety function, a check is performed to determine whether the required PL is actually achieved with the selected components.

This can be performed with supporting tools such as the Safety Calculator PAScal, for example.

Level 2: Safety-related check

All components are checked for proper implementation on the complete robot cell. The goal is uncovering any faults during the installation, programming and commissioning. The check of robot systems in particular is a real challenge due to their high degrees of freedom. Not only must the robots be validated, but also every other periphery device in the application.

Level 3: Overrun measurement

If optical safeguards were installed in the system, a check must be performed as to whether they were installed in conformity with EN ISO 13855. This is carried out with a calibrated and certified overrun measurement device and, if the test is passed, confirmed with a quality seal on the optical safeguard. The time for the next inspection should also be clearly legible on the quality seal.

Level 4: Examination of the collision

HRC applications that already follow method 4 – as mentioned earlier – with which a collision between humans and robots is possible, must maintain the biomechanical limit values from ISO/TS 15066.

Compliance with the biomechanical limit values is absolutely necessary, irrespective of whether it is an inherently safe robot system or a robot system with reduced force/power.

ISO/TS 15066 gives instructions on the mathematical design of a collaborative robot system. This is only a theoretical approach, however. This approach only considers the transient contact. There is no mathematical solution for the quasi-static contact. A practical verification of the collision values that actually occur is thus absolutely necessary.

During the examination of the collision, all possible collision scenarios are checked in real-life situations. Every body area is simulated here using the information available in ISO/TS 15066. With a collision measurement device developed specially for this, the characteristic values of the collision are recorded.

▶ 3.6 Industrial robot, human-robot collaboration (HRC)

3.6.5 Purpose of the measurement

In principle, all robot movements can be hazardous! The human must therefore be protected against the robot. To protect the worker, the practice was previously strict segregation of man and machine. The robot remained enclosed in a cell while it performed its tasks.

Thanks to a new generation of robots and technologies, these days a safety fence may no longer be necessary if the collision is no longer hazardous.

In a robot application in which man and machine share the workspace and there is no safety fence to ensure safety, the person responsible for the CE marking process is responsible for compliance with the limit values.

The robot system cannot do this itself! It does not take into account dynamics.

In robot systems with reduced force/power, limit values are to be entered in the safety-related part of the control system; these are intended to make the collision safe. These values are not to be considered absolute, however.

What happens in reality?

- 1 If the collision occurs, the robot first “feels” resistance. The force of the robot is initially below the specified force limit. The robot now attempts to maintain its path and will increase the power of the drives.
- 2 The counterforce increases and the robot reaches the set force limit for the collision.
- 3 It is only at this point that the robot begins to stop its movement. The stopping distance occurs after the collision, therefore inside the human body.

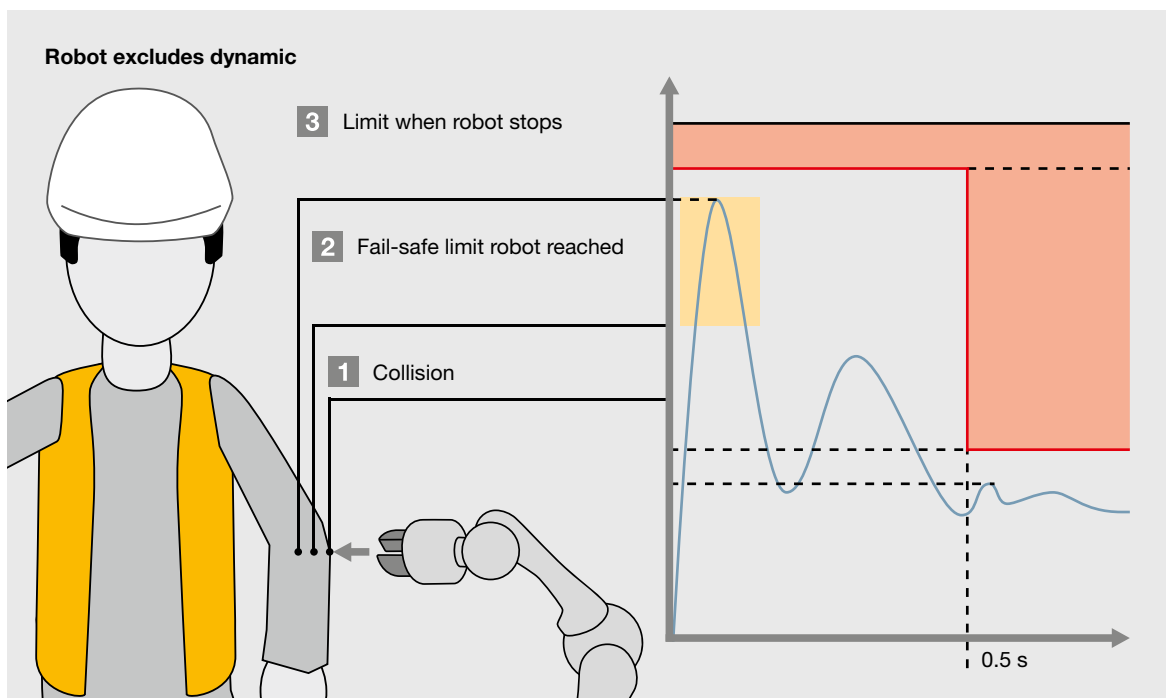

Pay attention to HRC method 4

▶ 3.6 Industrial robot, human-robot collaboration (HRC)



HRC collision measurement set for standard-compliant human-robot collaboration

The topics of overrun and reaction times must be taken into account, even with lightweight robots. In reality, multiples of the set collision values are often reached.

A reduction of the robot's dynamics is often the only remedy.

Checking the collision values using technical measurement is essential in order to still be able to submit the declaration of conformity in good faith.

It is important that such measurement types, and any other measurement techniques, are understandable, transparent and reproducible.

That's why Pilz developed the collision measuring device PROBmdf for this specific force and pressure measurement. Equipped with springs and corresponding sensors, the device measures the forces exerted on the human body precisely and compares them with the limit values. The measuring device is installed at the positions determined in the risk assessment, between the robot arm and a rigid,

inflexible surface. This simulates a quasi-static contact, e.g. the worker being crushed between the robot and plant. Measurement is started via software and the data is then processed and documented.

It is advisable to carry out the test up to ten times, depending on the measuring point. The highest value, i.e. the "worst case", is used for the validation. If the limit values are exceeded, additional safety measures must be installed, such as a light grid or guard.

The collision measuring device forms part of the complete Pilz set for validation in accordance with ISO/TS 15066. In addition to the measuring device with films and scanners, the set also contains various springs, which can be used to simulate the various body areas. Pilz provides the set, including training, maintenance, calibration and regular updates, on a rental basis.

▶ 3.7 Safe programming in accordance with EN ISO 13849-1

The installed hardware is perfect for taking on the majority of the safety technology and the requirements placed on this.

Users proceed here in accordance with EN ISO 13849-1 and use the B_{10D} values specified by the manufacturers, the $MTTF_D$ values or the PFH_D values to determine the performance level of the safety function. (Note: the architecture, diagnostic coverage etc. are also required.) The fact that increasingly more programmable systems (control systems) are being used for the implementation of safety functions is often overlooked here. As the application programs (SRASW) for these control systems now also influence the quality of the safety function, corresponding methods and procedures must now also be defined and applied for the software engineering; engineering because there is more to do than just the actual programming (coding).

There is a common saying: “There is no such thing as bug-free software!” No matter how carefully and painstakingly you program, errors in the programming code cannot be avoided. On average, 1,000 lines of code is expected to contain two errors.

A deadly example of a software error is “Therac-25”. A software error in that case resulted in a device for providing radiation therapy for cancerous tumours giving overdoses of radiation, leading to three casualties in three years (<https://en.wikipedia.org/wiki/Therac-25>).

What are typical software errors? Below are examples of software errors, also called programming errors or bugs:

- ▶ Syntax error: violation of grammatical rules
- ▶ Semantic errors: e.g. mixing up the command code
- ▶ Runtime error: e.g. continuous loop
- ▶ Logical errors: e.g. incorrect method of resolution
- ▶ Design error: e.g. error in the requirements definition
- ▶ Operating error: e.g. confusing operating concept.

3.7.1 Safety-related software

Safety controllers – e.g. the PSS 4000 – contain two types of software, referred to as safety-related software. There is a differentiation between whether the software is developed by the manufacturer for the function of the safety controller or whether it is a user-developed software. Software developed by the manufacturer is also called firmware or the operating system. In the normative parlance from EN ISO 13849-1, this is called safety-related embedded software, or SRESW. Software developed by the user of the safety controller, also referred to as an application program, is referred to as safety-related application software (SRASW).

Furthermore, there is a differentiation between two types of programming languages for the creation of this application software (SRASW) in EN ISO 13849-1.

Programming languages with unlimited or full language scope are called FVL (Full Variability Language). Typical examples of these FVL languages are C or C++. The area of application for these languages also includes the creation of SRESW, for example.

► 3.7 Safe programming in accordance with EN ISO 13849-1

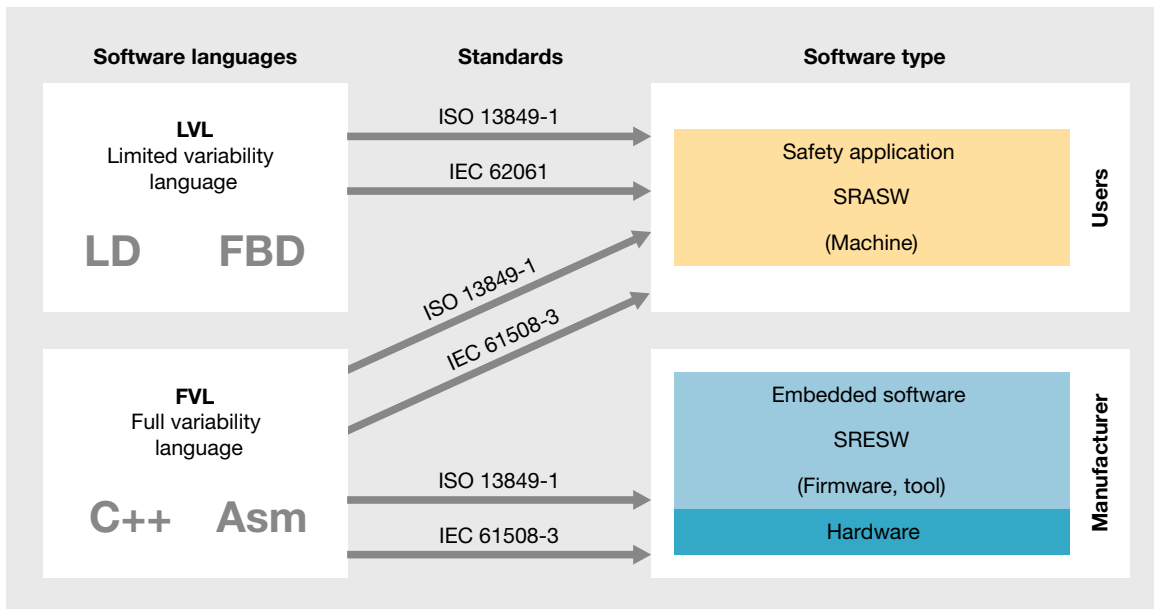

Programming languages with a limited language or function scope, on the other hand, are called LVL (Limited Variability Language). These languages are mainly used in the creation of SRASW. These languages are characterised by the ability to combine previously developed library elements with new application code and thus comply with the required specification for the safety function. Classic examples of LVL are PLC languages such as Ladder Diagram or Function Block. With the automation system PSS 4000, it is also possible to use the programming language Structured Text as an LVL. Increasingly more controller manufacturers limit the function of high-level languages like C or C++ to such an extent that these could also be considered LVL.

The creation of safety-related embedded software is not discussed in further detail. The use of FVL during the development of SRASW is also discouraged, as the probability of a systematic programming error increases with the use of these programming languages.

3.7.2 Software in relation to the risk assessment

If a safety-related protective measure has been defined as part of the risk assessment based on EN ISO 12100, there is an increase in use of safety controllers or automation systems with integrated safety functions. As already discussed, not only the classification of the safety controller as a hardware component in a performance level is crucial here, but rather the engineering of the safety-related application software also affects the quality of the safety function. Based on the required performance level in accordance with EN ISO 13849-1, the safety-related application software must also conform to the performance level.

If for example the safety function requires a performance level of PL d, the SRASW must at least correspond to the measures for achieving the performance level PL d. In the reverse case, it is possible that despite development of an SRASW in accordance with the requirements of performance level PL e, the entire safety controller ultimately only achieves performance level PL c when using hardware with PL c.

▶ 3.7 Safe programming in accordance with EN ISO 13849-1

3.7.3 Basic requirements for software development

In Section 4.6.3 of EN ISO 1384-1, the requirements placed on the creation of an SRASW are explored in more detail. Requirements are placed on the development tools and the development process here in addition to the requirements for the software to be developed.

General requirements for the SRASW that is used in a safety function with a performance level from a to e include:

- ▶ Development lifecycle with verification and validation
- ▶ Documentation of specification and design
- ▶ Modular and structured programming
- ▶ Functional tests
- ▶ Suitable development activities after modifications

The development lifecycle of safety-related software can also be described using the simplified V model. The left branch of the V model describes the design-related development stages for the creation of the software. Here each development stage is verified (checked) compared to the result of the previous work stage. The right branch of the V model describes the activities when performing

the check, also called verification and validation. The model also explains that each design-related development stage is accompanied by a verification or validation stage, while the test plan required for the test should already develop parallel to and independently of the development stage.

The consistent application of the V model – using error-preventing measures should result in the engineering/development of software with as few errors as possible. Software that is categorised by properties such as readable, understandable, testable and serviceable – overriding requirements for safety-relevant software according to EN ISO 13849-1. Modular, structured program creation should naturally also be guaranteed as a result. A good option for the programming of SRASW is referring back to software modules/blocks already certified by the manufacturer.

In reality, changes frequently interrupt the development, which is natural. These must routinely be taken into account during development and their effects must be evaluated (impact analysis). All of these activities should also be performed in accordance with the V model and recorded using a change history. It is of course mandatory to document all activities in the development process in any case.

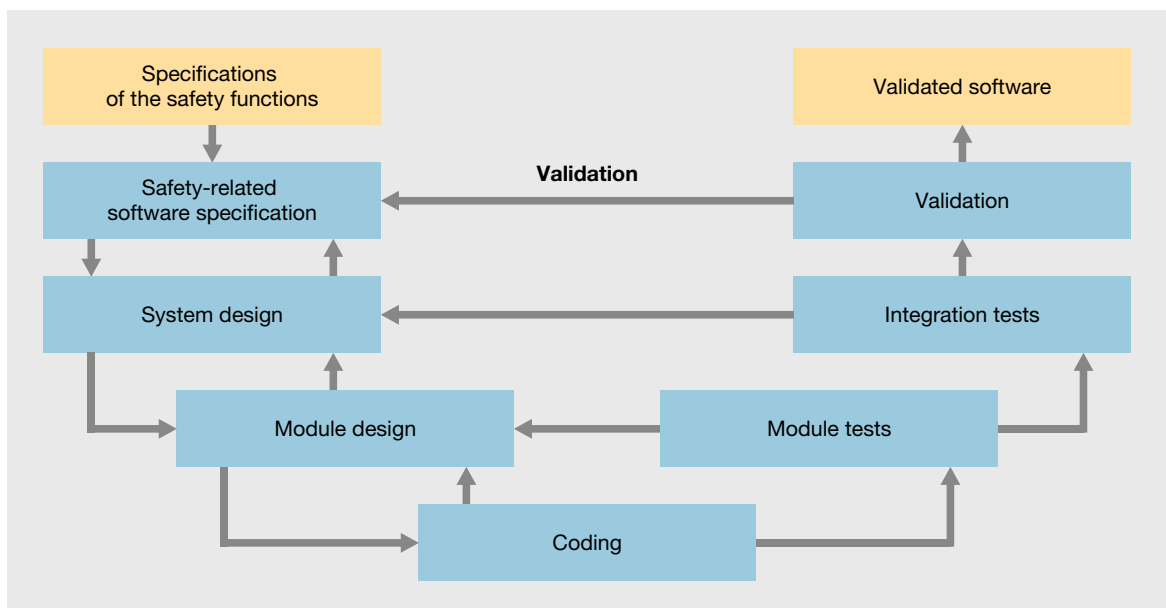

▶ 3.7 Safe programming in accordance with EN ISO 13849-1

3.7.4 Additional fault-prevention measures for increasing performance level

As already described, basic measures are necessary for achieving a performance level PL a to e. As the performance level increases from PL c to e, additional fault-prevention measures must additionally be introduced. The specifications of the SRASW must be checked and the people involved in the lifecycle must be provided with precise information on the safety functions, the performance criteria and the control architecture as well as the detection and handling of external failures.

Furthermore, particular attention must be paid to selection of tools.

3.7.5 Programming tools, languages and libraries

Tools in this sense are understood as the selection of programming tools, libraries and languages.

Programming tools should have the ability to avoid systematic errors, such as:

- ▶ Incompatibility of data type
- ▶ Incomplete calling of interfaces
- ▶ Recursions
- ▶ ...

The check should already be performed during compilation and not wait until the runtime of the software.

Furthermore, the programming tools should be suitable for the application of a modular programming procedure and also use a recognised subset of the IEC-61131-3 languages. Graphical languages such as Ladder Diagram or Function Block are often more easily readable and more understandable than purely text-based languages. This is why the use of graphical programming languages is recommended.

The programming tool PAS4000, which is part of the automation system PSS 4000, not only offers textual programming languages such as Instruction List and Structured Text, but also the graphical programming languages Ladder Diagram and Pilz's own graphical programming language PASmulti.

PNOZmulti graphical programming is part of the PNOZmulti range.

Validated function block libraries should be referred to whenever possible. The manufacturers of safety systems offer a number of already validated and certified function blocks in the libraries of their programming tools. Another option is referring back to application-specific function block libraries that have been developed and documented during projects and are based on the requirements for SRASW development in accordance with EN ISO 13849-1.

3.7.6 Structuring and modularity of the software

Clean structuring and modularly designed software form the basis for fault prevention and for handling changes. Attention must be paid to this as early as the specification and design phases of the software and this procedure is to be supported through the use of already validated library function blocks. For independently developed blocks, semi-formal procedures (graphical methods) should also be applied to describe the data or the control flow. Methods such as status diagrams and program flow charts are particularly suitable for this. The function blocks to be developed should also be programmed with a minimised code length and this should then be carried out with entry and exit.

▶ 3.7 Safe programming in accordance with EN ISO 13849-1

Architecture in three levels has really proven itself:



- ▶ Inputs: recording information and signals of the safety sensors through safety inputs
- ▶ Processing: processing of the information to implement the safety function that leads to a safe condition
- ▶ Outputs: actuation of the operator elements through safety outputs

With the actuation of safety outputs, it is essential that these are only used in one program section. Non-compliance with these normative requirements here in particular can lead to hazardous conditions at plant and machinery level. In general, the programmer of SRASW should employ a defensive programming style. Defensive programming aims to create software that detects abnormal processes, data and values (within the program) during runtime and reacts to these in a pre-determined way.

This can be achieved, for example, through:

- ▶ Range checking of variables
- ▶ The plausibility test of values
- ▶ Avoidance of set and reset commands
- ▶ Grouping and structuring of the software

3.7.7 SRASW and non-SRASW in a component

Modern automation systems such as the PSS 4000 combine safety-related programming with non-safety-related programming. With this type of controllers in particular, or during the creation of the software for this type of automation systems, these software components must be implemented in different function blocks and with a defined interface. It is of particular importance that no logical link between safety-related and non-safety-related data is created that results in a reduction of the integrity of the safety-related signals, e.g. through an OR link of these signals.

3.7.8 Software implementation and coding

The requirement from EN ISO 13849-1 is that the code must be readable, understandable and testable. It is therefore important to define clear programming guidelines in the organisation. Every programmer should be able to understand and apply these guidelines. Programming guidelines (coding rules) may contain, for example, the syntax of variables, as one of the normative requirements states that the use of hardware addresses (e.g. E1.0) is to be avoided and instead a symbolic variable (e.g. Input_EStop_Channel 1) is to be used.

If possible, the created code (application program) should be verified using a simulation as well as a control and data flow analysis (for PL d and e).

▶ 3.7 Safe programming in accordance with EN ISO 13849-1

3.7.9 Testing

A time-intensive test phase often follows the coding of the software. As already discussed, errors may occur when creating the SRASW despite all measures to prevent errors. These errors should be discovered during the test phases wherever possible. To be able to adequately perform this test phase, detailed test planning should already be started at the same time as the specification phases. All test cases with completion conditions and the tools used for the test should be listed in this.

The black-box test of the functional behaviour and the performance criteria make up an adequate validation method. The black-box test refers to a method with which the test criteria are developed and then performed without knowledge of the inner workings of the test object. For PL d and PL e software, a test case run based on limit value analyses is recommended in which the system is deliberately tested beyond its intended application. As an example, a parameter could be exposed to a higher value than its specified limit value. Before starting the black-box testing, however, an I/O test should be used to ensure that the safety-related signals used are also used correctly in the SRASW.

PL/Category	Check measures in accordance with EN ISO 13849-2
all PL _r	Black-box test of the functional behaviour and the performance, e.g. time characteristic
recommended for PL _r d or e	Additionally expanded test cases based on limit value analyses
all PL _r	I/O tests to ensure that the safety-related input and output signals are used correctly
PL _r and categories with fault detection	Test cases that simulate faults that are determined analytically beforehand, together with the expected reaction in order to assess the suitability of the software-based measures for fault control

▶ 3.7 Safe programming in accordance with EN ISO 13849-1

3.7.10 Documentation

In addition to the result of an executable code, all activities must be documented during the development lifecycle. If changes to the SRASW are subsequently performed, these must also be documented. The principle that this must be complete, available, readable and understandable also applies to the documentation. Function blocks must be documented within the code as well in accordance with these requirements. There is also the demand that every function block contains a module head, which must contain information such as function description, I/O description, version and specification of a legal person. Furthermore, sufficient commenting on the code and the declaration lines is to be provided.

3.7.11 Verification

The verification often employs a code review method known as the “four eyes” principle. The four eyes principle means that the person who created the documents or the code does not check these, but rather that this is performed by another competent person.

3.7.12 Configuration management

Configuration management is recommended for companies that create SRASW. This means that all relevant documents, software modules, test results and tool configurations that were created with respect to the creation of the SRASW must be identified and archived.

3.7.13 Changes

With every change to the SRASW, a check must be performed to determine to what extent this change impacts the safety and the requirements from EN ISO 13849-1 for the creation of software. This means that even with a change to an SRASW, the V model as well as the normative specifications and methods must be applied. Furthermore, the change must be clearly and adequately documented.

3.7.14 Summary

All design engineers, developers, programmers for safety-related software should follow a systematic approach to the development of SRASW and not just limit themselves to the selection of the appropriate components (hardware). Software and the errors it possibly contains play an important part in safety quality and should therefore be given the same weight as the correct selection of hardware components.

There must also be the awareness that the measures described here cannot be developed and applied without effort.

▶ 3.8 Validation

Validation (from lat. validus: strong, powerful, healthy) describes the testing of a plan or solution approach with regard to the task it is intended to fulfil and the associated solution to a problem. Verification describes the procedure for testing a plan or solution approach with regard to a corresponding specification. Together, both processes are used to demonstrate the suitability of a specific solution approach.

In mechanical engineering, a validation process must provide evidence that the plant or machine meets the requirements of its specific intended use. The process of verification also examines the functionality of the technical equipment and the safety-related parts of control systems, thereby confirming that they fulfil their functions safely, in accordance with the specification. Documentation of the results and solutions from the verification and validation process ensures that the intended target has actually been achieved.

The harmonised standard EN ISO 12100 – with its basic terminology, general design principles, procedures for assessing the risks (analysis and estimation) as well as the principles for risk assessment and risk reduction – defines key procedures for safety-related systems or safety-related parts of machine and plant control systems. Other harmonised standards use this essential standard as a basis for describing the design, structure and integration of safety-related parts of control systems and safeguards: standards such as EN ISO 13849-1/-2 and EN 61508 with its sector standard EN 62061 (the origin of validation). In contrast to EN 62061, EN ISO 13849-1/-2 is not restricted to electrical systems but can also be applied to mechanical, pneumatic and hydraulic systems. Both standards (EN ISO 13849-1/-2 and EN 62061) specify essential requirements for the design and implementation of safety-related control systems on machinery and are successors to EN 954-1, which is no longer valid. In the application of EN ISO 13849-1 or EN 62061, there are a number of differences in the design and implementation of safety-related parts of control systems and their subsequent assessment within the validation process.

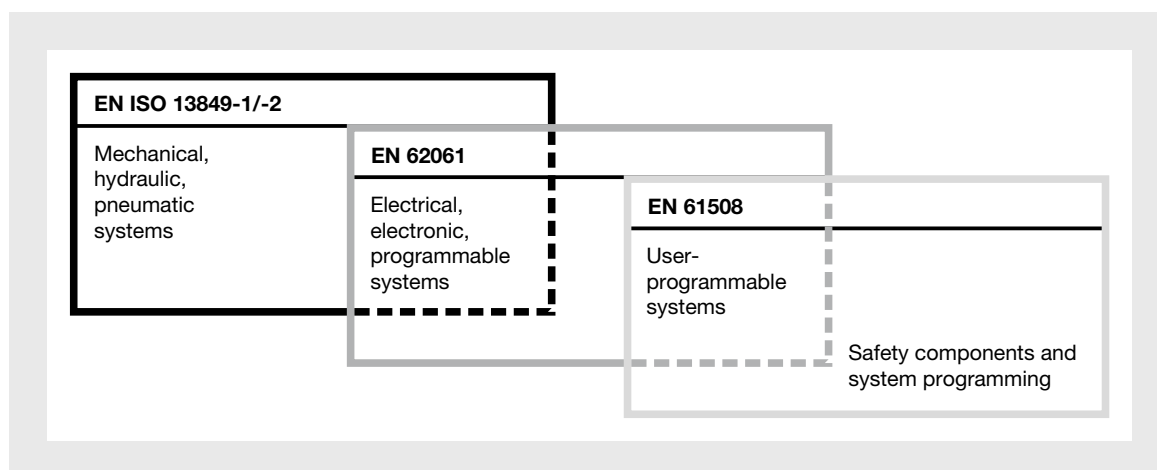

Structure and overlap of generic and sector standards

▶ 3.8 Validation

3.8.1 Verification of safety functions in accordance with EN ISO 13849-1/2

Required characteristic data: PL, (control) category, $MTTF_d$, DC, CCF, $B10_d$

The stipulated requirements form the basis for the design for implementation of the safety function (selection of components and architecture). The planned components are grouped into subsystems and the achievable performance level (PL) is defined. Verification of the planned safety function: achieved $PL \geq PL_r$. The validation process confirms the conformity of the configuration and function of the safety-related parts of control systems within the overall specification and on the plant and machinery. Note: guidance on how to implement a validation process and validation tools for various technical systems can be found in EN ISO 13849-2.

3.8.2 Verification of safety functions in accordance with EN 62061

Required characteristic data: PFH, SIL, $MTTF_d$, DC, CCF, $B10_d$. The implementation of safety functions is designed on the basis of the formulated requirements. This involves the selection of appropriate components and the development of a coherent architecture. The planned components are grouped into subsystems and are the basis for determining the safety integrity level (SIL). Verification of the planned safety function: achieved $SIL \geq$ required SIL.

PL (EN ISO 13849-1)	SIL (EN 62061)
a	-
b	1
c	1
d	2
e	3
-	4

Comparison chart performance level (PL) and safety integrity level (SIL)

The verification of safety-related parts of control systems must demonstrate that the requirements and specifications have been met in accordance with the applied standard and the safety-related specification. These requirements refer specifically to

- ▶ the properties of a safety function, as defined in accordance with the risk assessment and safety concept/design,
- ▶ the standard-compliant architecture of the category defined for the safety function.

Verification of the safety-related parts of control systems consists of a thorough analysis and, if necessary, the carrying out of additional (function) tests and fault simulations. It is advisable to start the analysis right at the beginning of the design process so that any faults and/or problems can be identified early and dealt with accordingly.

The way in which the analysis and tests are carried out will depend on the size and complexity of the control system and the way it is integrated within the plant or machine. It makes sense, therefore, to carry out certain analyses and tests only once the control system has been developed to a certain level. An independent person or body should be commissioned to ensure that the analysis is independent. To carry out the validation, a validation plan must first be produced to establish the scope of the analysis and tests. The exact scope and balance between the two processes always depends on the technology that is used and its complexity. The diagram overleaf provides a schematic overview of the validation process.

► 3.8 Validation

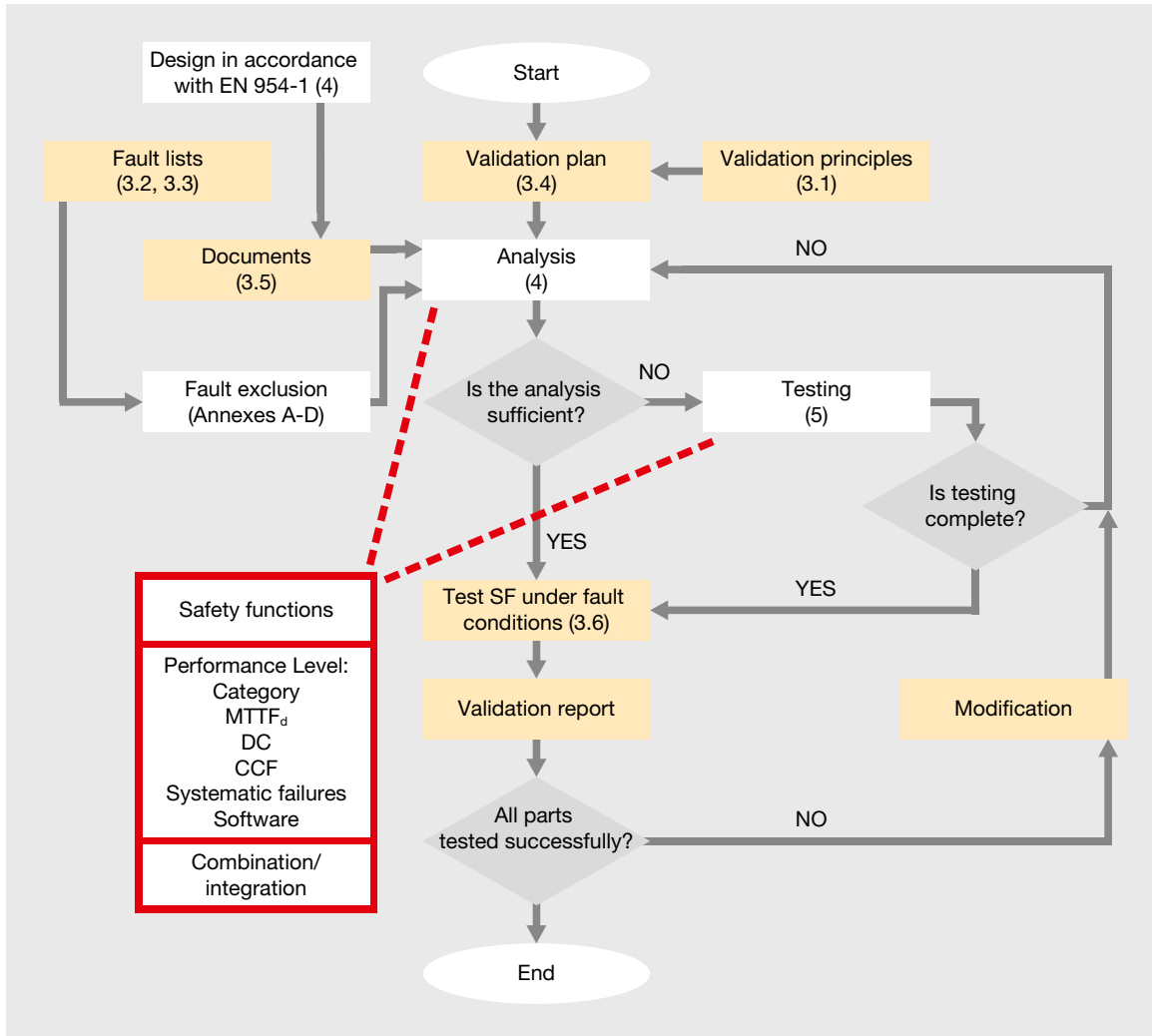

Validation plan in accordance with EN ISO 13849-2

3.8.3 General information about the validation plan

The validation plan must describe all the requirements for carrying out the validation of the specified safety functions and their categories. The validation plan must also provide information about the means to be employed to carry out the validation. Depending on the complexity of the control system or machine that is to be tested, the validation plan must provide information about:

- ▶ the requirements for carrying out the validation plan
- ▶ the operational and environmental conditions
- ▶ the basic and well-tried safety principles
- ▶ the well-tried components
- ▶ the fault assumptions and fault exclusions
- ▶ the analyses and tests to be applied

The validation plan also contains all of the validation documents.

▶ 3.8 Validation

3.8.4 Validation by analysis

The validation of safety-related parts of control systems is primarily carried out by analysis. Evidence must be provided to show that all the properties required by a safety function (SRCF) are actually present. The following factors are included in the analysis:

- ▶ the hazards identified in association with the machine
- ▶ the reliability
- ▶ the system structure
- ▶ the non-quantifiable, qualitative aspects which affect system behaviour
- ▶ deterministic arguments such as empirical values, quality features and failure rates

“Top-down”/“Bottom-up” analysis techniques

There are two different techniques to choose from when selecting the analysis technique: the deductive “top-down” technique and the inductive “bottom-up” technique. The deductive “top-down” technique can be applied in the form of a fault tree analysis or event tree analysis. Examples of the inductive “bottom-up” technique are the failure modes and effects analysis (FMEA) and failure modes, effects and criticality analyses (FMECA).

3.8.5 Validation by testing

When validation by analysis is not sufficient, further tests will be needed to complete the validation. As many control systems and their requirements are extremely complex, further tests need to be carried out in the majority of cases.

In practice the test requires a test plan, which must include the following:

- ▶ the test specifications
- ▶ the expected results
- ▶ the chronology of the individual tests

The test results must be documented in a way that is traceable; the test record must include the following as a minimum:

- ▶ the name of the person and/or body undertaking the test
- ▶ the environmental conditions at the time of the test
- ▶ the test procedures and equipment used

To demonstrate that the target and defined safety objective has actually been achieved, the test results are then compared with the specifications from the test plan.

3.8.6 Verification of safety functions

An important part of validation is verification that the safety functions comply with the intended specifications, functions, categories and architectures. It is important to validate the specified safety functions in all of the plant/machine’s operating modes. Alongside the basic validation of each safety function, the validation of the PL and/or SIL value within the safety function also has a key role to play. The following steps are required when verifying the safety function that a PL has achieved:

- ▶ Validation of the category
- ▶ Validation of the $MTTF_d$ values
- ▶ Validation of the DC values
- ▶ Validation of the measures against common cause failures/CCF
- ▶ Validation of the measures against systematic faults

▶ 3.8 Validation

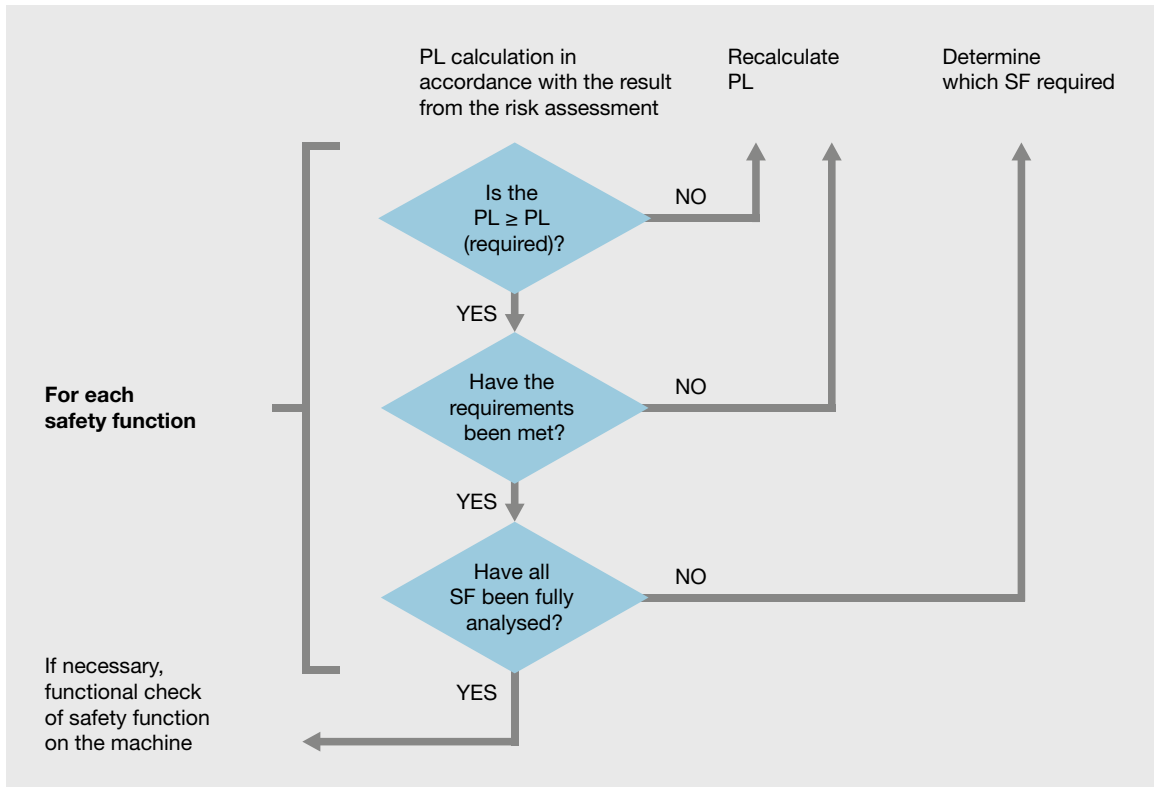

Verification and validation flowchart (source: Pilz training materials)

The validation of safety functions is a really complex process and so it is advisable in this case to use a software tool (e.g. PAScal), which can help you to calculate the planned and/or implemented safety functions. Based on the safety-related characteristic values of the planned or employed components, these calculation tools validate the values that have been achieved, including the required or demanded default values PL_r or SIL. The advantage of software-based tools is that they guide you step-by-step through the individual stages involved in validating safety functions. The option within the tool for graphic modelling of safety functions gives the tester additional security in his calculations and helps to make the results more traceable.

▶ 3.8 Validation

3.8.7 Validation of software

The provisions in the standards EN 62061 and EN ISO 13849-1/-2 allow the development of safety-related software in the machine sector for all performance levels and safety integrity levels. As a result, software assumes a high level of responsibility and largely determines the quality of the safety function to be implemented. It is therefore of the utmost importance that the software created is clear, legible and can be tested and maintained. To guarantee the quality of the software, it is also subjected to a validation process during development. The basic principles are:

- ▶ Working to a V model (development lifecycle incl. verification and validation)
- ▶ Documentation of specification and design
- ▶ Modular and structured programming
- ▶ Functional testing
- ▶ Appropriate development activities after modifications or adjustments

A corresponding report is also produced in this case, to confirm that the software conforms to the safety requirement specification; this report forms part of the validation report for the plant or machine. As with the validation of the safety functions, the software should not be validated by the programmer himself but by an independent person.

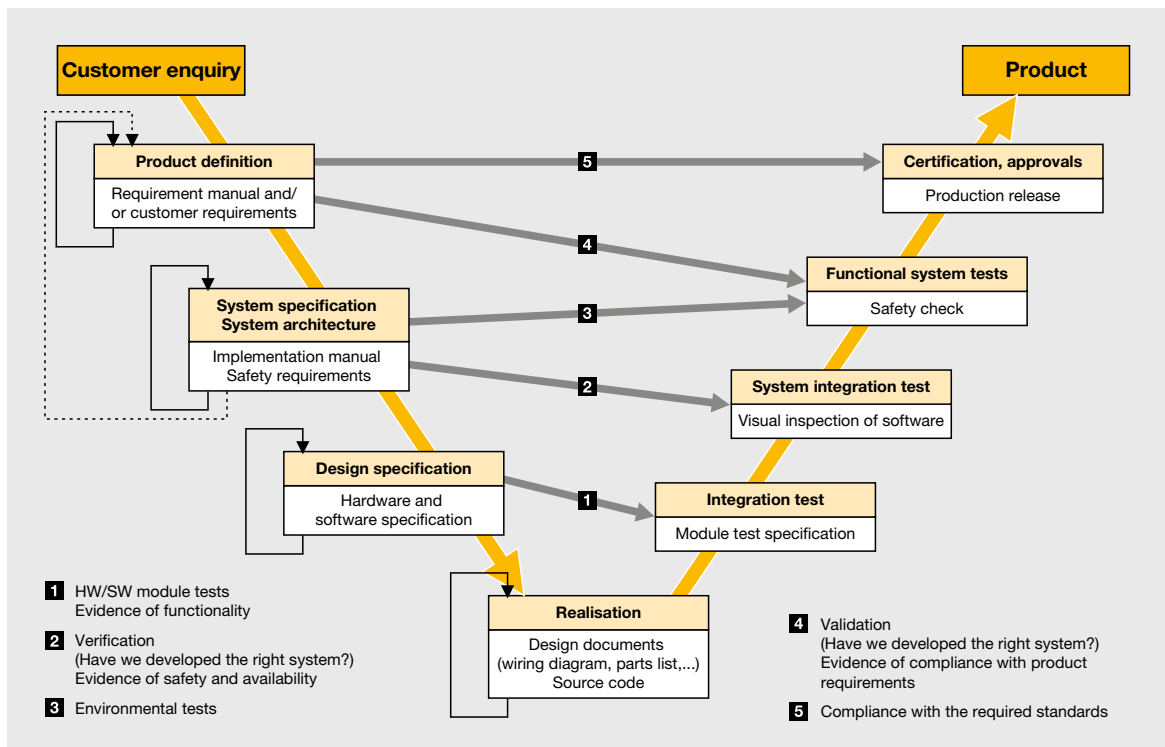

Pilz GmbH & Co. KG's V model for engineering projects

▶ 3.8 Validation

Today there are some very good certified software tools available to develop and program safety-related software for the relevant safety control system. The use of software tools simplifies the whole validation process, as the blocks contained within the software are essentially pre-certified and at the same time validated. The more these software blocks are used within an application, the less validation work will be needed. The same is true when using parametrisable user software; this also contains pre-validated blocks. The subsequent series of function tests must demonstrate whether the safety functions operate in accordance with their specification. This includes simulation of anticipated faults.

3.8.8 Validation of resistance to environmental requirements

When determining the performance of safety-related parts of control systems, environmental conditions such as the environmental site and the way in which the control system will subsequently be used play an important role in respect of the system. Relevant key words include waterproofing and vibration protection. The system must therefore be validated by analysis. In specific terms, the analysis must show that the control system or system has the mechanical durability to withstand the wide range of stresses from environmental influences such as shock, vibration and ingress of contaminants. Safety-related parts of control systems must maintain a safe condition under all circumstances. The analysis should also consider factors such as temperature, humidity and electromagnetic compatibility.

3.8.9 Production of validation report

Finally, after all the verification and validation steps have been carried out, the validation report is produced. This contains all the information about the analyses and tests that have been carried out in traceable form, for both the hardware and software. Cross-references to other documents are permitted provided these are traceable and identifiable. Any safety-related parts of control systems which have failed the validation process should be named, along with the factors that led to their exclusion.

3.8.10 Conclusion

Maintenance and repair/periodic tests

Naturally, the ravages of time also gnaw away at the performance of safety-related control systems. Wear and tear, corrosion and sustained (mechanical) stresses lead to a reduction in safety; in an extreme case they can even lead to dangerous failures of control components, even the whole control system. For this reason, it is necessary to maintain the safety-related parts of control systems at regular intervals and to carry out periodic tests to check functional safety. A maintenance and repair plan should be available in written form along with records from the periodic tests. The function tests must be carried out by a competent person. Based on the hazard assessment in accordance with §3 of the Ordinance on Industrial Safety, the machine or plant operator should define the type, scope and frequency of the periodic tests. Details of the Ordinance on Industrial Safety and more information on our services can be found at www.pilz.com.

▶ 3.8 Validation

3.8.11 Appendix

The topic therefore centres around basic, well-validated safety principles and safety components, as well as fault exclusions. The following lists correspond to the specifications of EN ISO 13849-1 and EN ISO 13849-2 and provide a brief overview of the safety-related considerations.

Basic safety principles in accordance with EN ISO 13849-1/EN ISO 13849-2

Features of basic safety principles may be:

- ▶ Use of suitable materials and manufacturing methods, taking into account strength, durability, elasticity and wear
- ▶ Correct dimensioning and shaping, taking into account stresses and strains
- ▶ Pressure limiting measures such as pressure control valves and chokes
- ▶ Speed limiting measures

Annexes A–D of EN ISO 13849-2 contain a list of the basic safety principles affecting mechanical, hydraulic, pneumatic and electrical/electronic systems.

Well-validated safety principles in accordance with EN ISO 13849-1/EN ISO 13849-2

Features of well-validated safety principles are, for example:

- ▶ Avoiding faults, e.g. through the safe position of moving parts of components
- ▶ Reducing the probability of error, e.g. by over-dimensioning components
- ▶ Defining the failure mode, e.g. through positive electrical separation/positive opening contacts
- ▶ Reducing the effect of failures, e.g. by multiplying parts

Annexes A–D of EN ISO 13849-2 contain a list of the well-validated safety principles for mechanical, hydraulic, pneumatic and electrical/electronic systems.

Well-validated components in accordance with EN ISO 13849-1/EN ISO 13849-2

A component can be regarded as well-validated when it has been

- ▶ used in the past with successful results in a number of applications,
- ▶ made using principles which document the suitability and reliability of the component.

A list of the well-validated components for mechanical systems, such as screws, springs and cams, as well as components for electrical systems, such as contactors and relays can be found in Annexes A–D of EN ISO 13849-2.

There are currently no well-validated components listed for pneumatic and hydraulic systems.

Fault exclusions in accordance with EN ISO 13849-2

The requirements for applying a fault exclusion must be indicated in the validation plan. It is important that each fault exclusion can be justified with a reasonable, traceable explanation. Annexes A–D of EN ISO 13849-2 provide an overview of possible fault exclusions based on their fault assumptions. For example, these may be:

- ▶ Fracture due to over-dimensioning on mechanical systems
- ▶ Spontaneous change due to safety device on pneumatic systems
- ▶ Change of switching times due to positive action on hydraulic systems
- ▶ Short circuits between adjacent contacts insulated from each other on electrical/electronic systems

▶ 3.8 Validation

What can Pilz do for you?

Pilz GmbH & Co. KG offers a wide range of services, including validation within the lifecycle of the plant and machinery. By mirroring the risk assessment and the safety concept, the developed solutions are adapted to suit the actual requirements in the system integration. Validation by Pilz follows an objective and systematic review of the implemented measures, evaluation of the technical safeguards and finally function tests. Compliance with all applicable safety standards and directives is assured. With a wealth of experience in validating machinery, Pilz engineers have developed structured methods for inspecting safety-critical elements of plant and machinery. The calculation tool PAScal helps to verify the performance level that has been achieved for the respective safety function.

Validation by Pilz includes:

- ▶ Mirroring of the requirements from the risk assessment and safety concept
- ▶ Verification of the achieved performance level in accordance with EN ISO 13849-1/ EN IEC 62061, based on the calculation tool PAScal, Sistema etc.
- ▶ Verification of the operating manual
- ▶ Function testing and fault simulation (safety check)
- ▶ Testing of the safety-related software and hardware functions
- ▶ Testing of the sensor/actuator technology and its wiring
- ▶ Measurements (earth conductor, sound level etc.)
- ▶ Production of a test report with detailed information about the results
- ▶ Acceptance of responsibility as the “authorised representative” by signing the EC declaration of conformity

How you benefit from validation by Pilz

- ▶ Qualified methods during conformity assessment procedure
- ▶ Consideration of all relevant aspects of validation and CE marking
- ▶ Support by the safety experts at Pilz

Complete your overall safety process with CE marking

To complete your machine’s safety lifecycle, Pilz can offer CE marking as a final service. In this case, Pilz undertakes the whole conformity assessment process, assuming responsibility for the whole procedure. By signing as the authorised representative on the EC declaration of conformity, Pilz confirms that the requirements of the directives have been met. As a result you obtain the “passport” your machine needs throughout the European internal market.

Regular inspections and up-to-date knowledge of standards, directives and product developments are essential to anyone wishing to operate their plant or machine safely on a long term basis. In accordance with the Ordinance on Industrial Safety, it is essential that electrosensitive protective equipment (for example: light grids, light beam devices, scanners etc.) is properly configured and installed and undergoes regular inspection. Responsibility for this lies fully in the hands of the operator.

Regular inspections keep you on the safe side

An independent inspection body, accredited by DAkkS (German Accreditation Body) in accordance with DIN EN ISO 17020, guarantees objectivity, high availability for your plant and machine, plus the highest possible safety for your staff.

At the end of the process Pilz will submit the inspection report and discuss all the results with you. If the inspection is passed, the plant is given a Pilz quality seal.

▶ 3.9 Certification and accreditation

Customers are increasingly regarding certificates, or service providers with third-party certification, as a guarantee of quality. In principle, however, certificates are not legally binding and can be issued by practically anyone. They are merely an indication that a third-party has checked that certain work practices are carried out in accordance with the relevant specifications. The certificates actually say nothing about the quality of this third-party inspection. That's why it is important to have accurate knowledge about the competence of the certifying company or to make enquiries if necessary.

The situation is different with accredited companies: accreditations are legally binding and can only be issued by national bodies. With accreditation, the public accreditation body confirms that a company or institution possesses the competence to perform certain conformity assessment tasks. Conformity assessment is a procedure which checks whether certain specifications have been met, by definition or objective. If an accredited company or institution issues a certificate, the customer can assume that it has the necessary competence to do so.

3.9.1 Accreditation: Quality seal for customers

Accredited conformity assessment bodies, accredited bodies for short, are generally institutions such as test or calibration laboratories, inspection or certification bodies. They provide services such as tests, inspections, certifications, e.g. of management systems, persons and products, in order to assess the conformity of products, plants or management systems. The assessment is usually part of a test procedure that has to demonstrate that certain requirements, such as those listed in the standards, have been met.

In Europe, accreditation is uniformly regulated through the Accreditation Directive 765/2008/EC. Since 01.01.2010, all member states have been obliged to operate a single national accreditation body. This will accredit the conformity assessment bodies and evaluate them at regular intervals through audits, to guarantee continued compliance with the requirements. Among other things, the accreditation process checks the independence of the organisation, quality management, training of staff, management of calibrated measuring devices, work instructions and handling of records and test reports, to ensure they conform to the relevant EN/ISO standard. The national accreditation bodies will also examine and evaluate the practical implementation of the on-site certification tasks. Accreditation is beneficial to both the accredited institution and its customers in equal measure: it shows the customer that the institution is carrying out its work correctly and in accordance with the standards. At the same time, the customer obtains an assessment benchmark for the competence of the organisation performing the check.

Organisations generally work in isolation and rarely, if ever, receive an independent technical assessment of their performance. A regular assessment by an accreditation body examines all aspects of a facility's operations with regard to the continuous production of accurate and reliable data. The accreditation body identifies and discusses areas for improvement; at the end of the assessment, a detailed report is available. If required, the accreditation body can monitor subsequent activities. So the company can be sure that it has introduced appropriate corrective actions.

► 3.9 Certification and accreditation



Some examples of accreditation bodies in Europe

▶ 3.9 Certification and accreditation

In Germany the German Accreditation Body (Deutsche Akkreditierungsstelle GmbH* [DAkkS]), founded by the Federal Ministry of Economics and Industry, is responsible for this. All previous accreditation bodies (DACH, DAP, TGA/DATECH and DKD) were merged within DAkkS early in 2010.

* For Austria: bmwfi,
for Switzerland: Swiss Accreditation Service (Schweizerische Akkreditierungsstelle [SAS])

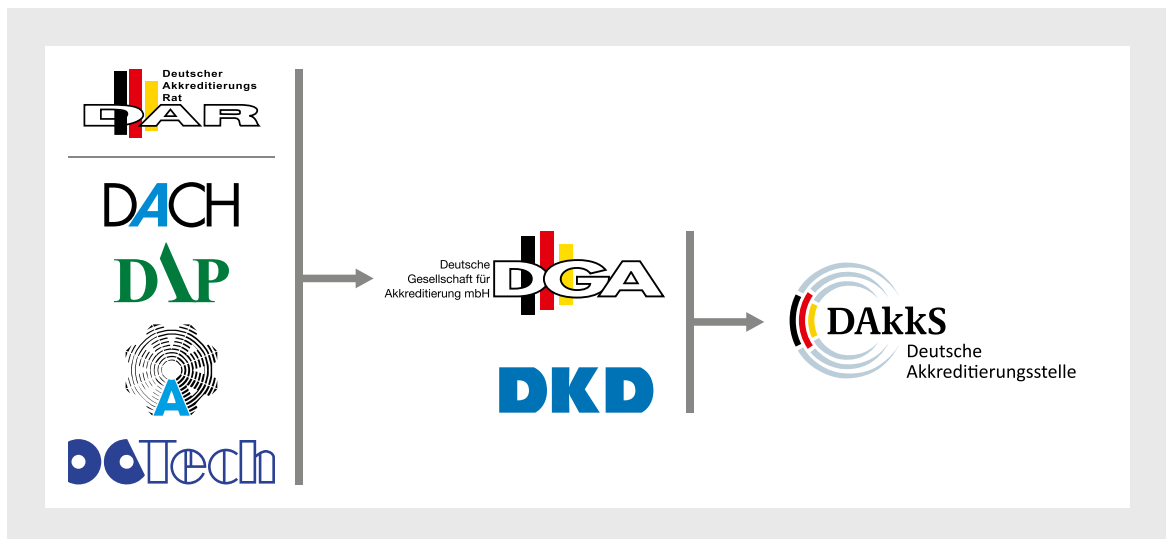

Merging the German accreditation bodies into DAkkS

Accreditation continues to enjoy worldwide recognition due to agreements between DAkkS and the International Laboratory Accreditation Cooperation (ILAC), the International Accreditation Forum (IAF) and the European co-operation for Accreditation (EA).



International recognition of DAkkS

MRA = Mutual Recognition Agreement

MLA = Multilateral Recognition Arrangement

▶ 3.9 Certification and accreditation

These agreements ensure that all accredited bodies worldwide have a standard level of competence and that the services that are carried out satisfy the very highest quality requirements. Both nationally and internationally, accreditation is highly regarded as an indicator of technical competence. Many industry sectors routinely specify accreditation for suppliers of testing services.

Unlike certification to ISO 9001, for example, accreditation uses criteria and procedures specifically developed to determine technical competence, thus assuring customers that the test, calibration or measurement data supplied by the laboratory or inspection service is accurate and reliable. Accredited bodies can be recognised by the symbol of the relevant accreditation body, which is usually found on test or calibration reports. A list of the accredited bodies in Germany is available at www.dakks.de.



Example of the DAkkS logo for the Pilz inspection body

3.9.2 Accreditation or certification

Accreditation uses criteria and procedures specifically developed to determine technical competence. Specialist technical assessors conduct a thorough evaluation of all factors in an organisation that affect the production of test or calibration data. The criteria are based on international standards such as ISO/IEC 17020, ISO/IEC 17025 or ISO 15189, which are used worldwide to evaluate accredited organisations. Accredited bodies use this standard specifically to assess factors relevant to technical competence, such as:

- ▶ Technical competence of staff
- ▶ Validity and appropriateness of test methods
- ▶ Traceability of measurements and calibrations to national standards
- ▶ Suitability, calibration and maintenance of test equipment
- ▶ Testing environment
- ▶ Sampling, handling and transportation of test items
- ▶ Quality assurance of test and calibration data

By this process, accreditation assures organisations and their customers that test and calibration data produced by their accredited body is accurate and reliable.



Certification, to the standard ISO 9001 for example, is widely used by manufacturing and service organisations. It demonstrates that products, services and procedures meet the required quality standards. The aim in certifying an organisation's quality management system to ISO 9001, for example, is to confirm that the management system conforms to this standard. Although laboratories and inspection bodies can be certified to ISO 9001, unlike accreditation, such certification makes no claim regarding technical competence.

► 3.9 Certification and accreditation

3.9.3 Tests in accordance with the Ordinance on Industrial Safety and accreditation

All European employers are legally obliged to provide employees with safe work equipment. In Germany, this has been regulated since October 2002 at the latest by the industrial safety regulations* (BetrSichV). This regulation is the mandatory implementation of the Work Equipment Directive 2009/104/EC, which was adopted by the EU back in 1989 and has since been revised.

* In Austria: Ordinance on Working Equipment; in Switzerland: Federal Act on Accident Insurance (AIA)

The employer is obliged to guarantee this requirement the first time the work equipment is put into use and through subsequent regular testing. He must determine the test intervals himself, taking account of statutory specifications. He must also ensure that these tests are only carried out by “competent persons”. Technical Rule for Occupational Safety 1203 defines the requirements placed on a “competent person”. Essentially the person must have professional training, a certain amount of professional experience, recent professional activity and regular relevant continuing training in the field to be inspected. The employer is free to decide which staff member will be named the “competent person”. He must merely be convinced of his competence and be able to prove this in court.

Alternatively a company can also outsource these tests to an external provider. However, this does not absolve it of the responsibility of checking the competence of the company that will conduct the tests. Unlike certified companies, accredited bodies prove particularly helpful in this regard, because only accreditation makes a legally binding statement about the competence of such bodies, thereby satisfying the burden of proof.

Pilz GmbH & Co. KG operates an accredited inspection body, which companies can appoint to undertake the testing of safeguards on plant and machinery. Due to accreditation, the services are recognised worldwide. The inspection body has access to qualified inspectors in Germany as well as other EU member states. As a result, Pilz can offer its services not only within the EU but worldwide. In 2015, the German Accreditation Body (DAkkS) renewed the accreditation. This shows that Pilz meets all the requirements of EN ISO/IEC 17020:2012 for a Type C inspection body in the mechanical engineering sector and is competent to carry out the predefined conformity assessment tasks. Pilz can even carry out very complex examinations. The inspection body offers the following services:



Example of implementation of the EU Work Equipment Directive

▶ 3.9 Certification and accreditation

- ▶ Inspection of electrosensitive protective equipment ESPE (light curtains, scanners, safe camera systems)
- ▶ Measurement of stopping performance to confirm the specified safety distances
- ▶ Inspection of additional safeguards (E-STOP, safety gates, 2-hand)
- ▶ Verification of compliance with the minimum specifications of the Ordinance on Industrial Safety
- ▶ Verification of compliance with the minimum requirements of the Machinery Directive (CE)

If the customer selects an accredited inspection body that meets his testing or measurement needs, he can be sure that the inspection body can provide accurate and reliable results.

The technical competence of an inspection body depends on factors such as:

- ▶ Qualifications, training, experience of staff
- ▶ The right equipment, correctly calibrated and maintained
- ▶ Appropriate quality assurance procedures
- ▶ Adequate test procedures
- ▶ Validated test methods
- ▶ Inspections based on national standards
- ▶ Precise recording procedure and report production
- ▶ Suitable test facilities

All these factors help to ensure that an accredited inspection body is technically competent and able to carry out the tests it offers.

3.9.4 Conclusion

Essentially, every company is free to have its work equipment inspected by its own staff or to appoint an external company to do the work. However, in every case, the person conducting the inspection must be competent to do the job. If a staff member is selected, the employer can normally assess his competence. If he opts for an external provider, he will have to rely on written evidence. Certificates are generally not sufficiently compelling; in the event of a legal dispute, they do not usually meet the formal requirements. In contrast, accreditations for the relevant services provide reliable, legal security.

Informative links:

- ▶ DAkkS: <http://www.dakks.de>
- ▶ EA: <http://www.european-accreditation.org>
- ▶ ILAC: <http://www.ilac.org>



4

Safeguards



▶ 4 Safeguards

4	Safeguards	
4.1	European Union standards, directives and laws relating to safeguards _____	4-3
4.1.1	Standards for guards _____	4-7
4.1.2	Standards for dimensioning of guards _____	4-7
4.1.3	Standards for the design of protective devices or electrosensitive protective equipment _____	4-7
4.2	Guards _____	4-8
4.2.1	Fixed guards _____	4-8
4.2.2	Movable guards _____	4-9
4.2.3	Further aspects on the design of safeguards _____	4-11
4.3	Protective devices _____	4-16
4.3.1	Active optoelectronic protective devices _____	4-16
4.3.2	Further important aspects in connection with electrosensitive protective equipment _____	4-18
4.3.3	Other sensor-based protective equipment _____	4-19
4.4	Manipulation of safeguards _____	4-22
4.4.1	Legal position _____	4-22
4.4.2	Conduct contrary to safety – What does that mean? _____	4-24
4.4.3	What can designers do? _____	4-26
4.4.4	User-friendly guards _____	4-27
4.4.5	Conclusion _____	4-29

► 4.1 European Union standards, directives and laws relating to safeguards

Safeguards are necessary to provide operators with as much protection as possible from hazards that may arise during machine operation. They are primarily fences or barriers, which make physical access to the machine difficult. However, sometimes it's neither possible nor sensible to select a fixed guard of this type. In this case, the decision will fall in favour of a control technology solution which shuts down part or all of the machine, should anyone approach a source of danger, or brings the machine to a safe status by another means. Should this type of hazard protection also prove unsuitable, or if potential hazards remain despite the application of these measures, then indicative safety technology is the final option: in this case, the residual dangers are indicated in the operating manual or on the machine itself.

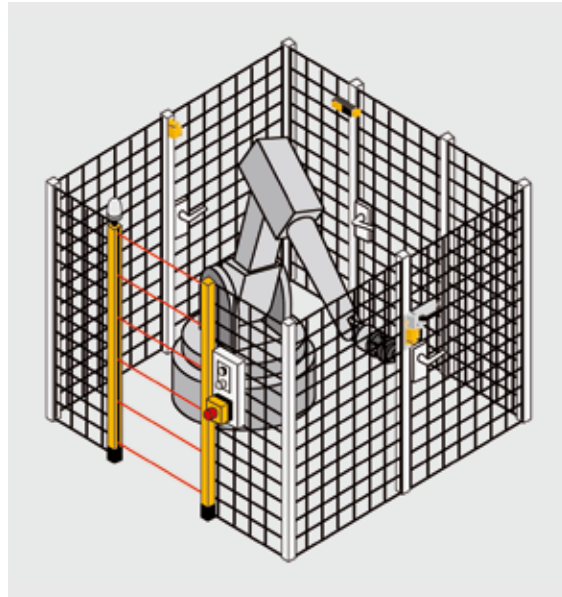

Guard barriers and safety devices protect against dangers

► 4.1 European Union standards, directives and laws relating to safeguards

There are a vast number of regulations that deal with safeguards on machinery. First of all, we'll consider the statutory regulations of European Directive 2006/42/EC.

Machinery Directive (2006/42/EC)

1.4. Required characteristics of guards and protection devices

1.4.1. General requirements

Guards and protective devices must:

- ▶ *be of robust construction*
- ▶ *be securely held in place*
- ▶ *not give rise to any additional hazard*
- ▶ *not be easy to by-pass or render non-operational*
- ▶ *be located at an adequate distance from the danger zone*
- ▶ *cause minimum obstruction to the view of the production process, and*
- ▶ *enable essential work to be carried out on the installation and/or replacement of tools and for maintenance purposes by restricting access exclusively to the area where the work has to be done, if possible without the guard having to be removed or the protective device having to be disabled.*
- ▶ *Guards must, where possible, protect against the ejection or falling of materials or objects and against emissions generated by the machinery.*

1.4.2. Special requirements for guards

1.4.2.1 Fixed guards

Fixed guards must be fixed using systems that can be opened or removed only with tools. Their fixing systems must remain attached to the guards or to the machinery when the guards are removed. Where possible, guards must be incapable of remaining in place without their fixings.

1.4.2.2 Interlocking movable guards

Interlocking movable guards must:

- ▶ *as far as possible remain attached to the machinery when open*
- ▶ *be designed and constructed in such a way that they can be adjusted only by means of an intentional action*

▶ 4.1 European Union standards, directives and laws relating to safeguards

Interlocking movable guards must be associated with an interlocking device that:

- ▶ *prevents the start of hazardous machinery functions until they are closed and gives a stop command whenever they are no longer closed*

Where it is possible for an operator to reach the danger zone before the risk due to the hazardous machinery functions has ceased, movable guards must be associated with a guard locking device in addition to an interlocking device that:

- ▶ *prevents the start of hazardous machinery functions until the guard is closed and locked, and*
- ▶ *keeps the guard closed and locked until the risk of injury from the hazardous machinery functions has ceased*

Interlocking movable guards must be designed in such a way that the absence or failure of one of their components prevents starting or stops the hazardous machinery functions.

1.4.2.3 Adjustable guards restricting access

Adjustable guards restricting access to those areas of the moving parts strictly necessary for the work must be:

- ▶ *adjustable manually or automatically, depending on the type of work involved, and*
- ▶ *readily adjustable without the use of tools*

1.4.3. Special requirements for protective devices

Protective devices must be designed and incorporated into the control system in such a way that:

- ▶ *moving parts cannot start up while they are within the operator's reach*
- ▶ *persons cannot reach moving parts while the parts are moving, and*
- ▶ *the absence or failure of one of their components prevents starting or stops the moving parts. They must be adjustable only by means of intentional action.*

▶ 4.1 European Union standards, directives and laws relating to safeguards

A number of points in the above requirements are considered separately here:

Guards must, where possible, protect against the ejection or falling of materials or objects and against emissions generated by the machinery. The active direction of the protection is described here: it is not only necessary to consider hazards during the approach of people towards the danger zone; some hazards arise from the machinery itself, have an outward effect and therefore require protection.

Safeguards must cause minimum opportunities for obstruction to the view of the production process.

A further requirement for a fixed guard is that its fixing systems remain attached to the machinery or to the guard itself once the guard is removed. So in future, screws on protective covers for example will need to be fixed in such a way that they cannot be lost once the guard is removed.

This very strict requirement throws up a number of questions in respect of feasibility. For example, does this apply to all the screws on a safety fence? In an extreme case, even the floor fixings of the safety fence would be subject to this requirement.

The commentary entitled “Guide to application of the Machinery Directive 2006/42/EC – 2nd Edition – June 2010” issued by the European Commission provides an interpretation: the requirement is for fixed guards to be used where it is expected that the machine operator will remove them. A practical example would be opening up the guard for a monthly clean. In contrast, this does not need to apply to guards which are removed solely for general overhaul or for more major repairs. It is therefore advisable for machine manufacturers to classify their equipment accordingly.

Protective devices must be adjustable only by means of intentional action. This requirement makes particular sense in relation to light beam devices or light curtains. These devices are adjusted as the machine is put into service, after which point they should not be adjustable without good reason, otherwise the necessary safety distance may no longer be guaranteed.

▶ 4.1 European Union standards, directives and laws relating to safeguards

4.1.1 Standards for guards

In addition to the statutory regulations of the Machinery Directive, the following European standards currently exist relating to safeguards:

Standard	Title
EN ISO 14120:2015	Safety of machinery Guards – General requirements for the design and construction of fixed and movable guards
EN ISO 14119:2013	Safety of machinery – Interlocking devices associated with guards – Principles for design and selection

4.1.2 Standards for dimensioning of guards

Standard	Title
EN ISO 13857:2008	Machinery safety Safety distances to prevent hazard zones being reached by upper and lower limbs (ISO 13857:2008)
EN 349:1993+A1:2008	Machinery safety Minimum gaps to avoid crushing of parts of the human body

4.1.3 Standards for the design of protective devices or electroresponsive protective equipment

Standard	Title
EN 61496-1:2013	Safety of machinery Electrosensitive protective equipment – Part 1: General requirements and tests
EN 61496-2:2013	Safety of machinery Electrosensitive protective equipment – Part 2: Particular requirements for equipment using active optoelectronic protective devices (AOPDs)
CLC/TS 61496-3:2008	Safety of machinery Electrosensitive protective equipment – Part 3: Particular requirements for active optoelectronic protective devices responsive to diffuse reflection (AOPDDR)
EN ISO 13855:2010	Safety of machinery Positioning of safeguards with respect to the approach speeds of parts of the human body

▶ 4.2 Guards

A guard is part of a machine which is specifically required as a form of physical barrier to protect persons from the hazards of machinery. In some cases the same safeguards can simultaneously

protect the machine from persons, for example, if time-critical processes may not be interrupted by persons approaching at random. The study below considers the first scenario only.

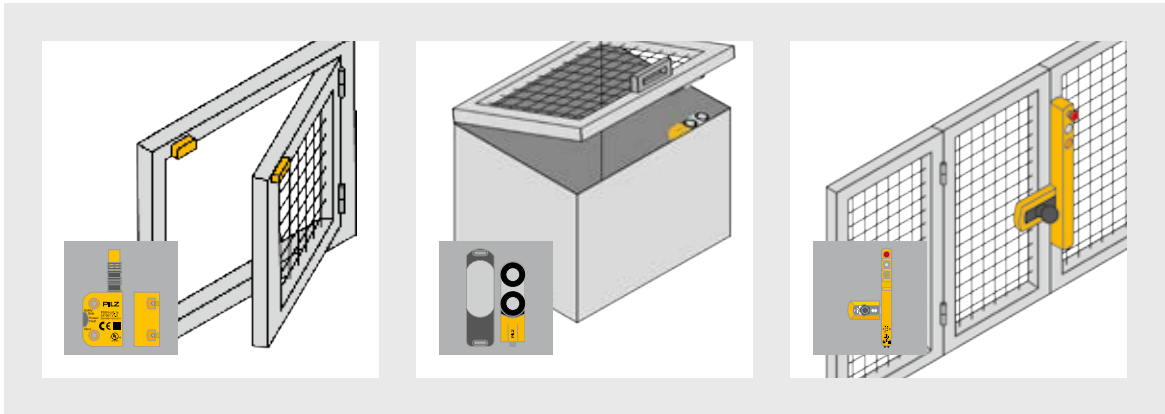

Examples of guards

A “guard” forms a physical barrier between the machine operator and the hazard, in contrast to “protective devices” or “electrosensitive protective equipment” such as light curtains and light beam devices, which are covered later. Safeguards of this type do not prevent access to a hazard, but detect a person or part of a person’s body when a hazard is approached. In this case, the hazard is shut down via a downstream controller so that the danger is removed before the hazard zone is reached. Depending on its design, a guard may be implemented as housing, casing, shield, door, cover or some other format. Guards are available in a wide range of types and formats, therefore.

4.2.1 Fixed guards

Fixed guards are permanently attached to the machine. This type of safeguard is suitable when it is unnecessary to remove the guard under normal operating conditions or when access is not required during the work process. Examples would be chain covers or grilles in front of motor fans.



► 4.2 Guards

4.2.2 Movable guards

If access is required to the danger zone, a movable guard can be used, e.g. a safety gate.

The frequency with which access is required will determine whether the guard needs to be fixed or movable. The standards can help you make this decision.

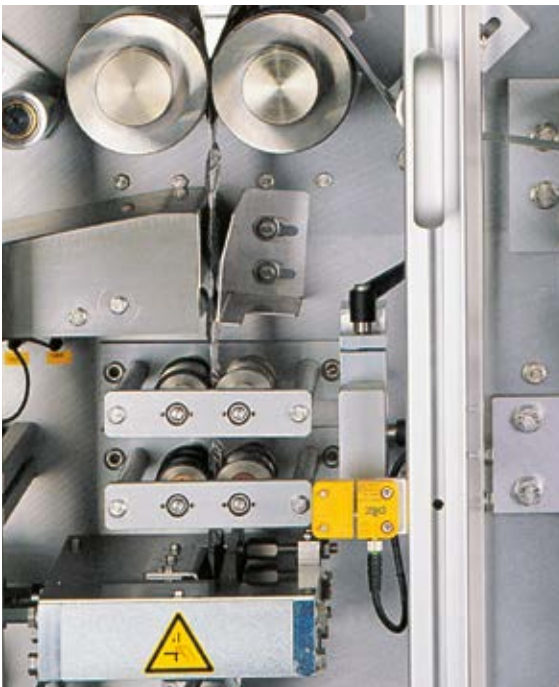

EN 14120

Where access is required only for machine setting, process correction or maintenance, the following types of guard should be used:

a) Movable guard if the foreseeable frequency of access is high (e.g. more than once a week), or if removal or replacement of a fixed guard would be difficult. Movable guards shall be associated with an interlock or an interlock with guard locking (see ISO 14119).

b) Fixed guards only if the frequency of access is low, their replacement is easy and the removal and replacement can also be performed within a safe work system.

Note: in this case, the term “interlock” means the electrical connection between the position of the safeguard and the drives to be shut down. In safety technology, the commonly understood mechanical “interlock”, meaning a lock, is called a “guard locking device”.

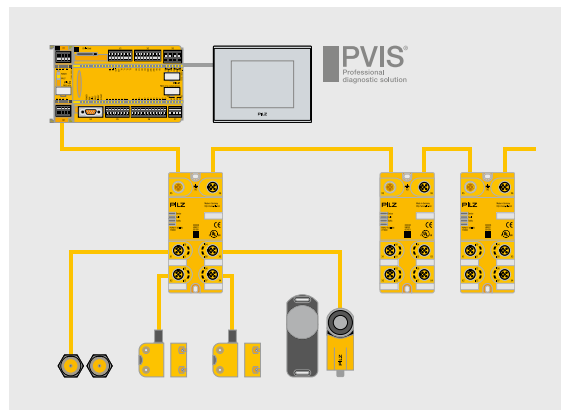

Monitoring several safety gates with one evaluation device thanks to individual diagnostics.

▶ 4.2 Guards

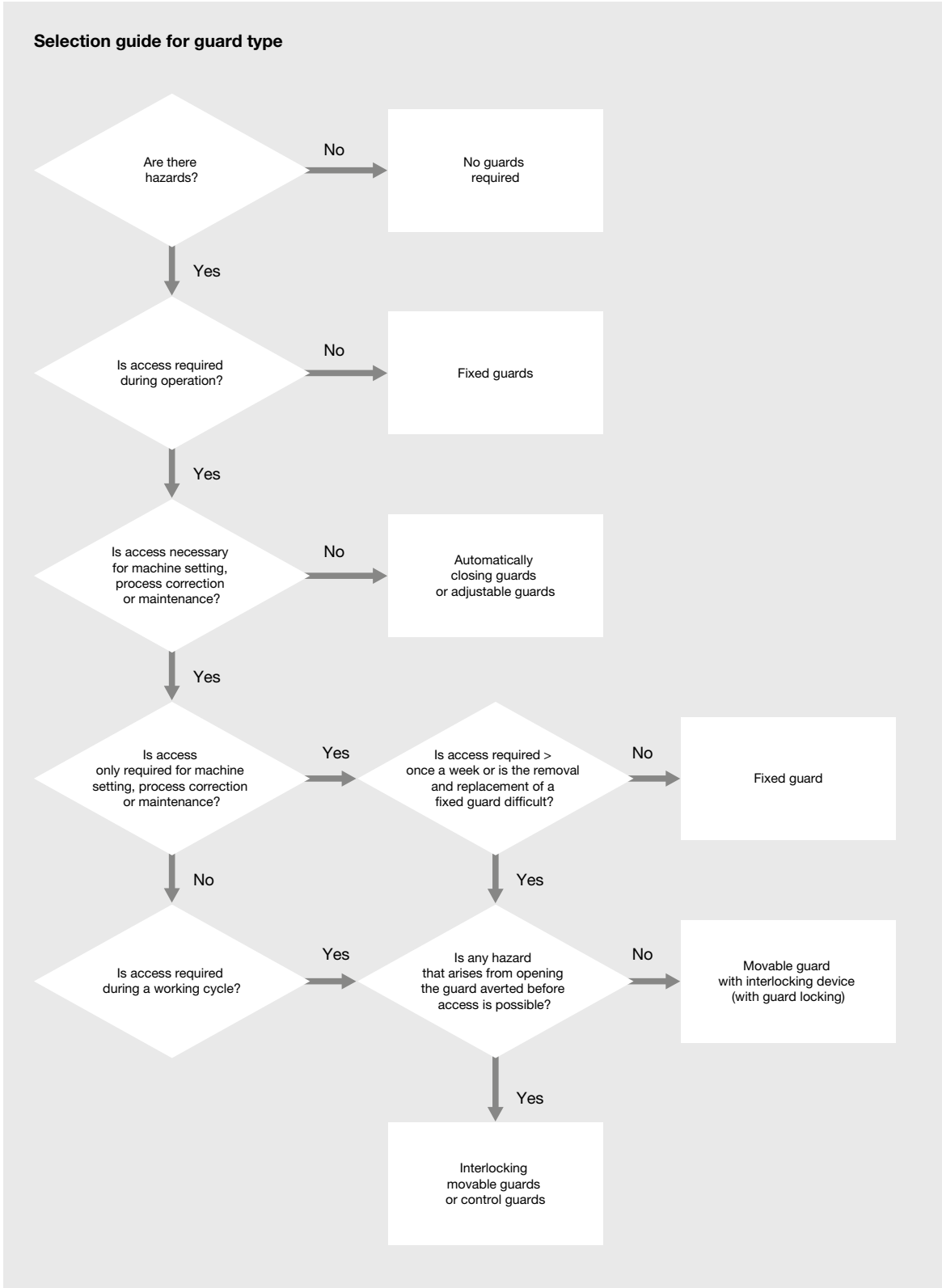

In accordance with EN 14120

► 4.2 Guards

Summary

Guards which need to be opened during production mode are generally designed as movable guards. These are in complete contrast to fixed guards, which are only operated rarely, for example, when they are opened to carry out maintenance or repair. This classification also needs to be well-founded because different costs will be associated with the type or selection of guard.

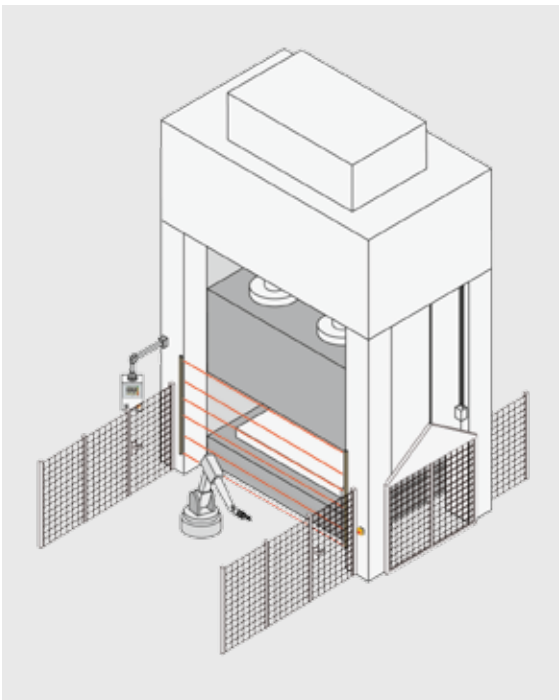

Fixed guards for maintenance or repair work

4.2.3 Further aspects on the design of safeguards

Once the decision has been made to use a movable guard, the next step is to determine the safety level of the corresponding interlock (safety integrity level SIL or performance level PL) in accordance with EN 62061 or EN ISO 13849-1. The corresponding control system is then designed and validated.

These control systems will include sensors in the form of switches, which detect the position of the guard. Via this detection feature, hazardous movements can be stopped as a result of the guard being opened. An additional safety function can prevent drives starting up unexpectedly when a safety gate is opened. The stopping time of hazardous movements will need to be considered: when a safety gate is opened, if it can be assumed that a drive with a long stopping time will generate a hazardous movement, this gate will require a guard locking device. The guard locking device must be unlocked by actively operating a release. This is the only way to guarantee that the safety gate is not released unintentionally as the result of a power failure, for example. In this case, it's also important to note that a person who is in the danger zone at the time of the power failure and has shut the safety gate behind him cannot be released by an unlock command on the machine control system. Such a case may be rare, but it is conceivable; for this reason guard locking device variants exist that have a mechanical release function. However, operating staff must be sure to have the appropriate actuation tool available or to be aware of how to operate the emergency release.

► 4.2 Guards

Connection in series for safety gate switches

When selecting sensors to scan movable guards, the question arises as to whether such sensors can be connected in series to an evaluation device,

and if so, how many? The answer to this question depends on the faults to be assumed or on the masking of these faults' detectability. The following example of safety gate sensors connected in series is intended to illustrate this point:

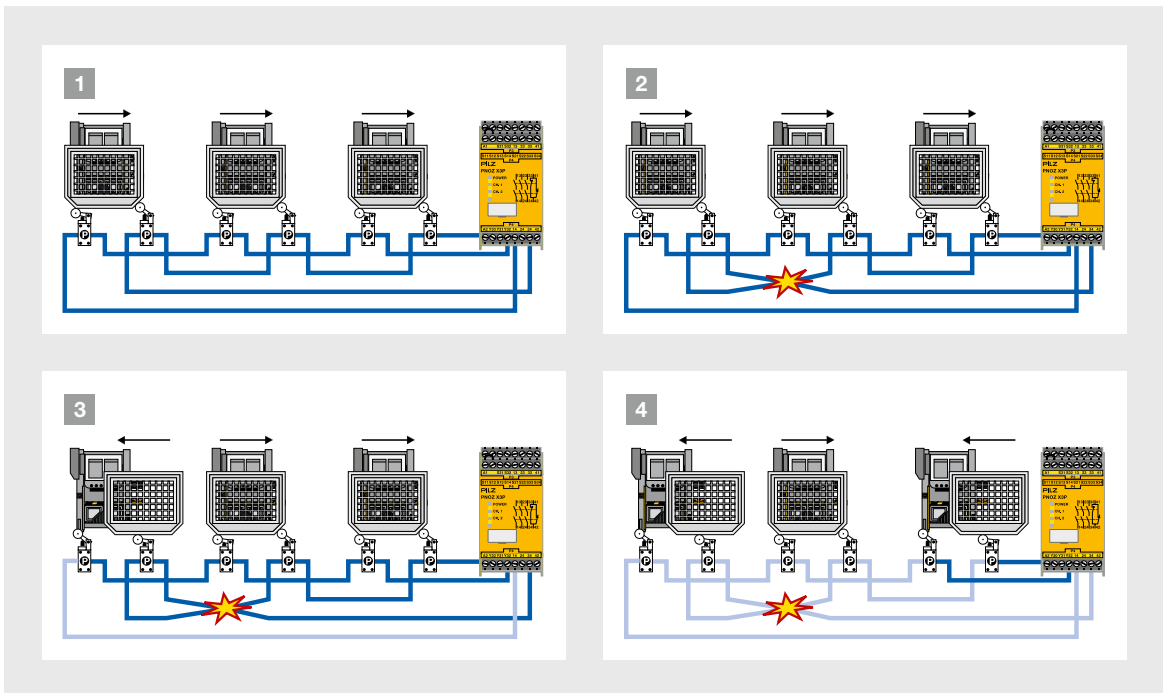

Example of safety gates connected in series

- 1 The example shows three safety gates connected in series to an evaluation device. Initially all the safety gates are closed and the relay's outputs are "on", i.e. the machine can be operated.
- 2 On the left-hand safety gate, a short circuit occurs in the line to the switch with the N/C contact: at first the fault is not detected and the machine can continue operating.
- 3 The left-hand safety gate is then opened, an event which the left switch signals to the relay. During a feasibility comparison of the two switches, the relay discovers an inconsistency and switches to a fault condition, i.e. once the safety gate is closed the machine cannot be restarted.
- 4 Now the right-hand safety gate is also opened. Via these signals the relay once again detects a normal condition. The fault condition is reset, the safety gates can once again be closed from left to right and the machine is ready to start up again.

This example illustrates an undetected fault in the safety circuit. An additional fault could cause the whole safety gate guard to fail to danger. These and similar faults are described by the term fault masking. In the current standards, the maximum diagnostic coverage (DC) that the switch can achieve is restricted, depending on the masking probability.

► 4.2 Guards

The occurrence of this type of fault masking should be taken into account on mechanical switches and magnetic proximity switches alike. Only switches with internal diagnostics and an OSSD output, as commonly found on RFID based switches, are unaffected by this.

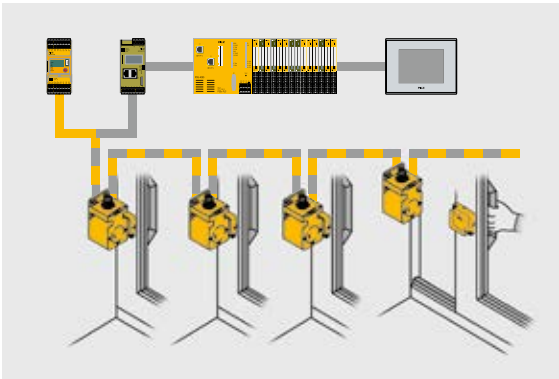

Safety switches with integrated fault detection

In practice, a single pair of switches assessed via a safety relay can achieve a DC = 99 %. Based on this premise, in ISO/TR 24119 the maximum DC for a group of interlinked switches is stated based on the number of switches connected in series and their frequency of operation.

As you can see in the table on the next page, masking restricts the achievable DC and, as a direct result, the achievable PL. If a group of interlinked switches is required to meet PL e, a technical solution is available using switches with integrated fault detection. As masking cannot occur in this case, it is possible to have interlinked switches without restricting the DC or PL.

Mechanical switches

In this context, the question also arises as to the need for mechanical redundancy and the number of independent switches on a safety gate. When installed correctly, magnetically operated and RFID proximity switches are often designed so that a single mechanical fault does not lead to the loss of the safety function; however, on mechanically operated switches (reed or roller switches), particular attention needs to be paid to the single-channel mechanical actuator. The documentation for the switch should always be checked carefully to establish whether the switch itself has any assured properties and if so, which. This is particularly important when a dual-channel electrical switching element is present.

Fault exclusions for the mechanical part of these switches are to be justified by the user if not explicitly confirmed by the switch manufacturer as part of the intended use. This is often very difficult if not impossible to achieve, as it is difficult to estimate the effects of wear, vibration, corrosion or inappropriate mechanical stress, for example. In cases such as these, to achieve PL d or PL e you must either use two mechanical gate switches per gate, one dual-channel magnetic switch or one RFID switch with OSSD output.

▶ 4.2 Guards

Number of frequently used movable guards ^{1) 2)}		Number of additional movable guards ³⁾	Maximum achievable diagnostic coverage (DC) ⁴⁾
0	+	2 to 4	Medium
		5 to 30	Low
		> 30	None
1	+	1	Medium
		2 to 4	Low
		≥ 5	None
> 1	+	≥ 0	None

¹⁾ If the frequency is greater than once an hour.

²⁾ If the number of operators that can open the separate safeguards is greater than 1, the number of frequently used movable guards is increased by 1.

³⁾ The number of additional movable guards can be decreased by 1 if one of the following conditions is met:

- If the minimum distance between the safeguards is greater than 5 m, or
- If none of the additional movable guards can be reached directly.

⁴⁾ If you can predict that fault masking will definitely occur (e.g. several movable guards are open at the same time as part of the normal operation or service), the diagnostic coverage is restricted to None.

Maximum achievable diagnostic coverage (DC) (simplified)

When additional parameters such as wiring type, test pulses and switch type are taken into account, more complex considerations can be provided beyond the values shown in the table. These can lead to better results in individual cases, but are always restricted to a maximum DC = medium.

There is also the question of how to proceed with a series connection of sensors with their own PL. In this case the diagnostics are an integral part of the sensor and are not influenced or reduced by a series connection. Nevertheless, the switch signal of the first sensor in the chain must be guided through all the other sensors before it can be processed by an evaluation device. A safety-related failure of another sensor in the chain could prevent it being forwarded. That's why in this case it's necessary to add up the failure probabilities of all the sensors in the chain – even if only the first sensor belongs to the safety function that is under examination.

▶ 4.2 Guards

Assessment of magnetic switches

One problem has proved to be critical when using magnetically operated gate switches (with reed contacts). If pairs of switches and safety relays are used and their mutual suitability has not been tested by the manufacturer, the machine builder must ensure that peak currents within the switch do not cause premature wear. This mainly affects pairs of reed switches with relay-based safety units.

For the assessment it is necessary to determine the maximum occurring peak current I_s (see Formula 1) and to compare this with the permitted peak current of the switch I_{Smax} . All switches in series connections must be considered, which is why the lowest of all the permitted peak currents must be greater than or equal to the maximum switching current (see Formula 2).

$R_{Smin}(i)$	Minimum internal resistance of switch i
$I_{Smax}(i)$	Maximum permitted peak current of switch i
U_{Pmax}	Maximum voltage
R_{Pmin}	Minimum internal resistance of safety relay
I_s	Maximum switching current

$$I_s = \frac{U_{max}}{R_{Pmin} + \sum_i R_{Smin}(i)}$$

Formula 1

$$I_s \leq \text{MIN}_i (I_{Smax}(i))$$

Formula 2

The problem of premature wear does not normally occur on mechanically operated switches and switches with OSSD output because wear on these switches is primarily determined via the average current and the thermal behaviour.

There is another new factor to consider from ISO 13855 relating to the consideration of switches on movable guards. This involves a potential hazard which might arise when a gate in a safety fence can be opened to such an extent that a person can access the danger zone through the opening without the corresponding gate switch receiving a signal change. This is more of a theoretical hazard but it can be averted by increasing the safety distance proportionate to the size of the undetected gate opening. In practice, the problem should never arise in the first place with the installation of a gate switch that has been selected and fitted to meet the requirements of the situation.

In this respect, the actual safety distance between the gate and site of the hazard is of greater practical relevance. Here, the question arises as to what happens when the safety gate in a safety fence is opened and a person enters the danger zone but the machine is still running down or braking. In this case, the relevant danger zones can still be reached if the person approaches at sufficient speed and the machine has a correspondingly long braking time. According to the standard, the calculation for the use of light curtains can be used in this case. Safety distance S is calculated as $S=(K \times T)$. K is the walking speed of the person of 1,600 mm/s and T is the time from the triggering of the gate switch to the machine stopping (i.e. safe status is achieved). The time that it takes to open the gate may be deducted. This can be identified either by considering how long this may take in theory or by timing it in practice, as no standard values are provided.

► 4.3 Protective devices

4.3.1 Active optoelectronic protective devices

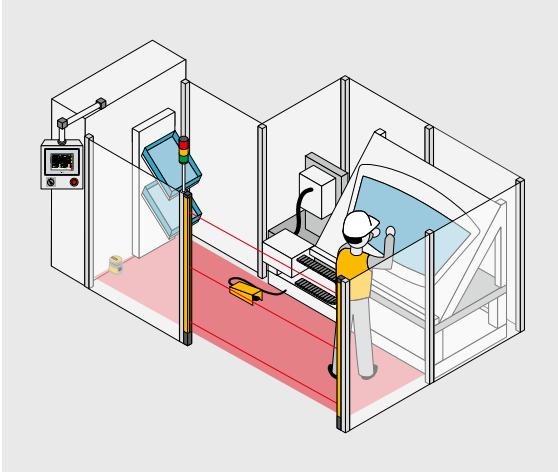

*Monitoring production areas
in which active intervention is required*

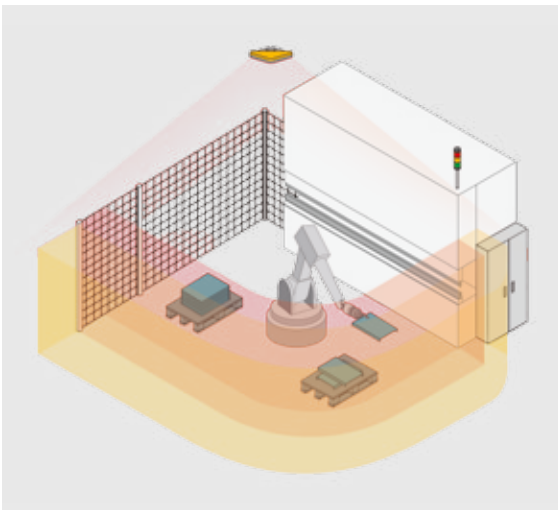

*Safe camera system for
three-dimensional zone monitoring*

Protective devices (electrosensitive protective equipment, abbreviated to ESPE below) are always used when access to the corresponding hazard zone is intended to be particularly easy to achieve and there are no hazardous repercussions to be anticipated from the machine itself (example: welding or grinding processes). To ensure that a potential hazard can be shut down quickly enough, the protective device must be installed at an appropriate distance. This distance or safety distance (S) is defined in EN ISO 13855 and depends in particular on the following factors:

- ▶ t_1 = Response time of the protective device itself.
- ▶ t_2 = Response time of the machine, i.e. the machine's stopping performance in response to the signal from the protective device
- ▶ C = Potential approach towards a danger zone undetected by the protective device, e.g. reaching through two beams of a light curtain undetected, depending on the distance of these beams
- ▶ K = Anticipated approach speed of the human body or parts of the human body. This factor is defined in EN ISO 13855 as 1,600 mm/s for walking speed and 2,000 mm/s for hand speed

The distance to be implemented is therefore

$$S = K \times (t_1 + t_2) + C$$

▶ 4.3 Protective devices

EN ISO 13855 defines the following preferential distances:

Resolution	Calculation formula (Distance S [mm])	Notes
$d \leq 40$ mm	$S = 2000 \times T + 8 (d-14)$	If the result is < 100 mm, a distance of at least 100 mm must be maintained.
	If the result is > 500 mm, you can use $S = 1600 \times T + 8 (d-14)$ as the calculation	In this case, S may not be < 500 mm.
$40 < d \leq 70$ mm	$S = 1600 \times T + 850$	Height of the lowest beam ≤ 300 mm
		Height of the highest beam ≥ 900 mm

Multiple single beams		No. of beams	Beam heights in mm
Multibeam	$S = 1600 \times T + 850$	4	300, 600, 900, 1200
		3	300, 700, 1100
		2	400, 900
Single beam	$S = 1600 \times T + 1200$	1	750
		If the risk assessment permits a single beam arrangement	

If the ESPEs form horizontal or inclined protected fields above an accessible area which requires safeguarding, the fields must be positioned at a minimum height, as pre-determined by the application and ESPE. Here too, the safety distance between the outer edge of the protected field and the danger point to be safeguarded should be such that the possibility of injuries resulting from the hazardous movement in the danger zone is excluded, bearing in mind the machine's stopping performance.

- ▶ Even when a guard has been carefully designed, any means of defeating it must be taken into account. Any possibility of reaching over or around a detection field needs to be excluded. As it is not always possible to cover any gaps alongside the detection field and an adjacent safety fence, safety distances between the person and the danger zones need to be observed here as well. The calculation of these distances is very similar to those for safety distances that apply to access to danger zones via a detection field. Particular attention needs to be paid to this important difference. In practice, it could for example be the case that access to a danger zone is protected by a vertically installed light grid. However, this light grid is often not as high as a person might be able to reach and - depending on a railing, for example - may be only 1,100 mm high. In this case, a person would be able to stand just in front of the light grid without interrupting the detection field. Furthermore, in this case the person can still lean forward and with an outstretched arm access the area behind the light grid with their hand. In order to avert hazards in this situation, minimum distances between the danger zone and light curtain are defined. These minimum distances are comprised of two components: walking speed and hand speed multiplied by the system's response time plus an additional value which depends on the height of the danger zone and the height of the safeguard. This additional value may be up to 1,200 mm. Where space is limited, it is worth looking at covering all possible means of permanently defeating the system.
- ▶ Information on positioning and sizing of pressure-sensitive mats can be found in chapter 7 of EN ISO 13855. Here as well, the familiar formula of $S = (K \times T) + C$ is used. In this case K equals 1,600 mm/s, derived from normal walking speed. A minimum distance of $C = 1,200$ mm is required to protect an outstretched arm or hand that will not be detected by the pressure-sensitive mat.
- ▶ The design of the safety distance S for the arrangement of two-hand control devices is based on the formula $S = (K \times T) + C$. In this case, C is 250 mm and K is 1,600 mm/s.

▶ 4.3 Protective devices

4.3.2 Further important aspects in connection with electrosensitive protective equipment

4.3.2.1 Restart

Once a safeguard has been triggered, a machine may not be restarted automatically after the protected field has been cleared. This should only be possible via a reset on a control device outside the danger zone, with visual contact.

4.3.2.2 Encroachment from behind

As well as the obvious protection for the danger zone it's also necessary to consider the possibility of reaching over, under or around the device, as well as encroaching from behind. A purely mechanical safeguard or another light curtain can be used to provide protection against encroachment from behind. If there is any possibility of defeating the safeguards, additional measures must be taken to protect them.

4.3.2.3 Muting

Muting is the temporary, automatic suspension of electrosensitive protective equipment so that material can be transported into and out of a danger zone, for example. Special sensors are used to ensure the muting controller only starts the muting cycle when the material is being transported through the protected field. The sensors must be positioned in such a way that persons cannot activate the muting sensors. If anyone should access the protected area, the potentially dangerous movement is shut down immediately.

The industry has developed special safety relays with muting function specifically for this case. Some light curtains also provide the option to mute the protected field only partially (blanking). In this process for example, the precise section through which the item is being transported is rendered passive. However, under no circumstances should anyone be able to reach the danger zone undetected via this deactivated section of the protected field. A design measure (e.g. a cover for the remaining free space) should be used to ensure that nobody can reach the danger zone from the side, in between the item and the protective device.

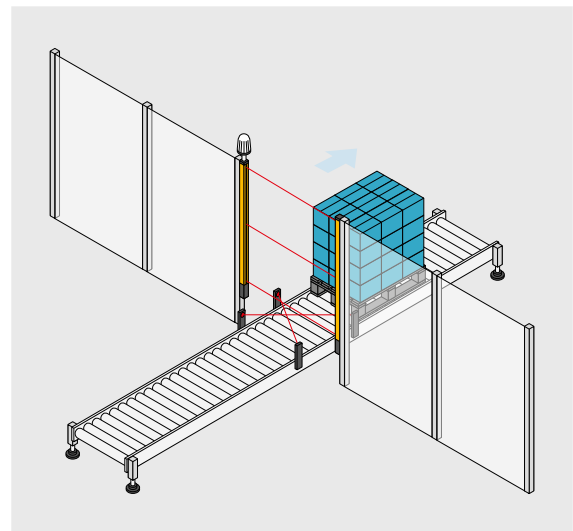

Muting with four muting sensors

► 4.3 Protective devices

4.3.3 Other sensor-based protective equipment

4.3.3.1 Laser scanners

A second ESPE installed horizontally or at an angle is often used to protect against encroachment of the ESPE from behind. Often this can only cover a small area. With larger zones to be safeguarded, a scanner can be used for additional optical monitoring of encroachment from behind. A laser beam scans the area to be monitored. If the beam is reflected by a foreign body, this will be detected and the hazardous movement will be safely shut down.

4.3.3.2 Safe camera systems

The latest developments on the market are safe camera systems for monitoring freely configurable zones. In contrast to simple sensors, they are able to record and analyse detailed information about the whole monitored zone. This way potentially hazardous work processes are safely monitored, protecting man and machine.

4.3.3.3 Pressure-sensitive mats

Many pressure-sensitive mats operate in accordance with the normally open principle: they require the use of special evaluation devices, which account for this actuation principle and guarantee appropriate fault detection. Pressure-sensitive mats that operate to the normally closed principle are also available, however; where a low safety level is required and the electrical loads are low, these can be used to activate contactors directly.

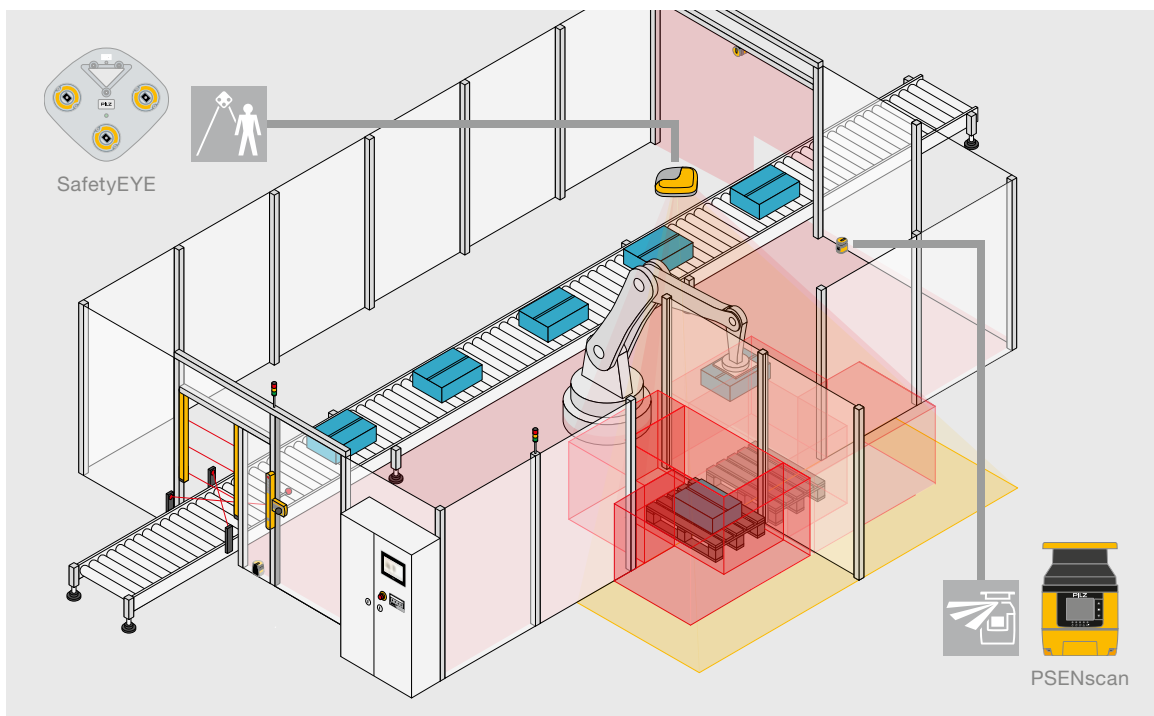

Safeguarding of danger zones with safety laser scanner and safe camera system

► 4.3 Protective devices

4.3.3.4 Two-hand control devices

Two-hand control devices are used on a workstation to keep both of the operator's hands committed locally; while the devices are operated, the hands are kept away from the danger zone. Various types of

two-hand circuits are defined and can be applied to suit the necessary level of protection: requirement levels for two-hand control devices:

Requirements	EN 574 Para.	Types				
		I	II	III		
				A	B	C
Use of both hands	5.1	◆	◆	◆	◆	◆
Release of either actuator initiates the cessation of the output signal	5.2	◆	◆	◆	◆	◆
Prevention of accidental operation	5.4	◆	◆	◆	◆	◆
Protective effect shall not be easily defeated	5.5	◆	◆	◆	◆	◆
Re-initiation of output signal only when both actuators are released	5.6	◆	◆	◆	◆	◆
Output signal only after synchronous actuation within max. 500 ms	5.7			◆	◆	◆
Use of category 1 in accordance with EN 954-1	6.2	◆		◆		
Use of category 3 in accordance with EN 954-1	6.3		◆		◆	
Use of category 4 in accordance with EN 954-1	6.4					◆

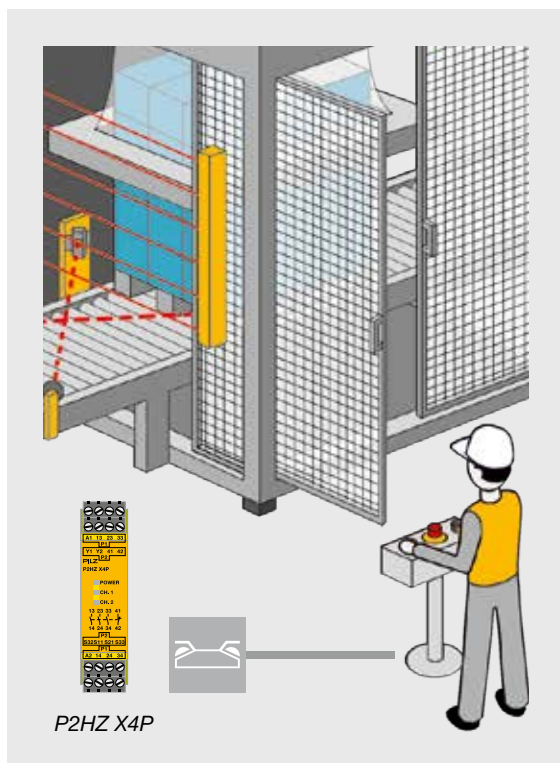

Evaluation of two-hand control circuits

The current edition of EN 574 still refers to the withdrawn standard EN 954-1. That's one of the reasons why EN 574 is currently under revision.

► 4.3 Protective devices

4.3.3.5 Functional safeguards

Avoidance of unexpected start-up in accordance with EN 1037 or soon DIN EN ISO 14118.

When an operation is in progress, the same question always arises: when a machine is brought to a halt via an operational stop command, how safely is the machine prevented from unintentionally restarting: what happens in this situation should a fault occur in the controller and a drive is started up unexpectedly? This is an issue which is just as important as the consideration of functional safety associated with “more obvious” safeguards. A key point to consider is the issue of converter-controlled drives. These drives are often stopped by signals such as “Zero Speed” or “Controller Inhibit”. The desire is often to avoid shutting down so as not to lose any data about the current drive status. In some cases, spontaneous shutdown of the connection between the mains and the converter or even between the converter and the drive is linked to device defects and so cannot be considered.

In cases such as these the machine designer has two options: if isolation from the energy supply is possible without device defects and without initiating other hazardous movements, standstill monitoring can be used. Although the converter-controlled drive is stationary it is still active, so it is monitored to check that it does not move. Should any movement occur on account of an error, the supply to the whole branch is shut down via a contactor. This solution assumes that the slight drive movement which occurs in the event of an error does not cause a hazard. The movement itself consists of two parts: the part which activates the sensor technology for monitoring and the part occurring before the protection circuit has reacted and a contactor has switched. These influences must be examined in a risk assessment.

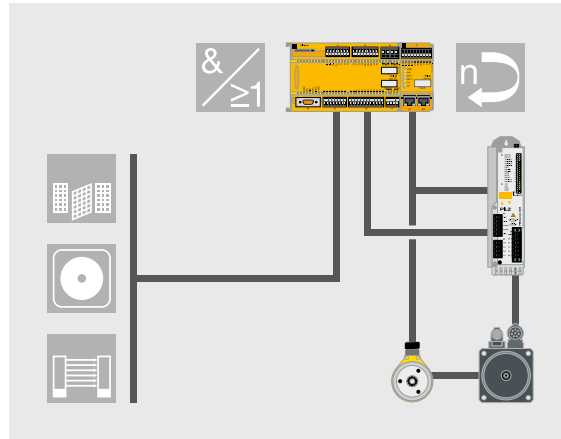

External drive monitoring through the PNOmulti safety system with speed monitoring

If an unintended movement such as this is unacceptable, safe drive technology must be used, which will prevent such faulty behaviour from the start (see also Chapter 7: Safe motion control).

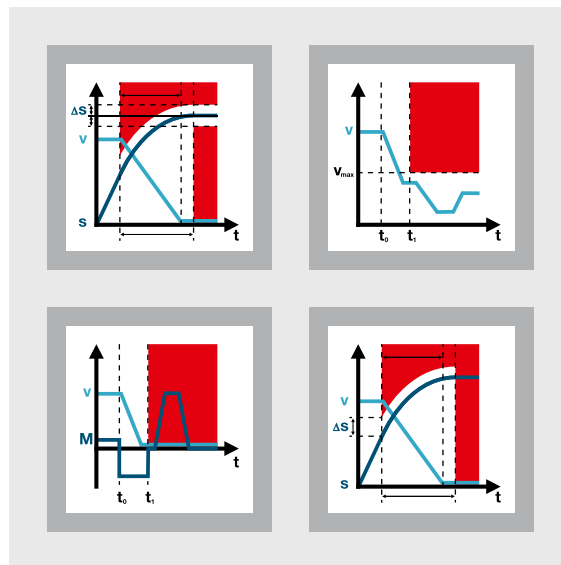

Examples of drive-integrated safety

▶ 4.4 Manipulation of safeguards

Dealing with safeguards and their manipulation is an issue in which the true causes have long been largely taboo. It's a situation that's difficult to understand, for without negative feedback, where can you start to make positive changes in the design of plant and machinery?

This situation has now changed: the confederation of commercial trade associations has published a study showing that safety equipment had been manipulated on almost 37% of the metal processing machinery examined. To put it plainly: in a good third of cases, manipulations have been detected and examined, although it's safe to assume that the unreported number may be somewhat higher.

One fact that hasn't changed, unfortunately, is the number of accidents recurring on machinery on which the safeguards are manipulated, as the BG bulletins regularly show.

4.4.1 Legal position

The legal position is clear: European and domestic law (e.g. EC Machinery Directive and Product Safety Act (ProdSG)) stipulate that it is the responsibility of machine manufacturers to only place products on the market that have an adequate level of safety. Manufacturers must establish all the potential hazards on all their machines in advance and assess the associated risks. They are responsible for developing a safety concept for the respective products, implementing that concept and providing the relevant documentation, based on the results of the risk analysis and risk assessment. Potential hazards must not be allowed to impact negatively on subsequent users, third parties or the environment. Any reasonably foreseeable misuse must also be included. Operating manuals should also clearly define the products' intended use and prohibit any known improper uses.

Design engineers should never underestimate the technical intelligence and creativity of machine users, as revealed by some dubious practices for defeating safeguards: it begins with crude but effective access to the mechanical structure of the signal flow chain and extends to skilfully filed keys for Type 2 safety switches. It includes loosened, positive-locking shaft/hub connections on switch cams, which are difficult to detect, as well as sophisticated short and cross circuits and disguised, carefully hidden but rapidly accessible override switches in N/C / N/O combinations, in the connection lead between the controller and the safety switch. This is only a small sample of the manipulations that are detected; it is by no means all.

► 4.4 Manipulation of safeguards



Design engineers should also consider that machine operators generally have a fair level of technical understanding and manual dexterity and also have considerably more time to become annoyed at ill-conceived operating and safety concepts and to consider effective “improvements” than the design engineers had for their development and implementation. Quite often they will have been reliant purely on the normative specifications, without being seriously aware of the realistic, practical requirements.

The task of taking into account potential manipulations in advance is therefore contradictory: design engineers are supposed to simulate the imagination and drive of the machine operators, who may frequently work under pressure but still have enough time and energy to work out alternative solutions. They are supposed to incorporate their expertise into their designs and, under today’s usual time constraints, convert this into safety measures which are manipulation-proof. A task that’s not always easy to resolve.

The checklist contained in EN ISO 14119 for assessment of the incentives for defeating interlocking devices performs a valuable service in predicting potential manipulations. It would also be desirable, however, if design engineers in future would increasingly put themselves in the user’s position and honestly and candidly ask themselves what they would do with the available operating and safety concept.

▶ 4.4 Manipulation of safeguards

4.4.2 Conduct contrary to safety – What does that mean?

Definition

Defeat in a simple manner

Render inoperative manually or with readily available objects (e.g. pencils, pieces of wire, bottle openers, cable ties, adhesive tape, metallised film, coins, nails, screwdrivers, penknives, door keys, pliers; but also with tools required for the intended use of the machine), without any great intellectual effort or manual dexterity (see also EN ISO 14119).

Manipulation

In terms of safety technology: an intentional, unauthorised, targeted and concealed intervention into a machine's safety concept for one's own benefit, using tools (see also EN ISO 14119).

Sabotage

Secret, intentional and malicious intervention into a technical system, in order to harm employees or colleagues. Word's origin: the wooden shoe (French: sabot) of an agricultural worker or Luddite in the 19th century, which was thrown into a lathe.

When designing and constructing machinery, manufacturers specify what the machines can and should be able to achieve. At the same time they also specify how the user should handle the machine. A successful design involves much more than simply the machine fulfilling its technological function in terms of the output quantity documented in the implementation manual, and the quality and tolerances of the manufactured products. It must also have a coherent safety and operating concept to enable users to implement the machine functions in the first place. The two areas are interlinked, so they ought to be developed and realised in a joint, synchronous operation.

Numerous product safety standards (e.g. EN 1010 or EN 12717) are now available, offering practical solutions. Nonetheless, planning and design deficiencies are still to be found, even on new machinery. For example:

- ▶ Recurring disruptions to the workflow, brought about for example by deficiencies in the technological design or in the precision of the components (direct quote from a plant engineer: "The greatest contribution design engineers can make to active health and safety is to design the machines to work exactly in the way which was promised at the sale.")
- ▶ Opportunities for intervention or access, e.g. to remove the necessary random samples, are either difficult or non-existent
- ▶ Lack of segmented shutdowns with material buffers, so that subsections can be accessed safely in the event of a fault, without having to shut down the entire plant and lose valuable time starting it up again

Ill-conceived safety concepts are still found in practice on a regular basis. Many errors are made with interlocked safeguards, for example, when

- ▶ Non-hazardous or frequently operated function elements, e.g. actuators, storage containers, filler holes, are installed behind (interlocked) safeguards
- ▶ The interlock interrupts the hazardous situation quickly and positively when a safeguard is opened, but afterwards the machine or process is unable to continue or must be restarted

► 4.4 Manipulation of safeguards

Nobody has any doubt that designers act to the best of their knowledge and belief when they design and implement technological functions as well as those functions relating to persons or operators. One can't really blame them for assuming that subsequent users will behave reasonably and correctly when using the machinery. But it's precisely here that caution is advised: human behaviour is mainly benefit-oriented, both in everyday and in working life. People strive to perform the tasks they are given or have set themselves as quickly and as well as necessary, with the least exertion possible.

People will also try to intervene actively in support of a process if it isn't running quite as it should. They will make every effort to rectify troublesome faults as quickly and simply as possible. If they can't because of the design (and the fault rectification procedure set down in the operating manual), they will find a way out by defeating the interlock, for example. They will often regard the additional work as a personal misfortune for the smooth performance of their work function. By defeating the safety measures that have been provided, the fault rectification procedure is much less complex and is therefore seen as a success. Successful behaviour tends to be repeated until it is reinforced as a habit, which in this case is unfortunately contrary to safety and indeed dangerous.

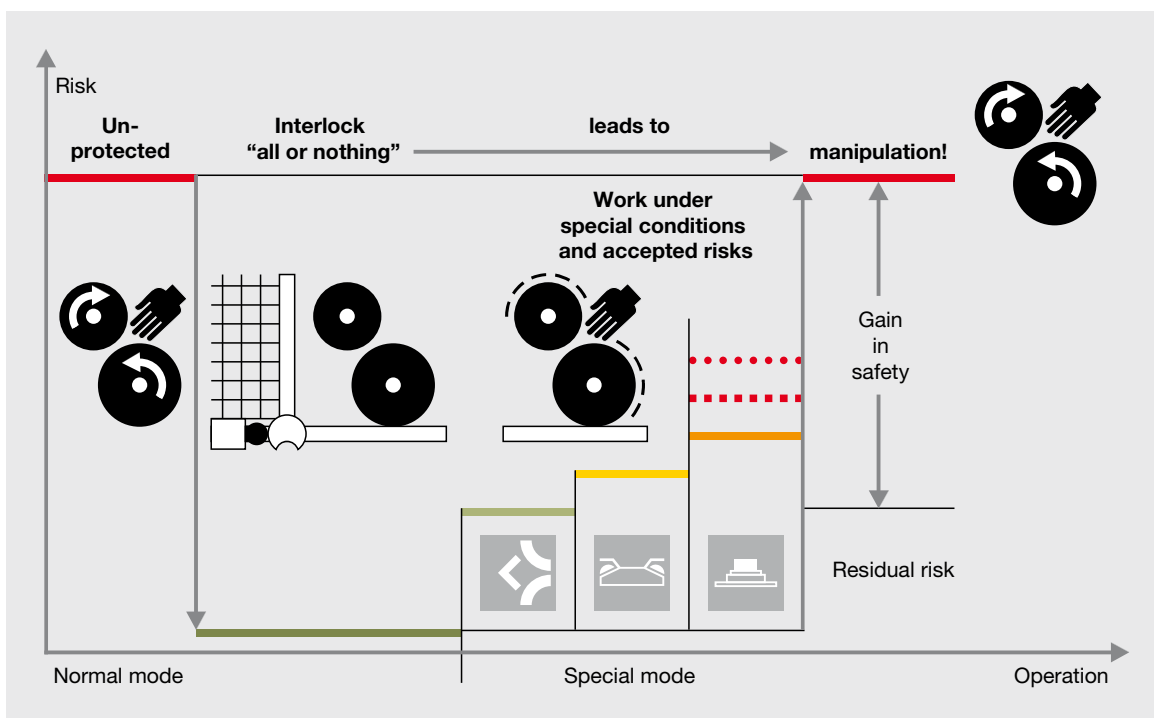

Interlocking concept for special operating modes

▶ 4.4 Manipulation of safeguards

The more such rule breaches are tolerated at management level and go unsanctioned, the greater the probability that the rules will continue to be breached without punishment. Incorrect conduct becomes the new, informal rule. For over the course of time, the awareness of the risks that are being taken will lessen and those involved become convinced that they have mastered the potential hazards through vigilance. But the risk is still there; it's just waiting for its chance to strike.

There's no question that the factors that trigger an accident seem initially to rest with the conduct of those affected. However, design errors on the machine encourage the misconduct that's so dangerous (even life threatening) to those involved. Such machines do not comply with the EC Machinery Directive. In other words: it is the manufacturer's responsibility to design protective measures in such a way that they provide a sufficient level of safety, in accordance with the determined risk, while still guaranteeing the functionality and user friendliness of the machine. Ultimately it is always better to accept a calculable, acceptable residual risk with a carefully thought out safety concept, tailored to the practical requirements, than to expose the machine operator to the full risk of insecure processes following successful manipulation.

4.4.3 What can designers do?

Designing safety-related machinery means more than simply complying with regulations and other legal stipulations. Consulting the relevant regulations and standards, dismissively asking "Where does it say that?!" – to ensure that only those safety measures that are strictly necessary are implemented – is no substitute for deep consideration of solutions that are not only right for safety and right for people but are also fit for purpose.

Most of all, design engineers must be more sensitive to operators' demands for operability of machines and safety devices, which stem from practical experience, and provide a serious response to these. This does not make the safety-related design more difficult, but is the basis on which to build user-friendly, safety-related machinery. It's essential that the actual development and design is preceded by a detailed, candid analysis of the operational requirements, the results of which are recorded in a binding requirement specification. If not, the situation may arise in which the machine and its incorporated safety measures may not be accepted. What's more, they could provoke users into coming up with "new ideas", most of which do not support health and safety. These in turn could conjure up a whole new set of hazards, which were far from the minds of the original designers.

Nonetheless: manipulation rarely occurs voluntarily; it usually indicates that machine and operating concepts are not at their optimum. Conduct contrary to safety should always be anticipated when:

- ▶ Work practices demand actions which do not have a direct, positive impact on outcomes
- ▶ Work practices enforce constant repetition of the same work steps, or fresh approaches are always required in order to achieve work targets
- ▶ Safeguards restrict the line of vision and room for manoeuvre required to perform the activity
- ▶ Safeguards impede or even block the visual/auditory feedback required to work successfully
- ▶ Troubleshooting and fault removal are impossible when the safeguards are open

► 4.4 Manipulation of safeguards

In other words: manipulations must always be anticipated when restricted machine functions or unacceptable difficulties tempt, or even force, the machine user to “improve” safety concepts. Manufacturers must design protective measures so that the functionality and user friendliness of the machine are guaranteed at a tolerable, acceptable level of residual risk: predict future manipulation attempts, use design measures to counteract them and at the same time improve machine handling.

The obligations of machine manufacturers are threefold:

1. Anticipate reasons and incentives for manipulation, remove the temptation to defeat interlocks by creating well thought-out operating and safety concepts for machinery.
2. Make manipulation difficult by design, e.g. by installing safety switches in inaccessible areas, using hinge switches, attaching safety switches and their actuators with non-removable screws, etc.
3. Under the terms of the monitoring obligation specified in the Product Safety Act (ProdSG), systematically identify and rectify any deficiencies through rigorous product monitoring with all operators (reports from customer service engineers and spare part deliveries are sometimes very revealing in this respect!).

The client who places the order for a machine can also help to counteract manipulation by talking to the machine manufacturer and candidly listing the requirements in an implementation manual, binding to both parties, and by talking openly about the faults and deficiencies within the process, then documenting this information.

4.4.4 User-friendly guards

It's important to recognise that safeguards – even interlocked guards – are always willingly accepted and are not manipulated when they do not obstruct but actually support or even simplify the workflow. Faults in the safety concept which force operators to manipulate safeguards are genuine design faults, for which the machine manufacturer is liable in some circumstances. Safety-related solutions with an acceptable residual risk must be put in place, not just for fault-free normal operation, but also for setup, testing, fault removal and troubleshooting.

Simply to make manipulation attempts more difficult on a technical level only appears to solve the problem (see also EN ISO 14119). For if there is enough pressure, a “solution” will be found. It's more important to eliminate the reason for manipulation. What's needed is not excessive functionality (even in terms of safety technology), but user friendliness. If there's any doubt as to whether the safety concept is adequate, it's recommended that you seek expert advice from the relevant employer's liability insurance association or from the safety component manufacturer.

► 4.4 Manipulation of safeguards

Guards use physical barriers to stop people and hazardous situations coinciding in time and space. Their essential design requirements are stated in EN 14120 and ISO EN 14119. Safety-related and ergonomic aspects must be taken into account alongside questions regarding the choice of materials and consideration of mechanical aspects such as stability. These factors are decisive, not just in terms of the quality of the guard function but also in determining whether the safeguards, designed and constructed at considerable expense, will be used willingly by employees or be defeated and even manipulated.

Experience shows that despite all the protestations, almost every safeguard has to be removed or opened at some point over the course of time. When safeguards are opened, it's fundamentally important that hazards are avoided where possible and that employees are protected from danger. The reason for opening, the frequency of opening and the actual risk involved in carrying out activities behind open safeguards (see the following illustrations) will determine the procedures used to attach and monitor safeguards.

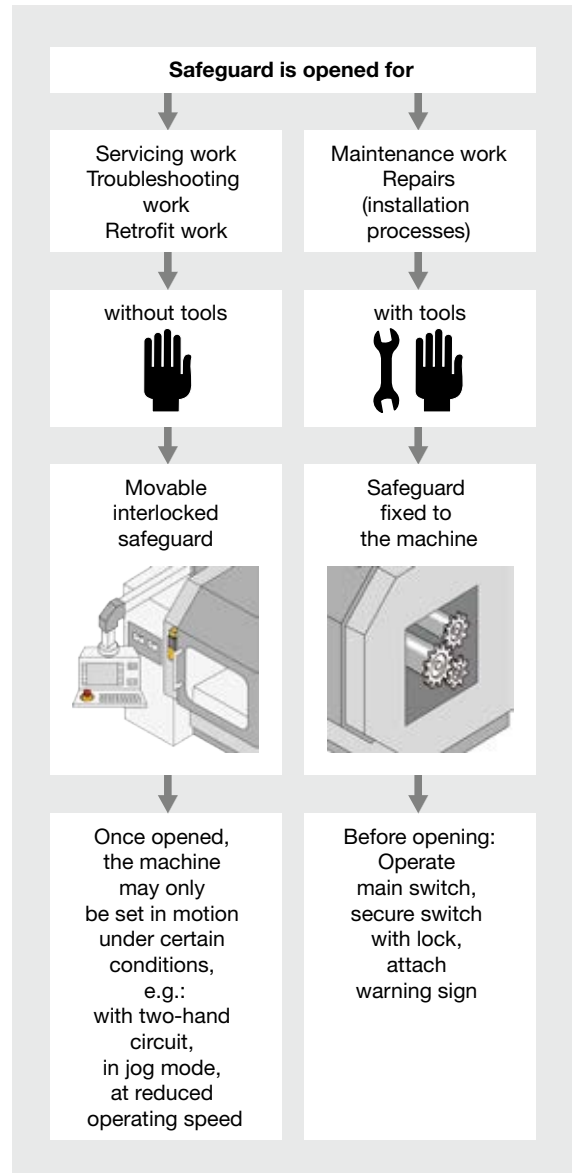

Opening procedures on safeguards.

► 4.4 Manipulation of safeguards

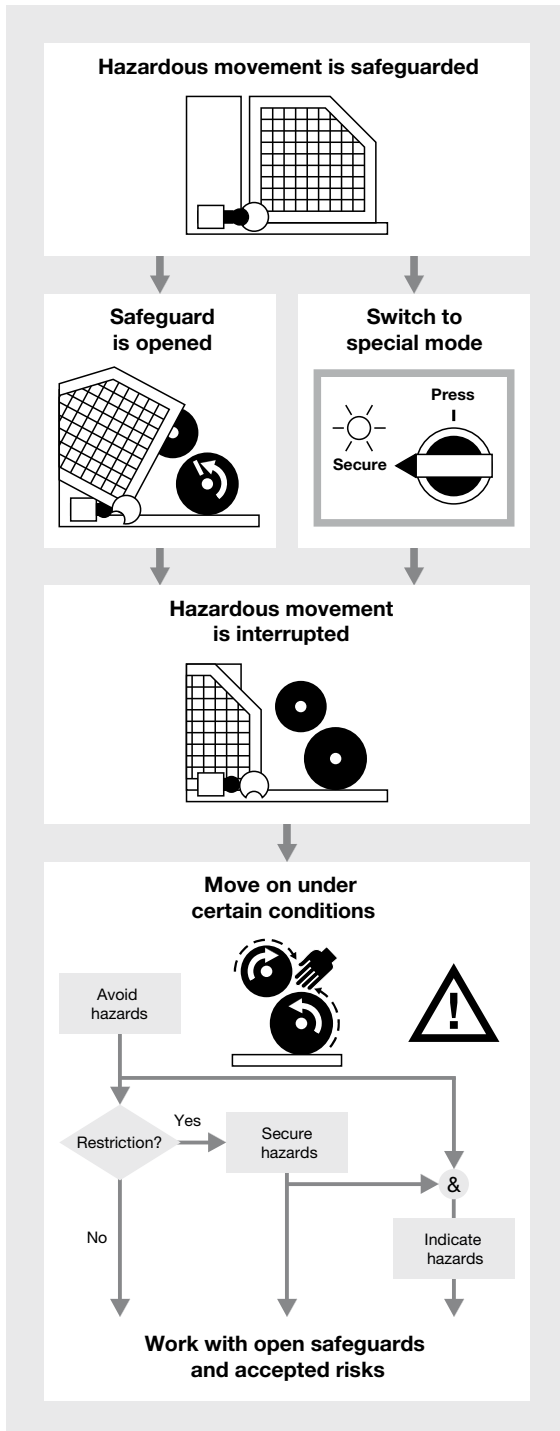

Interlocking concept for safeguards.

If safeguards must be opened frequently as a condition of operation, this must be possible without tools. Where there are hazardous situations, use of an interlock or guard locking device must be guaranteed. Further protective measures must be adjusted to suit the resulting risk and the drive/technological conditions, to ensure that the activities which need to be carried out while the safeguards are open can be performed at an acceptable level of risk.

4.4.5 Conclusion

Just some final words in conclusion for all designers: designing interlocks so that absolutely no movement of the machine or subsections is possible once the safeguard has been opened actually encourages the type of conduct which is contrary to safety and, ultimately, leads to accidents. Nevertheless, it is the causes you have to combat, not the people. If a machine does not operate as intended, users will feel they have no choice but to intervene. In all probability, the machine will “reciprocate” some time with an accident. Which is not actually what it was designed to do!



5

Safe
control
technology



► 5 Safe control technology

5	Safe control technology	
5.1	Safety relays _____	5-4
5.1.1	Overview of safety relays _____	5-4
5.1.2	Structure and function of safety relays _____	5-4
5.1.3	Relays and electronics _____	5-6
5.1.4	Greater flexibility during installation _____	5-7
5.1.5	Special features and functions _____	5-10
5.2	Configurable safe small controllers _____	5-11
5.2.1	Safety-related and non-safety-related communication _____	5-13
5.2.2	Customer benefits from function and logic elements _____	5-16
5.3	Safety and automation _____	5-21
5.3.1	Overview of safety controllers _____	5-21
5.3.2	Integration within the automation environment _____	5-22
5.3.3	Safe decentralisation and enable principle _____	5-24
5.3.4	Function blocks in safe controllers _____	5-25
5.3.5	Mission time of safety functions _____	5-26
5.3.6	Use of used components _____	5-26
5.4	Using safety controllers to achieve safe control technology _____	5-27
5.4.1	Overview _____	5-27
5.4.2	Structures of the safe control technology _____	5-28
5.4.3	Modularisation of the automation function _____	5-29
5.5	Safe control technology in transition _____	5-30
5.5.1	New requirements for safe control technology _____	5-30
5.5.2	Complex yet simple – no contradiction _____	5-32
5.5.3	From static to dynamic safety _____	5-37
5.5.4	About Industrie 4.0 _____	5-38

► 5 Safe control technology

In the early days of control technology, the focus in the controller was on the function and therefore the process image. Relays and contactors activated plant and machinery. Where there were shutdown devices or devices to protect personnel, the actuator was simply separated from the supply when necessary. However, people gradually realised that this type of protection system could be rendered inoperational in the event of a fault: the protective function would no longer be guaranteed. As a result, people began to consider the options for safeguarding this type of separation function. Special relay circuits, such as the 3 contactor combination, were one of the initial outcomes of these considerations. These device combinations ultimately led to the development of the first safety relay, the PNOZ.

Safety relays, therefore, are devices which generally implement safety functions. In the event of a hazard, the task of such a safety function is to use appropriate measures to reduce the existing risk to an acceptable level in the event of a hazard. These may be safety functions such as emergency stop, safety gate function or even standstill monitoring on a drive. Safety relays monitor a specific function; by connecting them to other safety relays they guarantee total monitoring of plant or machinery.

The first safety-related controller ultimately came from the desire to connect functions flexibly through programming, similar to the way this is done on a programmable logic controller (PLC).

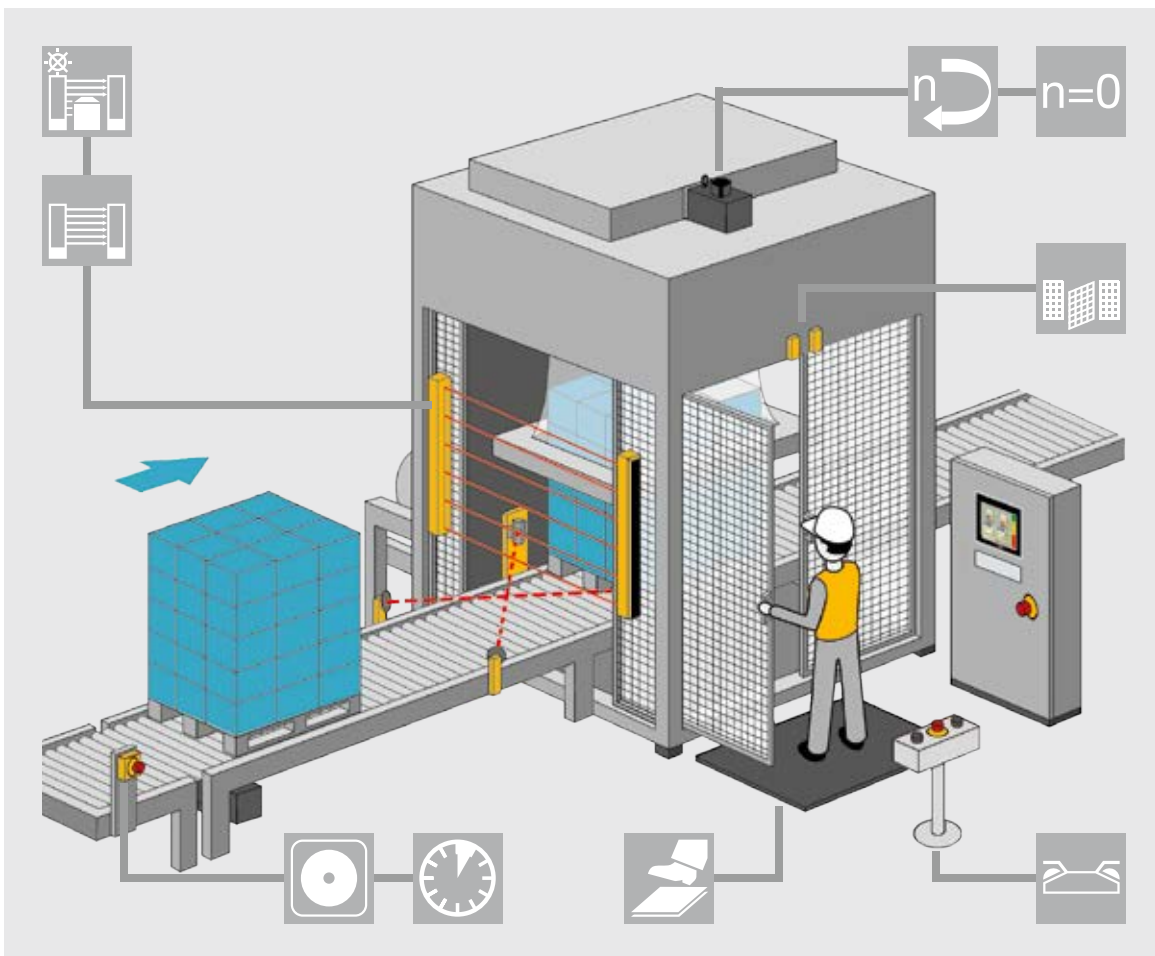

Safety functions for all requirements

► 5.1 Safety relays

Configurable safe small controllers like PNOZmulti are a combination of safety relay and safety controller. Having considered the advantages and disadvantages of both systems, they combine the simplicity of a relay with the flexibility of a safety controller. Although the primary focus for safety relays and safety controllers is to monitor safety functions, the current trend is towards intelligent dovetailing of safety and automation functions within one system.

5.1.1 Overview of safety relays

Safety relays perform defined safety functions. For example, they

- ▶ Stop a movement in a controlled and therefore safe manner
- ▶ Monitor the position of movable guards
- ▶ Interrupt a closing movement during access.

Safety relays are used to reduce risk: when a fault occurs or a detection zone is violated, they initiate a safe, reliable response. Safety relays are encountered in almost every area of mechanical engineering, mainly where the number of safety functions is quite manageable. However, increasing efforts are being made to integrate diagnostic information into control concepts as well as overall concepts. That's why in future safety relays and even safe small controllers with communications interfaces will be more prevalent in plant and machinery.

Safety relays have a clear structure and are simple to operate, which is why no special training measures are required. To use these devices successfully, all that's generally needed is normal technical knowledge of electrical engineering and some awareness of the current standards for machine safety. The devices have become so widely used because of their compact design, high reliability and, importantly, the fact that the safety relays meet all the required standards. They have now become an integral component of any plant or machine on which safety functions have a role to play.

Since the first safety relays were developed – initially with the sole intention to monitor the emergency stop function – a wide range of devices have now become established, performing some very specific tasks in addition to the monitoring functions: for example, monitoring speeds or checking that voltage is disconnected on a power contactor. The devices are designed to work well with the sensors and actuators currently available on the market. Today, a safety relay is available for practically every requirement. With their diverse functionality, safety relays can implement almost any safety function, for example, monitoring the whole safety chain from the sensor to the evaluation logic, through to activation of the actuator.

5.1.2 Structure and function of safety relays

Today's safety relays are distinguished primarily by their technological design:

- ▶ Classic contact-based relay technology
- ▶ With electronic evaluation and contact-based volt-free outputs
- ▶ To fully electronic devices with semiconductor outputs

Nothing has changed in the fundamental requirement that safety relays must always be designed in such a way that – when wired correctly – neither a fault on the device nor an external fault caused by a sensor or actuator may lead to the loss of the safety function. Technological change has advanced the development of electronic safety relays, which offer much greater customer benefits: electronic devices are non-wearing, have diagnostic capabilities and are easy to incorporate into common bus systems for control and diagnostic purposes.

► 5.1 Safety relays

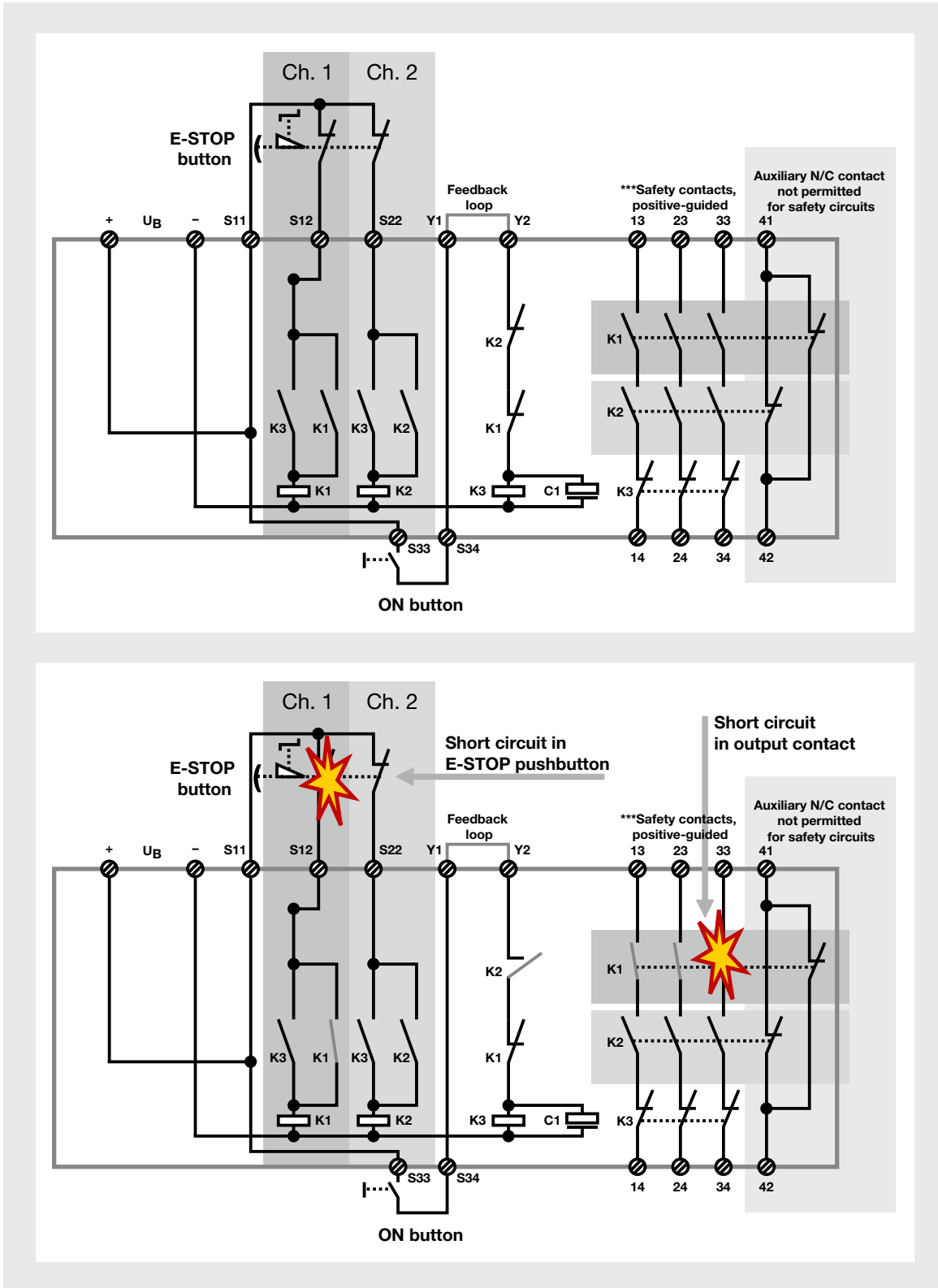

Structure and function of a safety relay

► 5.1 Safety relays

The typical design of a first generation safety relay in relay technology is based on the classic 3 contactor combination. The redundant design ensures that wiring errors do not lead to the loss of the safety function. Two relays (K1, K2) with positive-guided contacts provide the safe switch contacts. The two input circuits CH1 and CH2 each activate one of the two internal relays. The circuit is started via the start relay K3. There is another monitoring circuit between the connection points Y1 and Y2 (feedback loop). This connection is used to check and monitor the position of actuators, which can be activated or shut down via the safety contacts. The device is designed in such a way that any faults in the input circuit are detected, e.g. contact welding on an emergency stop pushbutton or on one of the safety contacts on the output relay. The safety device stops the device switching back on and thereby stops the activation of relays K1 and K2.

5.1.3 Relays and electronics

The latest generation of safety relays operates using microprocessor technology. This technology is used in the PNOZsigma product group, for example, and offers further additional benefits over conventional relays. There is less wear and tear thanks to the use of electronic evaluation procedures and the diagnostic capability, plus the safety relays also reduce the number of unit types: one device can now be used for a variety of safety functions and sensors, e.g. for contact-based sensors such as emergency stop pushbuttons or mechanical safety gate switches, but also for sensors with semiconductor outputs such as non-contact safety gate switches, light curtains and two-hand control devices. As electronic safety relays have a more compact design, they take up much less space. The reduced size enables more

functions to be implemented in the same effective area. Adjustable start-up test and optional reset for restarting allow for flexible application of the devices. As a single device type can implement several different safety functions at once, savings can be made in terms of stockholding, configuration, design and also when commissioning plant and machinery. Not only does this reduce the engineering effort in every lifecycle phase, it also simplifies any additions or adjustments that are required.



Electronic safety relays and small controllers can be expanded in the simplest way possible. Whether you use additional contact blocks or function modules: adapting to the specific requirements of the respective plant or machine is a simple, straightforward process, with contacts expanded via connectors. With just a single base unit, plus additional expansion units if required, users can fully implement all the classic functions.

► 5.1 Safety relays

5.1.4 Greater flexibility during installation

For many years, wiring of the individual functions on safety relays was a complex, problematic procedure which had a negative impact on the installation process. Imagine the following situation on a machine: a safety gate is intended to prevent random, thoughtless access to a danger zone. Access is only possible once the hazardous movement has been stopped and the machine is in a safe condition, at least within the danger zone. However, the intention is for various drives to be operable at reduced speed, even when the gate is open, for installation and maintenance purposes for example. An enable switch has therefore been installed, which must be operated simultaneously.

If these requirements are to be implemented in practice, so that the operator is protected from potential hazards, a substantial amount of wiring will be needed to connect the individual safety devices. As well as the actual protection for the safety gate, safety relays will also be required for the enable switch, to monitor "Setup" mode, and for the master emergency stop function. Reduced purely to the logic relationships, the connections could look as follows:

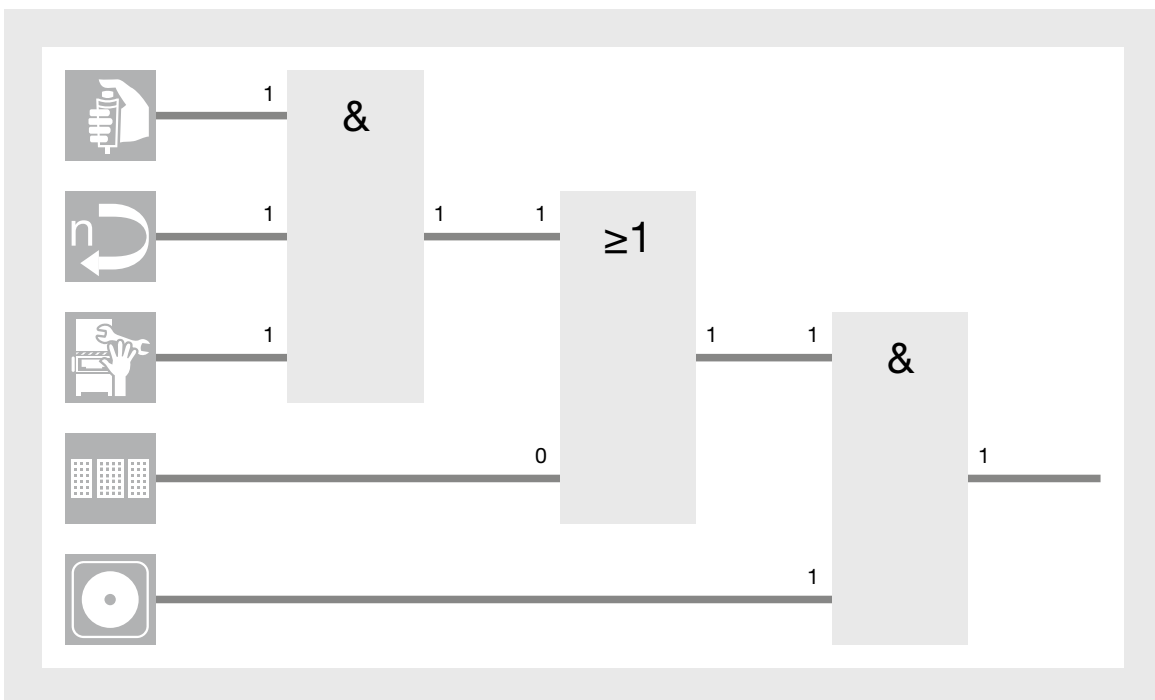

Wiring example

► 5.1 Safety relays

5.1.5 Special features and functions

A key benefit of safety relays is their ability to specialise. They have a clear, self-contained task to fulfil, so specific customer requirements have led to a wide range of safety relays with particular functions and features: these include devices with muting function, with safe monitoring of speed, standstill and monitored disconnection, as well as safety relays with special properties for the Ex area. The examples below illustrate some of these functions.

5.1.5.1 Muting function

The muting function is used to automatically and temporarily suspend a safety function implemented via a light curtain or laser scanner for a particular purpose. A muting function is frequently used to transport material into or out of a danger zone.

5.1.5.2 Safety relays for the Ex area

Some of the most hazardous plant and machines are those that manufacture, transport, store or process dust, flammable gases or liquids. Explosive compounds may be produced during these processes, which could present a danger beyond the immediate environment. Potentially explosive atmospheres like these require special devices, on which electrical sparking on contacts and impermissibly high temperatures must be prevented. Such safety relays must provide an intrinsically safe output circuit and volt-free contacts for potentially explosive areas. Depending on the area of application, different versions of safety relays are available that are approved for use in potentially explosive areas.



Certified safety relay for the Ex area

► 5.2 Configurable safe small controllers

Similar to progress in the automation technology sector, safe control technology has gradually developed from hard-wired contactor technology to contact-based safety relays and devices with integrated logic function and beyond to flexible, configurable small controllers. The idea was to make safe control technology more transparent and manageable for the user. This was the major driving force behind development of the devices and ultimately led also to the development of new types of configuration tools, which graphically display function and logic and then forward the configured setting to the base unit via chip card or USB stick. The result is a high degree of flexibility for the responsible electrical design engineer; their plans only have to consider the number of digital and analogue inputs/outputs required. They can incorporate the functions at some later date and adapt them to suit the changed situation if necessary. At the same time, any work involved in wiring the logic functions also disappears.

With this generation of devices, the safety functions and their logic connections are configured exclusively via the software tool. The manufacturer provides the safety functions as function elements; specified bodies such as BG or TÜV will have already tested them for safety. With the help of safe function elements and the logic connection between the elements, plant or machine builders create the safety-related application they require, an application which they would previously have implemented by wiring contactors and relays in a laborious, time-consuming process. Contacts and wires are replaced by lines between the ready-made elements. An electrical circuit diagram showing the logic functions is no longer required.



Logic connections between the elements for simple configuration

► 5.2 Configurable safe small controllers

Not only is it easy to connect the function elements to each other, a simple click of the mouse is all it takes to adapt them fully to the requirements of the relevant application. Adjustable properties define the behaviour of the individual elements within the application: whether single or multi-channel,

with or without automatic restart, e.g. when a safety gate is closed. Parameters that determine how an element will behave can be easily set in accordance with the application's safety requirement.

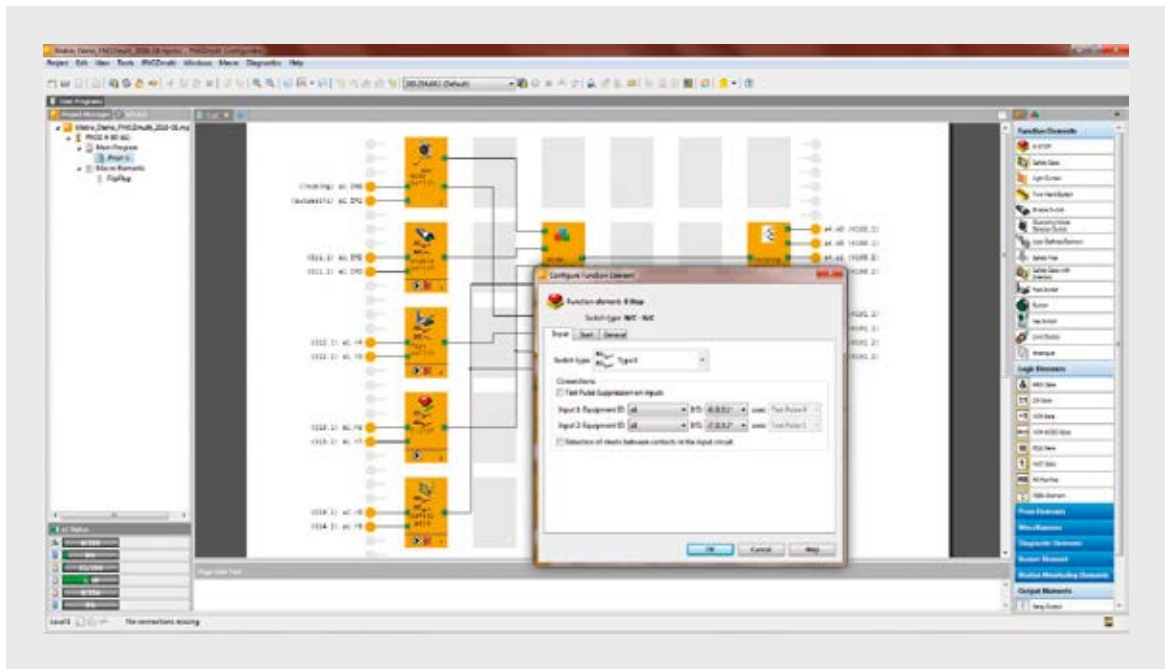

Configure function elements

The parameters available in the “Configure Function Element” window (see figure) essentially mirror the familiar functions from the safety relays. They no longer have to be set laboriously on the device or be selected via jumpers; with the parameter tool everything operates in the simplest way possible. Users will find all the useful, proven elements from the world of the classic safety relays, just represented in a different format. This new configuration method has another quite simple, safety-related benefit: once the configuration has been selected, it cannot easily be modified by unauthorised persons via screwdriver or device selector switch.

Simple configuration of the required input and output elements plus special elements for speed or analogue processing enable users to create a safety controller that suits their own individual needs. Functions can be added or adapted later with relative ease. Users simply select these elements from a list and then create the necessary logic functions.

► 5.2 Configurable safe small controllers

5.2.1 Safety-related and non-safety-related communication

5.2.1.1 Non-safety-related communication of standard signals and diagnostic data

Communication on classic contact-based safety relays is very limited. Simply displaying fault conditions can sometimes prove difficult. Switching to electronic versions already makes communication somewhat easier: LEDs flash, sometimes with varying frequencies, to distinguish between specific malfunctions. LCD displays indicate errors and/or operating states in plain text.

Configurable small controllers offer a whole new set of options here: they can be connected to almost any fieldbus via fieldbus modules. This enables a simple, two-way exchange of signals and information. This produces closer dovetailing of automation and safety and therefore of the whole automation structure. In this case, the fieldbus modules of the configurable small controllers behave just like any other fieldbus subscriber in the fieldbus system. These connections can be used to transfer diagnostic data to any automation system, leading to a significant reduction of plant and machine downtimes.

Integrated, user-friendly diagnostic concepts enable targeted fault detection and remedial action. Using Active-X elements, data can be displayed directly on operator terminals via the Pilz OPC or OPC UA server.

An OPC UA server connection can also be used to link PNOZmulti with the web-based visualisation software PASvisu. All variable from the safe small controller are adopted here. It is therefore possible to generate a comprehensive and convenient overview of plant and machinery, both locally and remotely.

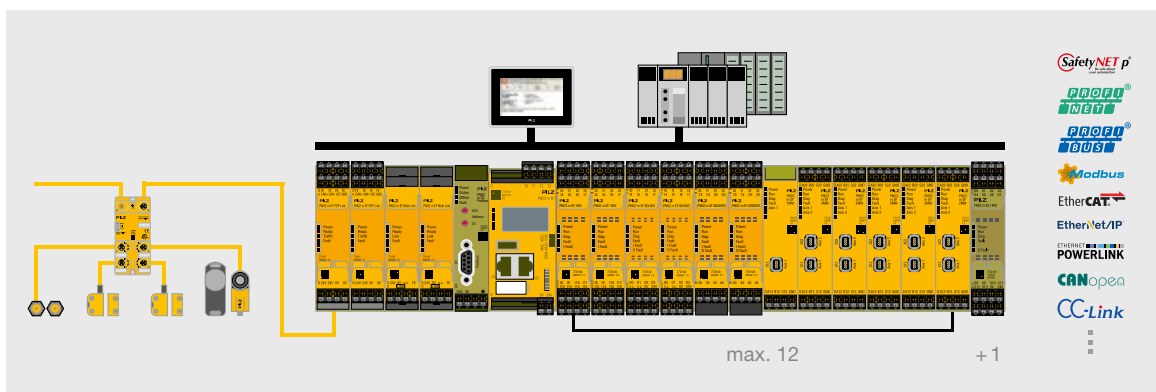

PNOZmulti 2 – for large-scale automation projects in conjunction with the diagnostic solution PVIS, the operator terminals PMI, safe sensor technology PSEN and decentralised periphery PDP67

► 5.2 Configurable safe small controllers

5.2.1.2 Safety-related communication with configurable small controllers

Progressive networking has forced its way up to the level of configurable small controllers. These use special link modules or protocols to exchange safety-related data up to performance level e of EN ISO 13849-1. Safe data transfer using this technology opens up new horizons in the field of configurable small controllers. If several machines are working together in a close network, for example, safety requirements will demand that safety signals are exchanged between the controllers.

Previously, this could only be achieved by exchanging hardware signals. This is a laborious process and is extremely inefficient due to the high cost for each piece of information transmitted. If link modules are used to replace the previous hard-wired solution, the amount of wiring is reduced along with the cost, while the amount of information data is increased.

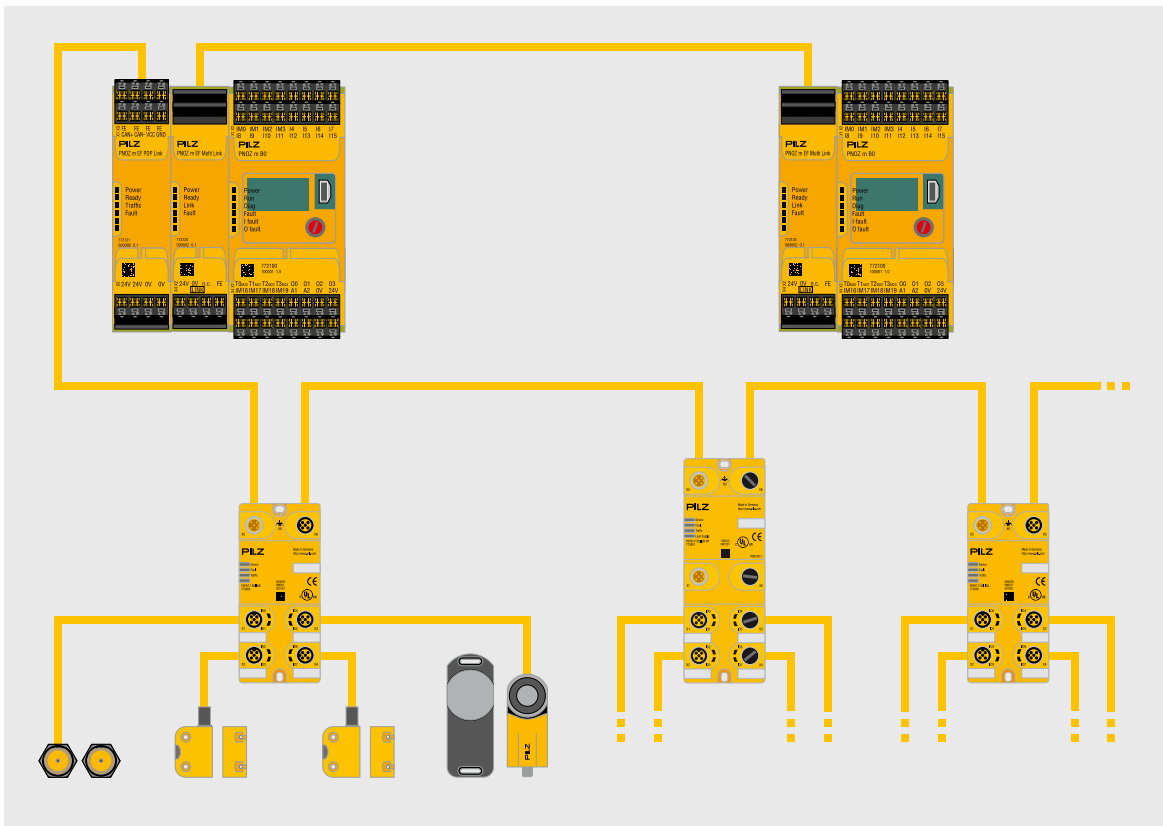

Connection of configurable safe small controllers

► 5.2 Configurable safe small controllers

In addition to these special link modules, more and more Ethernet-based safety protocols are now being used, even in the field of safety controllers. The black channel principle enables the Ethernet network to be used in parallel with automation and safety protocols.

A function and logic element has been developed to transfer safety information; this makes it easy for users to exchange data with the automation system PSS 4000 in complex networks.

Transferring this safe communication into software-based elements or special hardware is probably the most efficient solution that is currently available in networking.

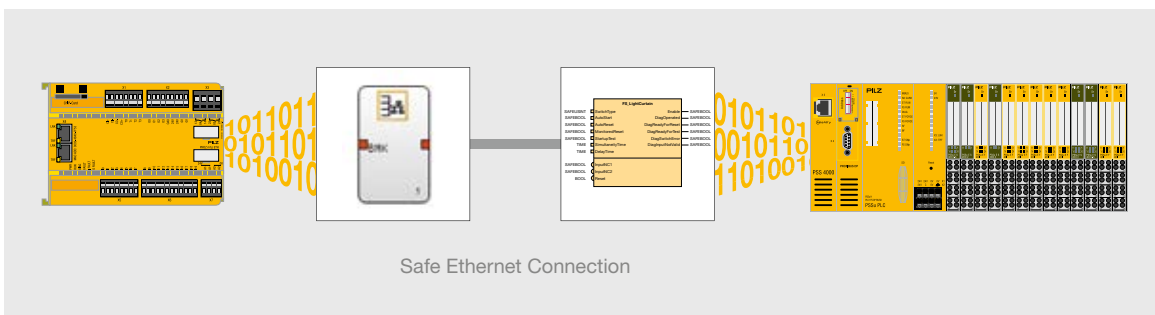

The safe Ethernet connection enables a point-to-point connection between a PNOZmulti base unit and a PSS 4000 device. Up to 48 safe virtual inputs and outputs can be transmitted via this connection.

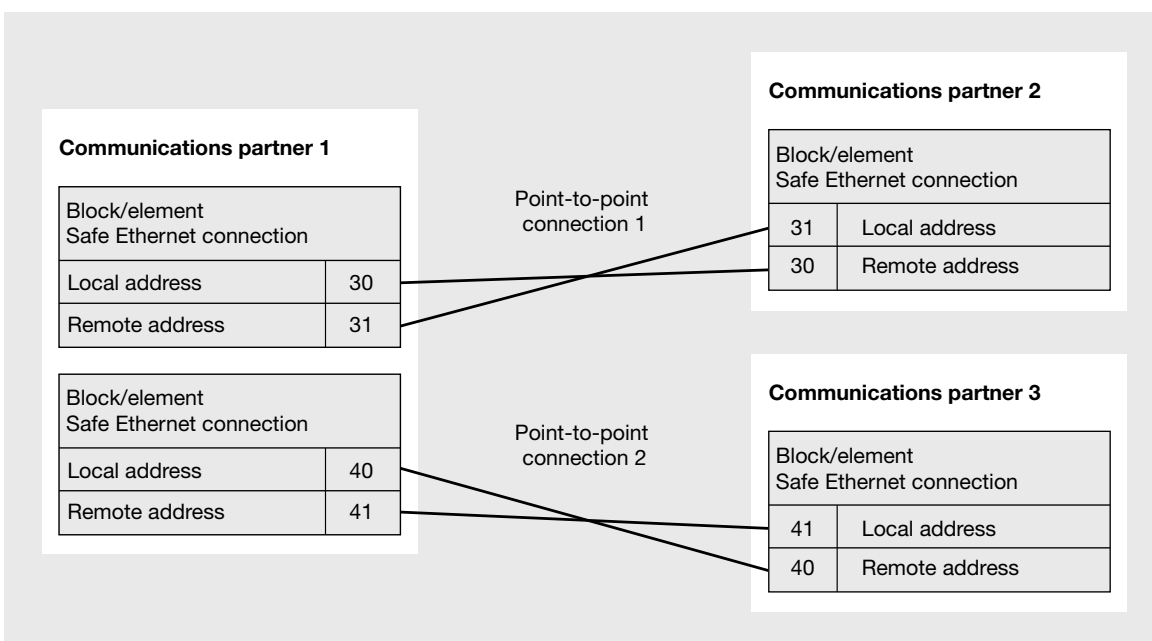

Connection addresses with two point-to-point connections

► 5.2 Configurable safe small controllers

5.2.2 Customer benefits from function and logic elements

Configurable safe small controllers offer a wide range of predefined function elements. These elements form the basis for implementing the safety technology requirements of plant and machinery. The availability of elements for the widest possible range of applications and functions enables users to implement their requirements quickly and effectively.

5.2.2.1 Function elements for muting function

The “muting function” is one of those laborious functions which previously required the application of special relays, but which can now be implemented easily using configurable small controllers. The function is used to automatically and temporarily suspend a safety function, such as a light curtain or laser scanner. It is often applied, for example, to transport material into or out of a danger zone. A distinction is made between sequential and cross muting. Typical application areas include the automotive industry, on palletising of drink dispensing machines, or in the manufacture of stone products (concrete blocks, tiles etc.). Additional sensor technology is used to distinguish between persons and objects.

Example: Sequential muting

Muting phase 1:

- ▶ Material in front of the danger zone
- ▶ Light curtain active
- ▶ Muting lamp off

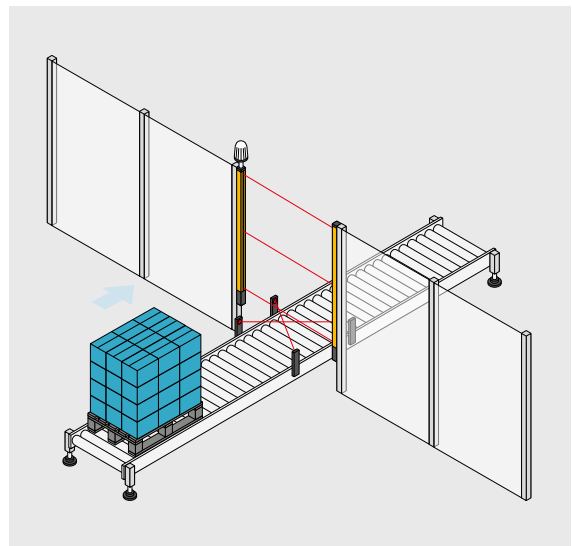

Muting phase 2:

- ▶ Muting sensors 1 and 2 operated
- ▶ Light curtain suspended
- ▶ Muting lamp on

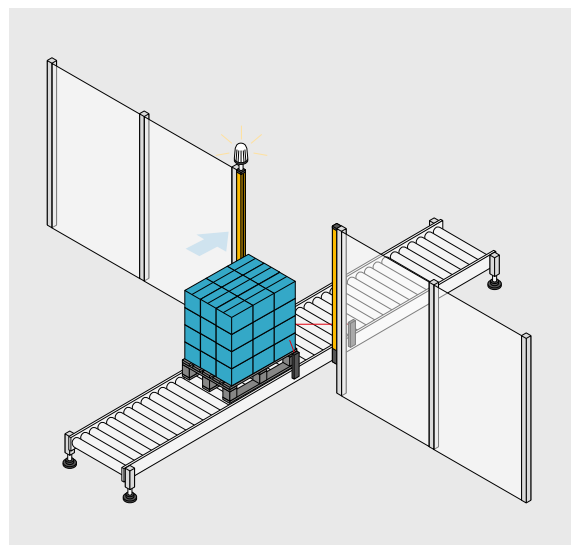

► 5.2 Configurable safe small controllers

Muting phase 3:

- Muting sensors 3 and 4 operated
- Light curtain suspended
- Muting lamp on

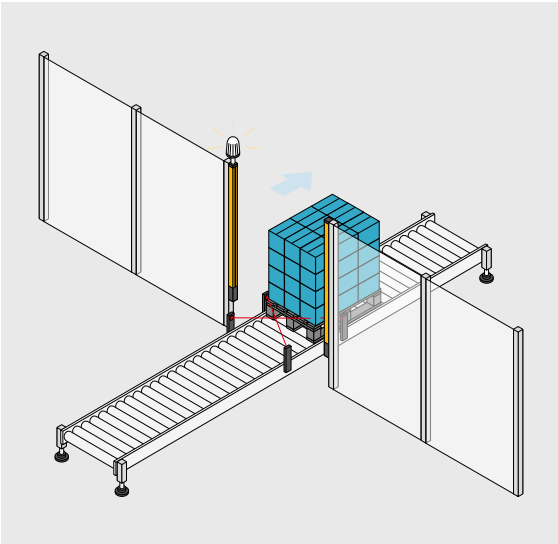

Muting phase 4:

- Muting process ended
- Light curtain active again
- Muting lamp off

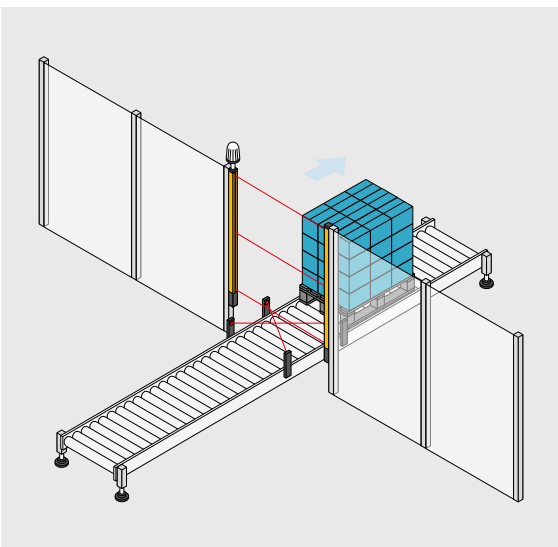

► 5.2 Configurable safe small controllers

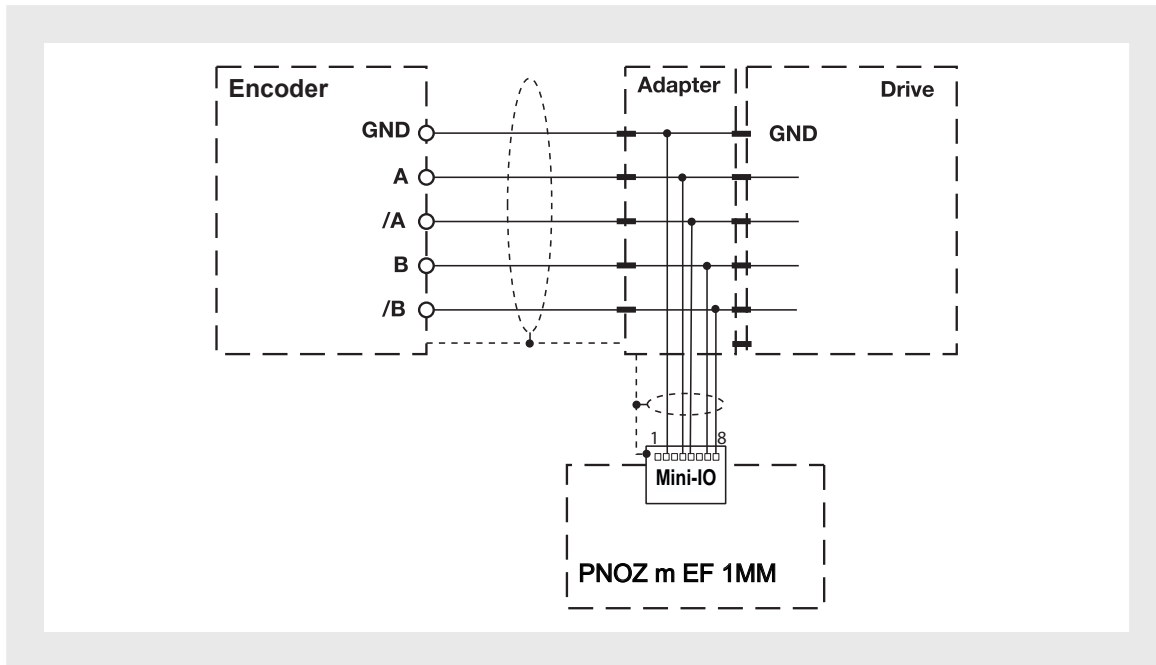

"Listening function" of a standard encoder through the safety controller

5.2.2.4 Logic elements for the drive environment

In addition to general safety functions such as monitoring of safety gates, emergency stop function or light curtain evaluation, configurable small controllers also offer special expansion modules and specific logic elements for advanced options such as the safe detection of movement and standstill on drives. With the speed monitor modules of the PNOZmulti devices, up to two axes are possible per expansion module, each with eight limit values for speed and standstill monitoring and detection of clockwise and anti-clockwise rotation. In this way, motion information can be integrated directly into the safe small controller, irrespective of the drive system you are using.

Monitoring is possible up to performance level d of EN ISO 13849-1 with regular standard rotary encoders. No expensive safe encoders are required. Laborious wiring is no longer necessary thanks to the simple "listening function" of the encoder signals – "tapping" the encoder cable via a T-junction. The direct signal tap on the motor encoder minimises the work involved in the mechanical and electrical design through appropriate adapter cable for the widest range of drives. Speed and standstill detection, including evaluation via customised logic elements, is easily available via plug and play.

► 5.2 Configurable safe small controllers

5.2.2.5 Logic elements for safe analogue processing

In the past, processing analogue signals safely using safe small controllers was as good as impossible. Only the integration of special expansion modules and the availability of customised logic elements has made safe analogue processing possible. In a similar procedure to that of the drive environment, configurable small controllers can be used to evaluate sensor information from the analogue process environment. This may relate to process conditions such as fill level, position, temperature or pressure for example; there's practically no limit to the extended application options. For analogue signals it is also possible to define limit values, threshold values or value ranges within which a measured value may move; this is done through configuration of the module or by setting parameters in the logic element. Reliable monitoring therefore becomes a reality; all values can be evaluated and further processed.

Example: Range monitoring 4 ... 20 mA current loop

With range monitoring, the first step is to define the permitted value range. Depending on the selected condition ("greater than" or "less than"), the output for threshold value monitoring is set to "0" if the recorded value exceeds or drops below a range limit.

Two range limits are to be defined in this example:

- ▶ $I < 3 \text{ mA}$ monitors for open circuit and
- ▶ $I > 21 \text{ mA}$ monitors for encoder error

	Error if		Comment
	Condition	Value	
R1	<	3 mA	Open circuit
R2	>	21 mA	Encoder error

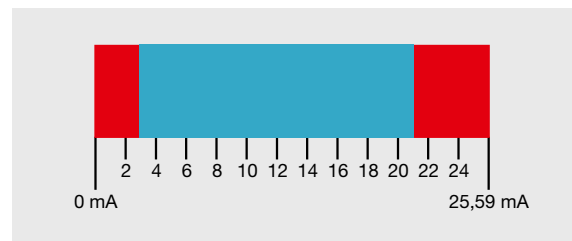

Example: Monitoring the position of a control valve via range monitoring

Control valves in process technology, e.g. to control flow rates, are generally controlled in analogue; feedback on the valve position is also analogue. Without safe analogue processing, until now, only special switches have been able to evaluate the position signals from valves. PNOZmulti allows you to set as many valve positions as you like and to monitor compliance, safely and reliably.

► 5.3 Safety and automation

5.3.1 Overview of safety controllers

Safety controllers essentially came about because of the desire to integrate safety through programming, in a similar way to that of a PLC control system. It's no surprise then, that safety controllers are following the example of the PLC world. Centralised systems came first, followed by decentralised systems in conjunction with safe bus systems. The programming followed the same pattern, except that the instruction set was drastically reduced from the very start. Additionally, simple languages such as IL (Instruction List) or LD (Ladder Logic/Ladder Diagram) were used. These measures were taken for reasons of safety, for the opinion was that limiting the programming options would minimise the errors made in generating the program. Initial systems clearly focused on processing safety functions. Although even at the start it was possible to program the safety controller for standard automation, in practice this application found very limited use. In the meantime, however, a growing number of limited high-level languages such as Structured Text are being used in programming.

Safety-related features aside, there is little to distinguish safety controllers from standard automation control systems in terms of their actual function. Essentially a safety controller consists of two PLC controllers, which process the application program in parallel, use the same I/O process image and continuously synchronise themselves. It sounds so simple, but the detail is quite complex: cross-comparisons, testing of the input/output level, establishing a common, valid result, etc. are all multi-layer processes, which illustrate the internal complexity of such systems. Ultimately, of course, the user is largely unaware of this; with the exception of some specific features, such as the use of test pulse signals to detect shorts across the contacts, modern systems behave in the same way as other PLC controllers.

Structure of a safe control system:

- ▶ Two separate channels
- ▶ Diverse structure using different hardware
- ▶ Inputs and outputs are constantly tested
- ▶ User data is constantly compared
- ▶ Voltage and time monitoring functions
- ▶ Safe shutdown in the event of error/danger

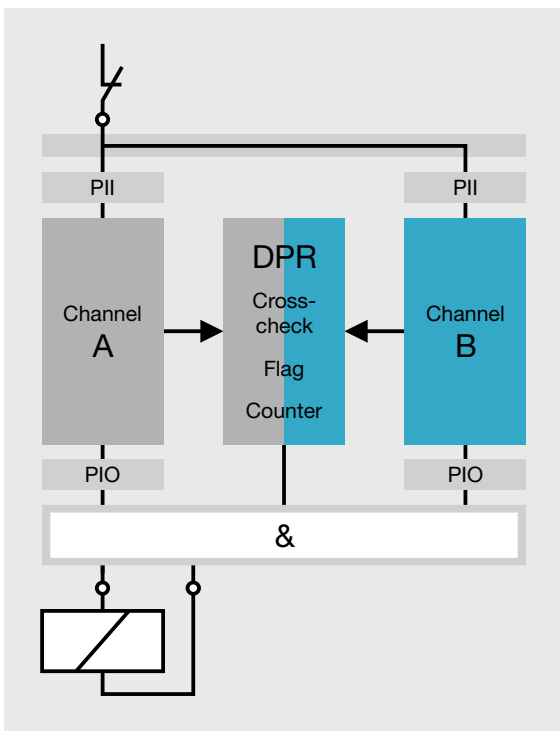

Elementary structure of a safe control system

► 5.3 Safety and automation

5.3.2 Integration within the automation environment

Cycle times are becoming ever shorter, while productivity and the demands on plant and machinery control systems are increasing. In addition to the technical control requirements, the need for information regarding process and machine data is constantly growing. As a result, communication technologies from the office world have made their mark on control technology. One consequence of this trend, for example, is the prevalence of Ethernet-based bus systems in automation technology, right down to field and process level.

Previously safety technology was characterised more or less as a monitoring function and was incorporated as such into the automation chain. The process controller dominated and thereby defined the actual process stages. As a “monitoring instrument”, the safety controller either agreed or disagreed with the decisions of the process controller. The figure overleaf illustrates the principle.

Monitoring is limited to safety-relevant control functions, as is the enable. Process outputs without a safety requirement are unaffected. A distinct benefit of such a procedure is the fact that the tasks, and therefore the responsibilities, are clearly separated. A separate system is responsible for the design and monitoring of the safety technology; another separate controller manages the machine and the process. This way it is possible to guarantee the absence of feedback: changes made primarily in the standard control system will not affect the safety controller. This is an essential safety requirement of a safety system.

The division of duties also has a number of positive aspects: on the one hand, it increases overall performance, because each unit simply concentrates on the matters for which it has been designed and configured. Productivity increases do not just impact positively on the output of the plant or machine: they can also be beneficial in terms of handling, if faster reaction times enable safety distances to be minimised, for example. On the other hand, separation can also be used to transfer responsibility for the individual systems to different individuals. That helps both sides, because everyone can concentrate on the task in hand.

► 5.3 Safety and automation

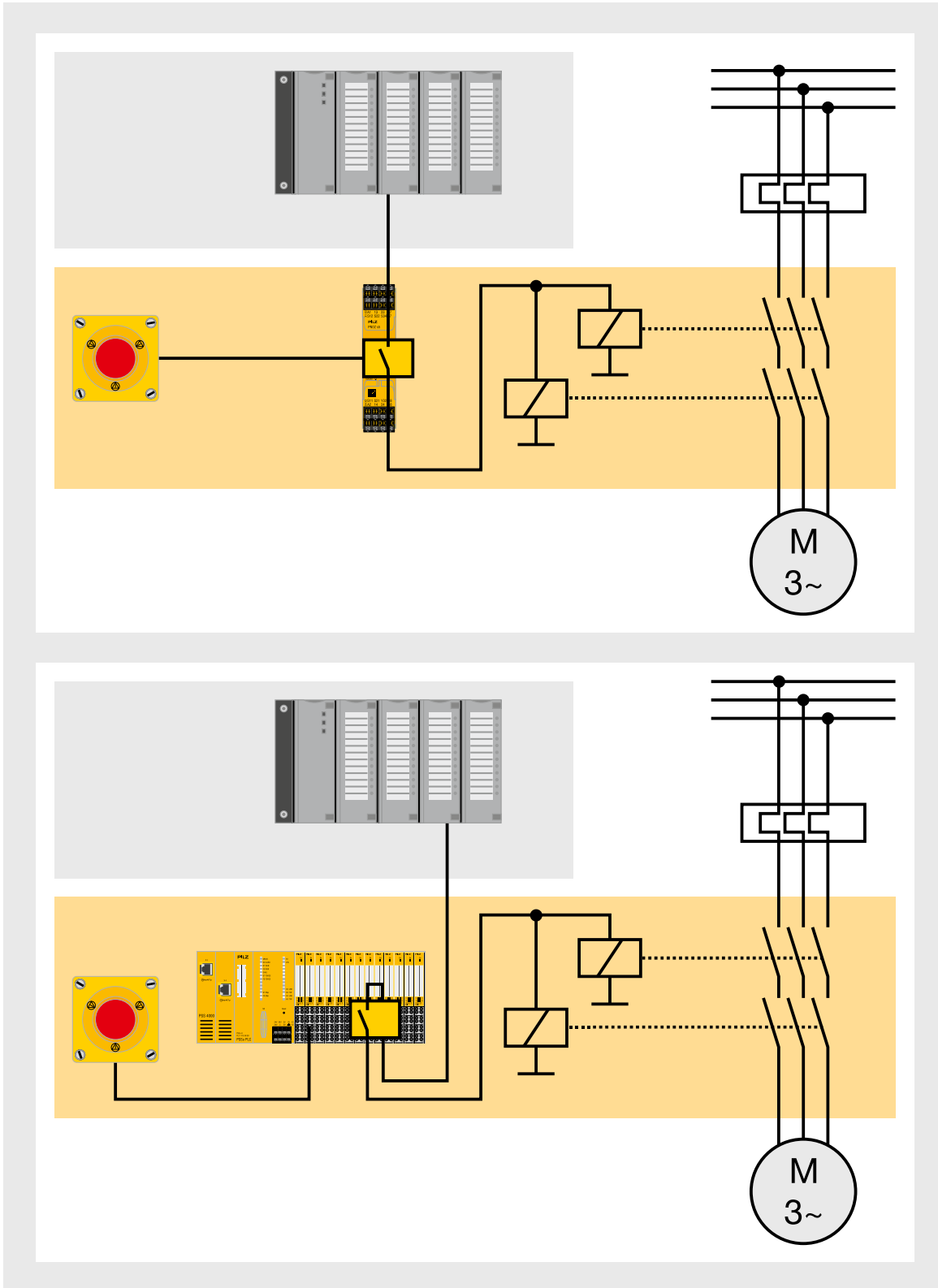

Enable operating principle, with safety relay or safety controller

► 5.3 Safety and automation

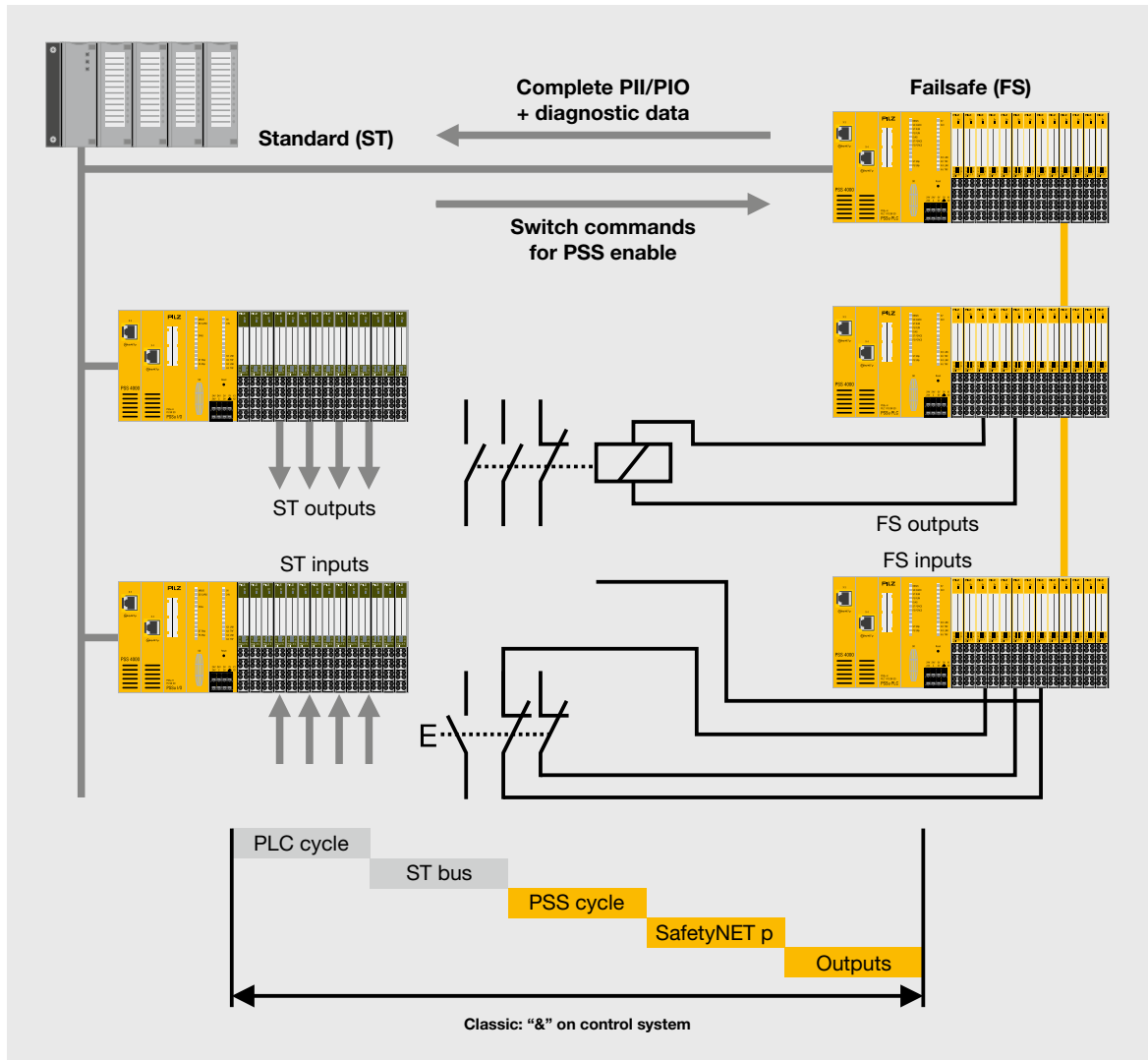

Circuit diagram for the enable principle

5.3.3 Safe decentralisation and enable principle

As explained already, in many cases safety technology follows the developments made in standard control technology. The benefits from transferring the input/output level to the field via decentralisation have resulted in the same process being applied to safety-related inputs and outputs. This was followed by the development of a safety bus system, which not only allows field inputs and outputs but also a safety-related connection between safety controllers.

The diagram above illustrates a typical application in which the enable principle has been implemented. The safety controller switches the safety-related outputs, and the standard PLC transfers the switch command for the corresponding output to the safety controller via fieldbus. This retrieves the switch command from there and inserts it into the output's control program as an AND function. Modern controllers combine the safety function and the standard function in one device. The data is thus transferred within the overall controller between the safety section and the standard section. The time for running the data over the fieldbus is no longer required, thereby considerably shortening the reaction times. The fieldbus now transfers safety-related and non-safety-related data to decentralised modules in one medium.

► 5.3 Safety and automation

5.3.4 Function blocks in safe controllers

Function blocks for safety-related functions are the key to the success of safety controllers. Although initially they were more or less an image of the functions and properties found on safety relays, gradually the range has been developed to include elements for special uses such as press applications or burner management. Today, function elements are available for almost every conceivable safety-related application. All of these have been tested by notified bodies and offer users optimum safety for everyday use.

The concept of function elements was originally intended for the safety controller, but was then developed to form configurable logic elements for configurable small controllers as described, making applications even more customer-friendly. The principle of using configurable logic elements is also part of a continually developing programming environment for the safety controllers. The user can choose between classic programming, e.g. in IEC 61131, and a configuration similar to that of the configurable small controllers.

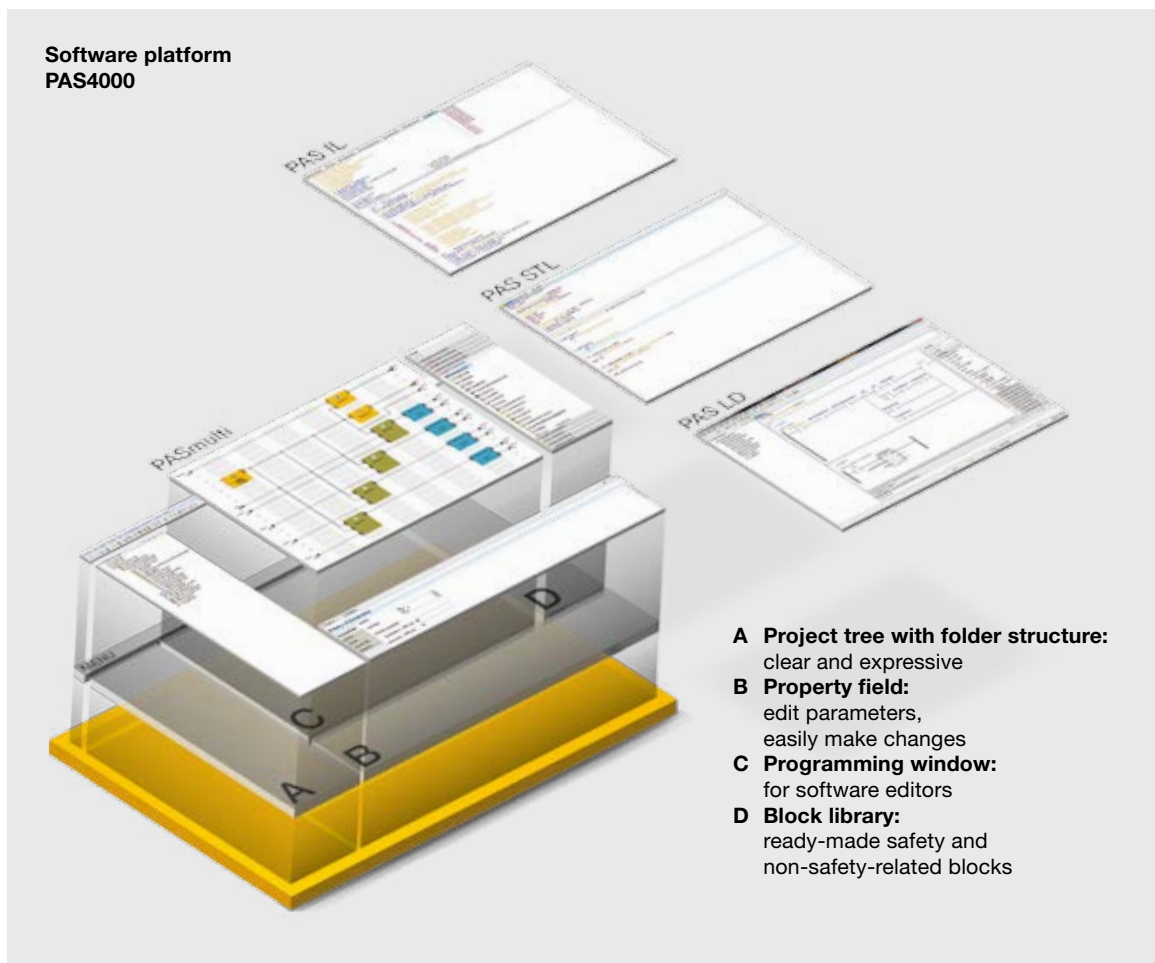

Modular software for controlling, programming and monitoring using software platform PAS4000 as an example

► 5.3 Safety and automation

5.3.5 Mission time with safety functions

What happens with components in safety functions (designed in accordance with EN ISO 13849-1 or IEC 62061) at the end of the mission time (T_m)?

The duration of use of the relevant modules has been an issue since the application of EN ISO 13849-1 for design and validation of safety-related control functions. The standard specifies a period of 20 years as the default value for safety-related components. However, it is also possible to use components with a shorter mission time, provided the machine's accompanying documentation clearly refers to this component and the need to exchange it.

Even if the issue is largely excluded at the moment: on long-lasting machines, the time will come in which the configured mission time has elapsed, but the machine is to continue in use. In this case, safety-related integrity can only continue to be guaranteed if the relevant components are exchanged. By this time the original machine manufacturer will probably have no more obligations regarding the machine, so responsibility passes to the operator. The relevant components must be identified and replaced. The new components must have similar or better safety-related characteristic data (PL, SIL, $B10_d$, $MTTF_d$, etc.). This process can be made easier if the original machine manufacturer provides this data from the outset (e.g. by verifying the design using a calculation program such as PAScal). In this situation it is conceivable that components will be exchanged that appear perfect from the outside and continue to perform their control function without difficulty. Nonetheless they need to be exchanged because the probability of a dangerous failure has risen to beyond an acceptable level.

In theory it is possible to have the manufacturer inspect the used component, for example, and maybe repair it in such a way that a new mission time (T_m) begins. However, this approach is rarely cost effective and only ever on very valuable components.

Even IEC 62061 recognises a similar parameter, namely the "proof test interval". At the end of this interval, the component must undergo a proof test to examine its further usability. The situation is comparable to that in accordance with EN ISO 13849-1, only the mission time is not fixed at 20 years but rather specified individually by the manufacturer, thus making it more difficult to trace.

5.3.6 Use of used components

In general, the use of used components is also to be considered. This is only reasonable for high-quality components that still have a considerable residual value that justifies the additional work. If used components are to be used in new safety functions, it's important to estimate the proportion of mission time (T_m) that has already elapsed and how much remains. Other characteristic data, particularly the $B10_d$ value on components that wear due to operation, can be partially utilised. Such components can only be used if their previous application has been traced and documented. These (reduced) values must then be used in the calculations when validating the new safety function.

► 5.4 Using safety controllers to achieve safe control technology

5.4.1 Overview

In which direction is safety technology developing? Which control systems provide the highest user benefits? How will the various disciplines of safety, control, motion, CNC and visualisation work together in future? Will it be possible to implement economical solutions despite the increasing complexity? Even in future there will be a number of different approaches to take to resolve requirements. One potential approach is to modularise plant and machinery into functional units. This is already happening today, albeit primarily for the mechanical part of plant and machinery. This approach has only partially been used in control technology as yet.

Whether the issue is safety-related or automation functions: the demands on plant and machinery continue to grow, so there's an increasing need for techniques that will allow applications to be well structured and therefore manageable. The requirement for minimum effort and associated cost reductions is increasingly the focus. The aim is to reduce engineering times still further.

The graphic below illustrates the compromise that has previously been reached between minimum costs, maximum quality and rapid implementation:

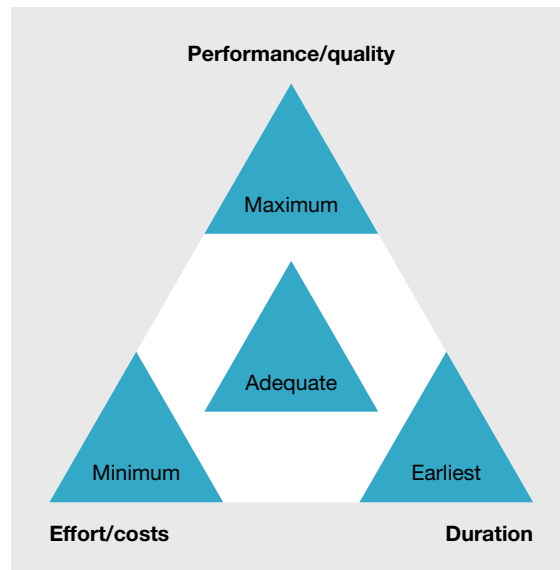

However, excellent support during the engineering phase, through an appropriate programming model, a user-friendly programming environment and an extensive library, can lead to higher quality in shorter time and at a lower overall cost.

► 5.4 Using safety controllers to achieve safe control technology

5.4.2 Structures of safe control technology

The model of safety technology as a pure “monitoring function” is changing drastically: safety technology may have been almost exclusively associated with emergency stop, safety gate, light curtains and interlocks for a long time, but it would now be unthinkable not to regard the issue of safety on drives, for example. Other areas will include safe pneumatics and hydraulics. Applications will emerge from areas which are not yet the focus of our attention, but one thing is clear: safety is an integral part of the overall plant and machine function, so it must be considered appropriately, right from the start. In simple language, safe control technology means: make the control function safe! Safe control technology becomes reality

when safety enjoys the same mechanisms, the same handling and the same flexibility as the standard section, at all levels of automation technology.

This does not mean that safety and automation functions have to be combined inside one device. What’s important is that they work together to process tasks as a system, without impeding each other. Each device, each controller, should do what it does best. The system’s backbone is an extremely powerful bus system, which manages data traffic in the background. The result of this technological development is a system which uses the intrinsic benefits of technology controllers. For example, it makes no sense for a safety controller to have to carry out motion functions when that’s a specific task of the motion technology controller.

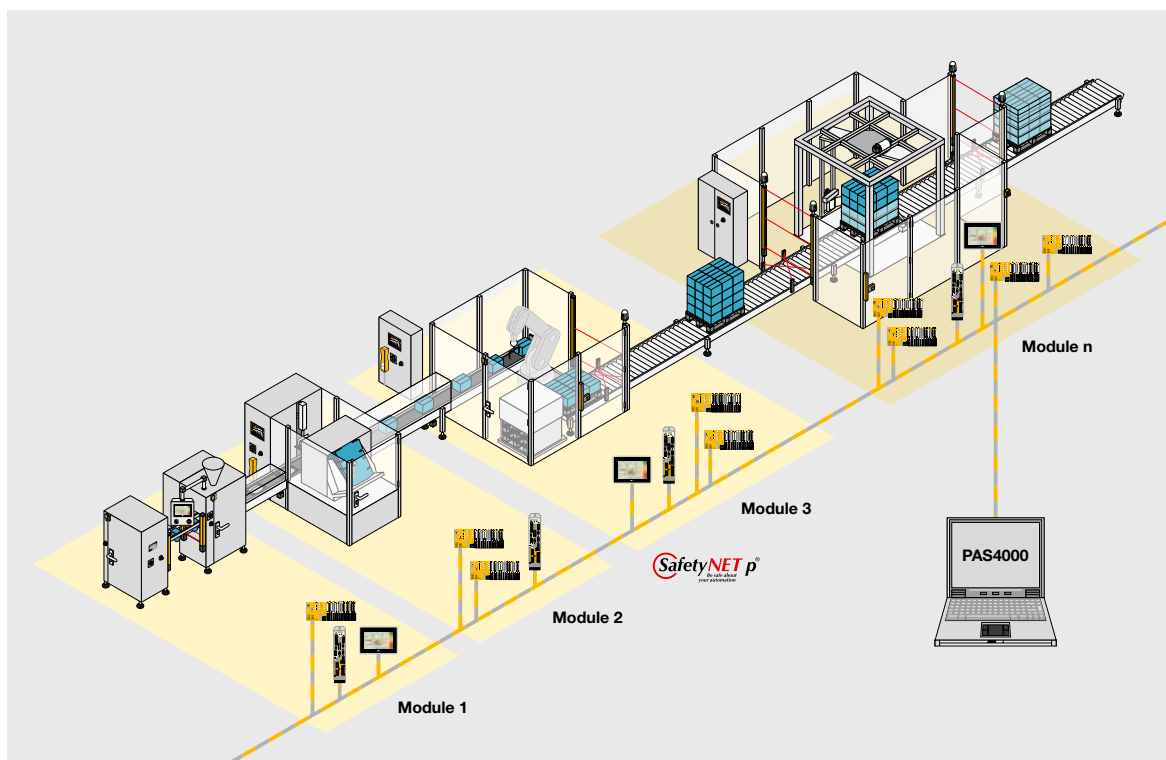

Safety and automation control functions combined in one system

► 5.4 Using safety controllers to achieve safe control technology

Ultimately however, this means that all the controllers have to be able to share access to the same data, without the user being required to organise it this way. The system must perform this task automatically in the background. In future, even the tools must have the same look and feel, plus standardised handling. Whether it's motion, control or visualisation: handling of the various functions and tasks must be seamless.

5.4.3 Modularisation of the automation function

Modularisation as an approach to solving the control technology requirement of the future ultimately involves division of the control technology into corresponding units or modules, and decomposition right down to the technology functions.

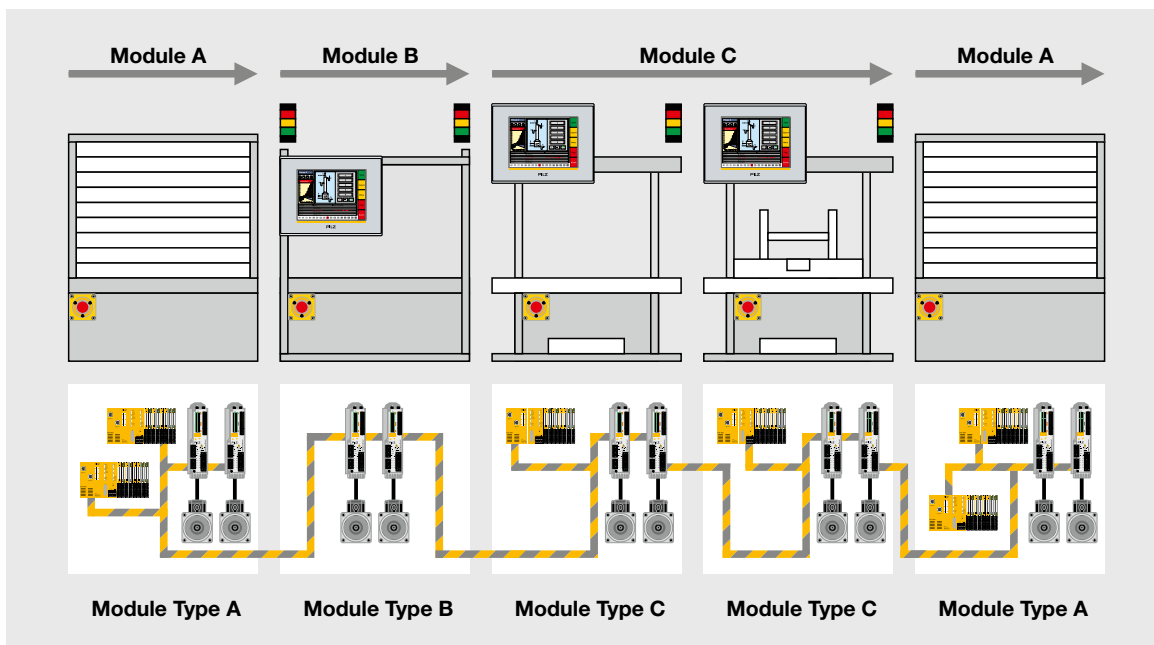

Modularisation of a machine and distribution of tasks across various control systems

Whatever can be decomposed mechanically can also be decomposed into single parts or components with regard to automation. A components-based approach must not be limited to individual stations (such as modules A to C in the figure, for example), but must extend right down to the individual function units (known as mechatronic units). Future applications will be implemented much more effectively if comprehensive libraries can provide these units as reusable component blocks.

Even when division into modules and mechatronic units makes sense, it's important not to lose sight of the overall picture: programming models that keep the units together and represent them as a whole are a much greater benefit to customers than those that merely provide components with interfaces and ultimately expect the user to look after these interfaces.

► 5.5 Safe control technology in transition

Sometimes safety technology appears complex and confusing, but behind it is the ongoing quest for simple “formulas”: safety must be simple, clear, traceable and verifiable. As a result, safe control technology leaves little room for an unconventional approach to solutions; it is almost by definition a conservative part of control and automation technology. Innovative trends or flows are mostly introduced after somewhat of a time lag. This mindset is also manifested in the current perception that, if a fault occurs or safety is called upon (for example if the E-STOP function is operated), safety technology must always shut down safely, by electromechanical means wherever possible and without using any additional electronic components.

What is this perception based on? Safe control technology is intended to protect man from all hazards emanating from plant and machinery. As such, it is informed by norms and standards like almost no other sector. Last but not least, if regulations and specifications are presented in a way that is transparent, making it simpler to understand how they are implemented, this also helps to achieve safety.

The usual formulas and perspectives may still apply and essentially still make sense, but safety controllers are also undergoing a massive transition in the course of general technological progress. Even in the past, safe control technology has continuously adapted to control-related circumstances: how else would we have today’s safety solutions, which would have been totally unthinkable in the eighties and would not have conformed to the standards at that time because only electromechanical solutions were permitted? Electronic safety solutions only came into use gradually following extensive test procedures carried out by notified bodies (TÜV, BG, etc.). Modern manufacturing techniques require new technical approaches; process and manufacturing cycles are constantly changing. Clearly, safe control

technology must keep pace with developments in the automation technology sector. Customers expect innovative products and solutions with integrated safety concepts that increase productivity, support efficient work processes and create additional benefits.

5.5.1 New safe control technology requirements

What are the challenges facing safe control technology today? Current requirements for greater flexibility in configuration and programming or for increased communication, for example, are already being taken into account. There are other requirements, however, which cannot yet be identified explicitly, nor do they have a name. Henry Ford once said “If I’d listened to my customers I wouldn’t have built cars, I’d have bred stronger horses”. This illustrates the point that successful developments should not be geared solely at superficial needs but must always deal with the core requirement. Far-sighted vision is required if innovative products and solutions, in the true sense of the word, are to be the end product. If you transfer this insight to safe control technology it is clear that the formulas commonly used today cannot solve the tasks of the future; companies need to offer new solutions.

Even today, in many companies safety operates by removing power to every drive, even the whole plant, once a protected area has been accessed. With increasing productivity requirements, however, it must be possible to access defined detection zones in a plant without having to halt the entire production process. At the same time the safety of the operator must be guaranteed. That’s why the demand is for intelligent, dynamic safety solutions. In future, to react to a safety-related event with a total shutdown can only be regarded as a last resort.

► 5.5 Safe control technology in transition

With some justification, a whole new generation of safety controllers is expected from safe control technology manufacturers in future. Compare it with your car, where assistance functions are increasingly used to help drivers and offer additional safety (features such as distance monitoring and automatic speed reduction); in the same way, useful, extra safety-enhancing features will increasingly make their mark in mechanical engineering. An example from forming technology, where servo presses are becoming increasingly important, clearly illustrates the changed requirements: on conventional presses a mechanical rotary cam arrangement was enough to control the safety of the stroke movement, but the motion sequence on servo presses is fundamentally different. A press stroke is no longer the 360° rotation of an eccentric cam but a pendulum movement between variable angle settings. Previously well-tried procedures can no longer guarantee safety on such applications; the demands on the evaluation device are much more complex than before.

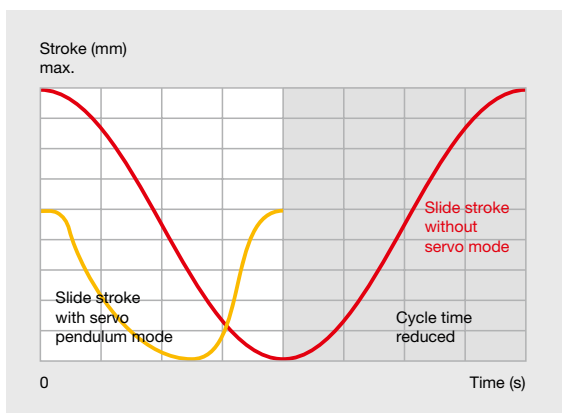

Slide stroke with and without servo mode

The graphic examples are intended to show that in future, safe control technology will need to make wide-ranging calculations in order to meet the specified requirements. Safety controllers must be able to record, process and output complex measured variables. The necessary means to do this are significantly different to anything currently available. It involves not only the sensors and actuators, but above all the processing logic functions, for which simple instruction sets are no longer sufficient due to the increased requirements. To summarise, plant and machinery processes are becoming more complex and dynamic due to the demands that are placed on them. Safe control technology of the future must take these changed requirements into account.

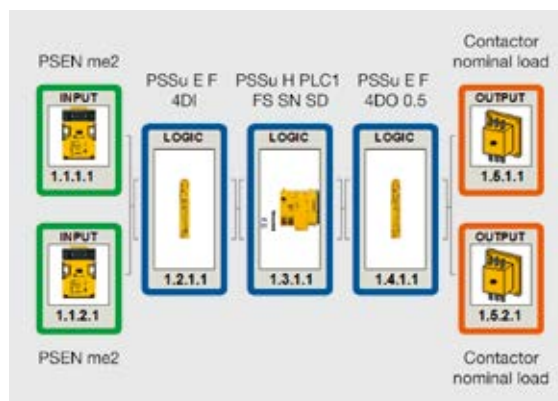

Safety function in accordance with EN 13849-1 with sensor, logic and actuator

► 5.5 Safe control technology in transition

5.5.2 Complex yet simple – no contradiction

The classic, widespread view of safety technology today revolves mainly around safety functions such as those illustrated below. Common functions are those such as emergency stop, safety gates, two-hand control, operating mode selection, valve control, monitoring the direction of rotation or rotary cam arrangement; these cover the majority of the required safety functions – basic functions that are required in this or a similar form in almost all machines.

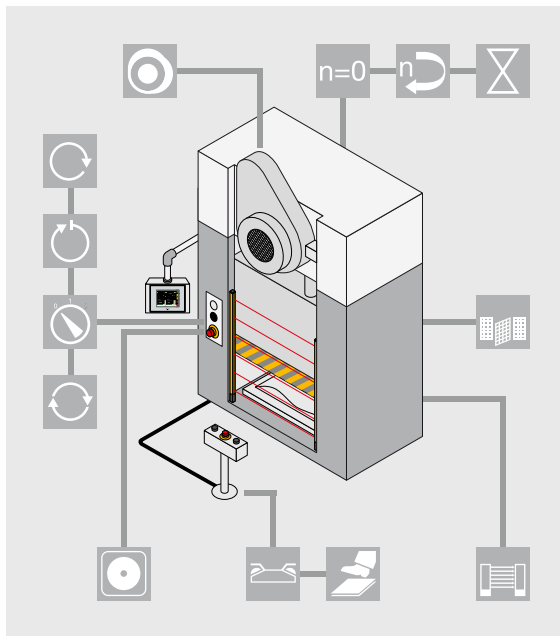

Safety functions on an eccentric press

Where safety on plant and machinery is limited to basic functions, there will still be a requirement in future for simple safety controllers, on which a manageable number of safety functions can be implemented simply. That is one of the strengths of configurable small controllers such as PNOZmulti: programming could not be simpler, using graphic symbols and drag and drop. This has now become the state of the art; indeed it has practically been the market standard since the turn of the millennium. To date, PNOZmulti has been both role model and technological forerunner within this device class.

5.5.2.1 Configurable safe small controllers continue to develop

Because the software tool and hardware were so easy to handle, applications that were originally the reserve of “genuine” high-performance safety controllers have gradually been migrating to the configurable small controllers. In principle, that does not present a problem, provided the devices meet the requirements. However, the user is increasingly confronted with the fact that the small controller is reaching the limit of its capabilities. That’s because wide-ranging configurations can be developed to such an extent that even the programmer is at risk of losing oversight. At this point a contradiction can quickly arise: the more you add to the functionalities reproduced in the configurable small controllers, the more you lose oversight and the benefit of simple usability. But the latter is exactly what the user values.

► 5.5 Safe control technology in transition

5.5.2.2 Latest generation configurable safety controllers

What distinguishes the configurable controller PSSuniversal multi, part of the automation system PSS 4000, from established devices such as the PNOZmulti? The control systems PSSuniversal multi are significantly more powerful than the configurable safe small controllers and constitute a whole new device class of “configurable safety controllers”. PSSuniversal multi differs from its predecessors in two key areas: the ability for expansion with additional data types is a fundamental feature. The devices can not only handle Boolean variables but can also process any form of data type, just like “fully fledged” controllers. The graphic options have also been extended so that complex composite data structures can be displayed graphically on individual lines in the Editor. This promotes clarity, without losing important information.

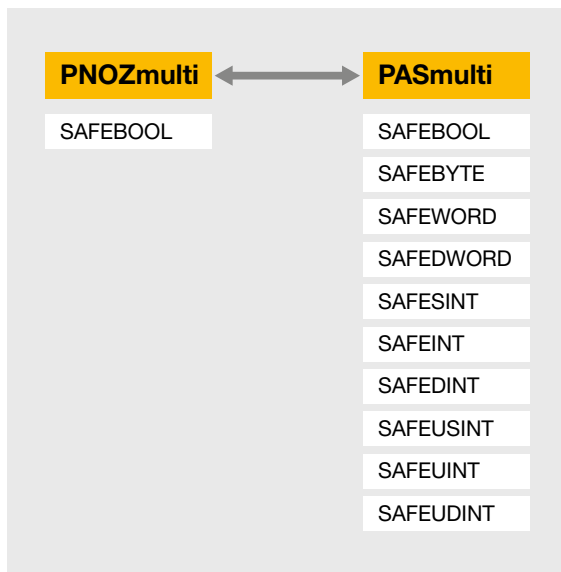

Comparison between PNOZmulti and PSSuniversal multi data types

Another fundamental change concerns the program structure. From the perspective of a PLC controller it is customary for programs to have a hierarchical structure. Programs contain function blocks, which in turn call up functions or elements. A feature of configurable small controllers is that the program is displayed on a single plane. To date it has not been possible to reproduce the hierarchical structures familiar from PLC controllers. It is a sensible solution for simple applications, indeed it has contributed to the success of this device class. However, this type of programming soon becomes confusing when applications are more complex.

Now this feature has been added to the configurable controller PSSuniversal multi: program sections can be combined into one block, making the program clearer, without losing any of the information contained in the program section. If a function is created in the customary “flat” format, it can be selected and merged into a new block. The new element “inherits” all open interfaces as its external interface and can be opened, expanded or modified by double-clicking on it. As a result it is possible to view the element’s internal structure at any time.

► 5.5 Safe control technology in transition

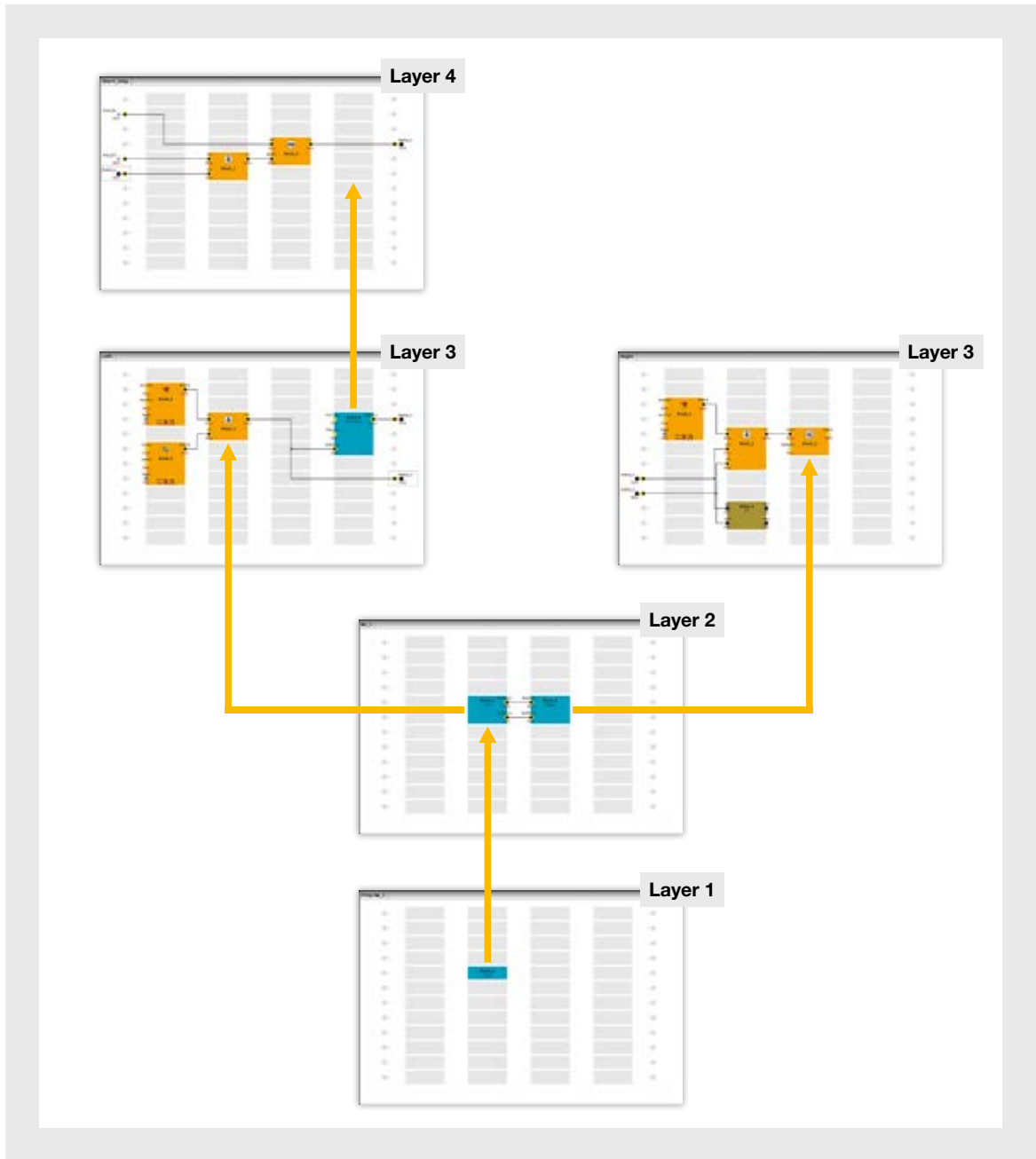

Hierarchical structuring of the controller PSSUniversal multi from the automation system PSS 4000

► 5.5 Safe control technology in transition

5.5.2.3 Integration of automation and safety technology

Previous safety controllers are characterised primarily by the ability to program them freely, in a similar way to a standard PLC. However, there are some restrictions. To ensure that programs remain clear and understandable, on most systems the instruction set and/or number of available editors is restricted. This hasn't been a problem, and indeed isn't a problem, provided plant and machinery only require simple safety measures. However, a structural transition is currently taking place regarding safety technology requirements: processes are becoming

increasingly dynamic, there is a greater need for controlled access to the process and productivity requirements are higher, so safe control technology is gradually changing as a result. In the future, the previous strategy of shutting down safely when the safety function is called upon or when an error occurs will no longer be acceptable. Safe control technology must open up to innovative processes, as currently illustrated by examples of safe drive functions.

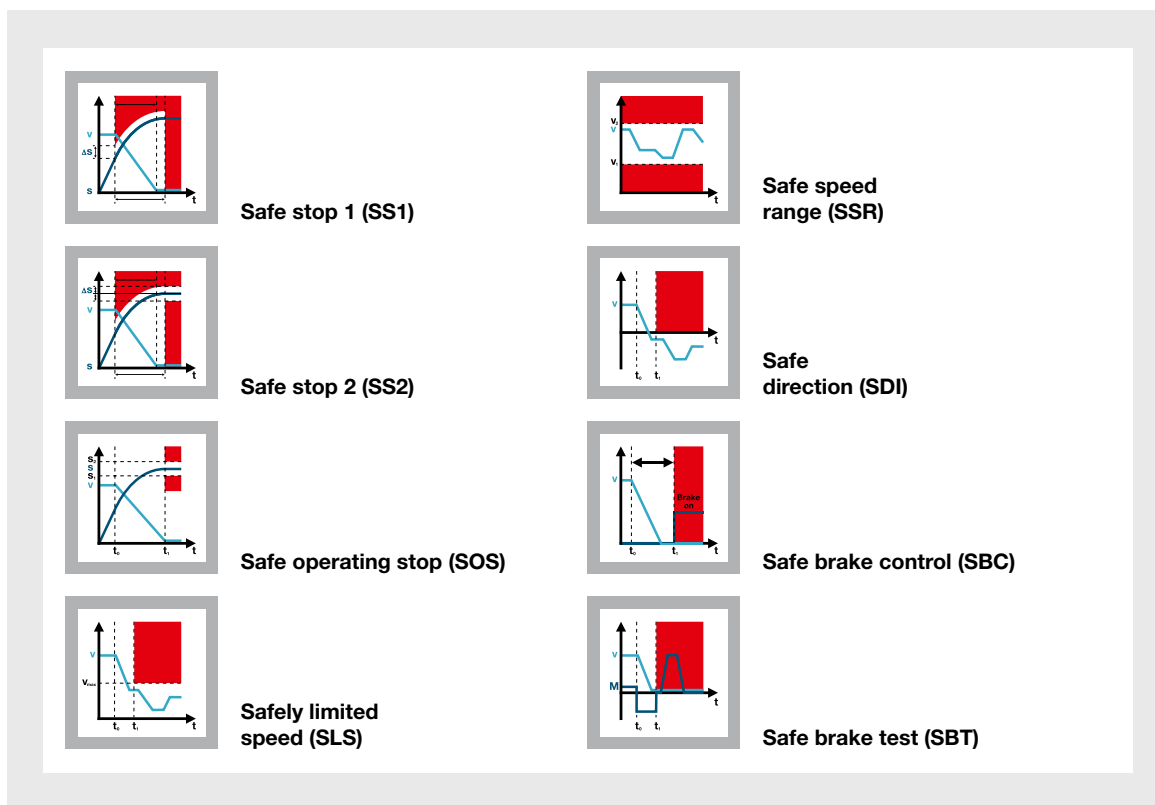

Drive-integrated safety with PMCprotego DS

► 5.5 Safe control technology in transition

But that's just the beginning! Step by step, safe control technology needs to become a permanent feature of automation technology, as is already the case with drive technology with dynamic speed or standstill monitoring. Future safety concepts will need to be much more dynamic, including functions such as torque monitoring, based on the position of one or more axes. The available safety controllers will only partly satisfy these new requirements. Instruction sets will be required that can meet the need for dynamisation of safety functions. And yet programming will still need to be built on simple, manageable base elements that enable a safe programming procedure, as required by the IEC 61508 standards, for example.

Ultimately, modern safety controllers offer a sensible combination of the programming procedure from a PLC and the configuration benefits from the "configurable small controllers" device class. Specifically this means that today's safety controller needs to have a large number of editors. The "instrument" that the user is handed shouldn't span only one octave, but if possible should cover the whole "audible" range. Care should be taken to ensure that the editors also meet the needs of the various industries and target groups. Complex safety functions should be capable of being created and tested in a high level language. After the test phase it must be possible to convert to a graphic display.

► 5.5 Safe control technology in transition

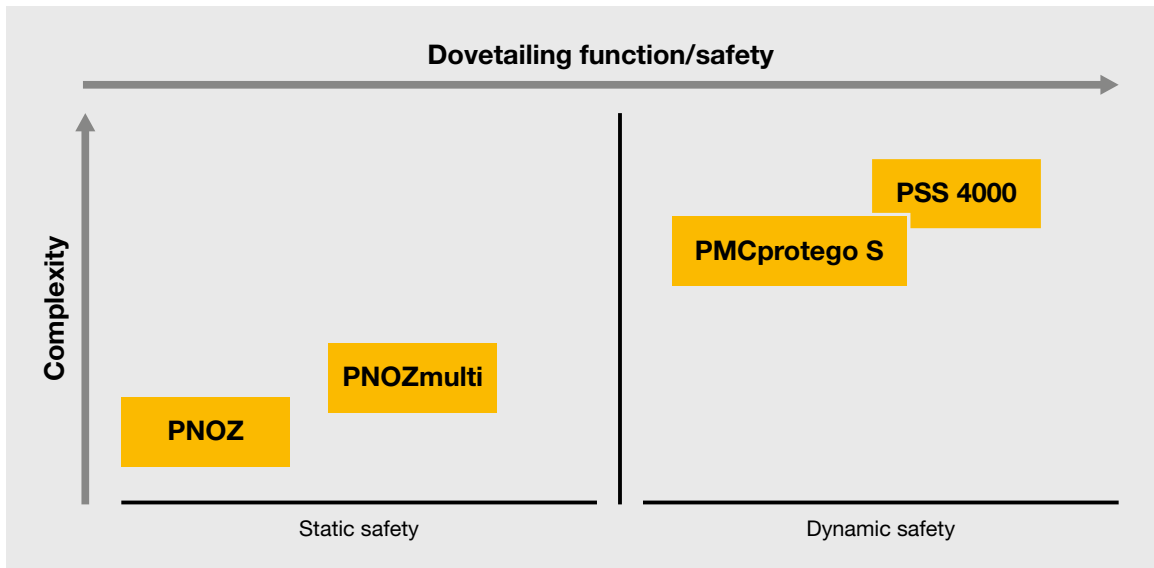

Static and dynamic safety

5.5.3 From static to dynamic safety

Changes are happening at system level as well as device level. The signs are beginning to emerge in the safe drive technology sector. Previously, the safety function was connected to the controller but now it is distributed, i.e. the function migrates to the local function controller, for example the drive. At the same time, separation of the safety and control functions is becoming increasingly fuzzy; the control function could ultimately be safety-related. Looking at today's plant and machinery it is clear that not only have safe automation requirements changed, both in the number of safety functions and the way in which they are linked, but that the desire for more flexible solutions continues to grow. Why is this? The main factor behind what have sometimes been major changes in mechanical engineering over the past few years has been the trend of replacing mechanics with electronics. In addition to economic considerations, this has also brought new degrees of technical freedom, which are now reflected in the safe control technology requirements.

In the past, safety was primarily influenced by static events such as the operation of an emergency stop device, the opening of a safety gate or the interruption of a light curtain, but the focus today is on requirements that enable the safety function to react in a way that's tailored to the machine's dynamic processes. Reactions are no longer triggered only by simple logic connections, but by complex states or results of intricate calculations to which the safety function must react appropriately.

How does this affect developments in safe control technology? Dynamic safety needs the control function to dovetail closely with safety. That's why it's necessary to think more in terms of systems. If subfunctions are to fit seamlessly together, functions cannot simply be superimposed, they must be an integral part of the overall system. Developments in the control technology sector have already seen functions executed across device boundaries; similar developments will also become established in safe automation. Ultimately, the challenge lies in integrating the functions into the overall system. With highly complex dynamic tasks, insular solutions will generate no added value.

► 5.5 Safe control technology in transition

5.5.4 About Industrie 4.0

Industrie 4.0 is more than a vision of the future. Intelligent networking is a huge opportunity for industry. Flexible production can help to optimise the use of industrial plants. Customised products can be made on mass production terms, increasing the productivity of the plant. Nevertheless, many companies are still hesitant to embrace Industrie 4.0 for their own production operations. According to the McKinsey Institute study “Industry 4.0 – How to navigate digitization of the manufacturing sector”¹⁾, only six out of ten companies in Germany feel they are ready for Industrie 4.0, even though 91 percent perceive the digitisation of industrial production as an opportunity. We would like to change all that, and offer solutions and products for Industrie 4.0 to companies worldwide. Because the topic of Industrie 4.0 is increasingly coming sharply into focus in the international arena, too: the continuing process of globalisation in particular renders it necessary to prepare the way for integration through the digitisation of production processes along the entire value chain.

¹⁾ https://www.mckinsey.de/sites/mck_files/files/mck_industry_40_report.pdf



Plants can be broken down into manageable, independently functioning units.

Modular machine and decentralisation

For several years now, modular mechanical and plant engineering has been seen as the key to greater flexibility in production. A complete plant comprises multiple autonomous machine modules. A module maps one or more standardised production steps and can be combined with other modules to form a complete process. This involves connecting all modules to a backbone that supplies each of them with energy (400 VAC three-phase current, compressed air, ...) as well as with process and control data. Each product/workpiece also has access to all relevant information on the respective production process. Should the production process change or productivity increase, one or more modules may be exchanged or identical modules can be added.

Modularisation and decentralisation are consequently two of the key success factors en route to the future of automation. A prerequisite for this is automation systems that are able to control the distributed intelligence in the machine modules in a user-friendly way. All plant and machinery can then be broken down into manageable, independently functioning units.

The modular structure of plants and machinery follows the mechatronic approach. The philosophy here is to universally merge all the disciplines involved in a machine's development process: mechanics, electrics and automation technology. The interaction between diverse, individual, automation technology components and associated software tools to form an automation solution is universally defined. This universality extends across the four levels of the automation pyramid (management level, operational level, control level and field level). The mechatronic approach requires even control functionalities to be able to “migrate” into individual mechatronic modules.

► 5.5 Safe control technology in transition

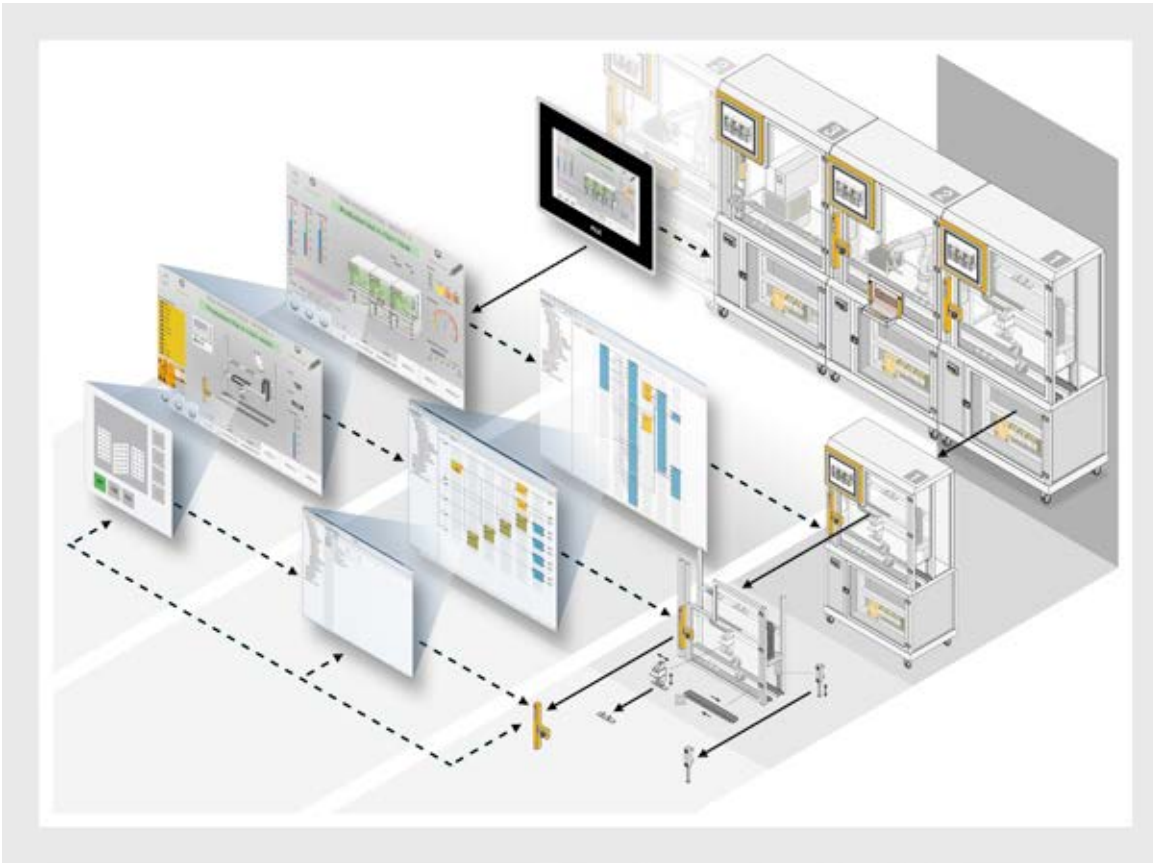

Plants can be broken down into manageable, independently functioning units.

This is where systems so far meet their limits. Although function modules can be created, when these are to be executed by powerful, central controllers, the commissioning of individual modules rapidly becomes a laborious process because of its complexity. Changes to the configuration and the programming of the individual function modules, which are subsequently needed, likewise increase the workload.

Decentralised systems make commissioning modules a straightforward affair. The configuring task, too, is very user friendly because identical control programs and subfunctions can also be used for various modules.

So the automation of the future demands solutions that are able to both distribute control intelligence and guarantee that the necessary networking of several controllers remains easy for the user to handle. Such a solution is available from Pilz with the automation system PSS 4000.

► 5.5 Safe control technology in transition

Safety and security

The ongoing development of the automation landscape with Industrie 4.0 means that companies are faced with new safety and security challenges. The world of automation is merging with the IT world. Specific perspectives on the issue of safety/security differ significantly: the internationally used terms are “Safety” for machinery safety and “Security” for IT and data security; this helps with the basic differentiation.

Safety demands that residual risks arising from a plant or machine do not exceed acceptable values. This includes hazards to the plant environment (e.g. environmental damage) as well as hazards within the plant (e.g. people inside the plant).

Security concerns the protection of a plant or machine from unauthorised access from outside as well as the protection of sensitive data from corruption, loss and unauthorised access from within. This includes explicit attacks as well as unintentional security incidents.

Comprehensive protection of production and safety-relevant control data during transfer, processing and storage must address the following areas of security:

- ▶ Physical security and availability of the IT systems
- ▶ Network security
- ▶ Software application security
- ▶ Data security
- ▶ Operational security

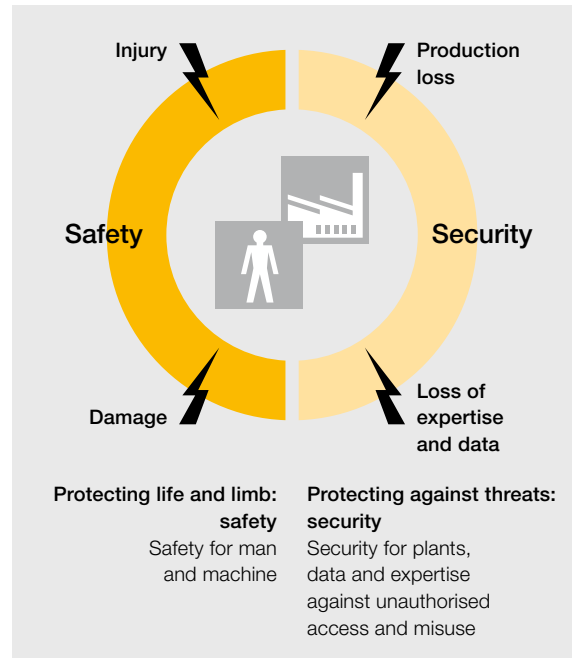

Interaction between safety and security

► 5.5 Safe control technology in transition

Action areas of Industrie 4.0

One of the principles for sustained market acceptance is to create standardised mechanisms in communication between machines and within the machine. Practical solutions that are acceptable to users will only take shape if the requirements of both worlds (automation and IT) are considered.

In summary, this means that Pilz is committed to modern control architectures in an Industrie 4.0 environment.

Our focus is on the following issues:

Modular approach:

Our modern control functions are designed for distribution and object orientation – sensors and actors have intelligence. We hereby replicate the trend towards mechatronic control objects (automation components) in our products and the corresponding engineering tools.

Safety and security:

Both have clear parallels in terms of standardisation and procedure in the engineering process. We want to utilise the experience we have gained in machinery safety and automation to drive this important work forward.

All the devices and automation components necessary for the control function receive direct Internet access to exchange process data and parameter data for diagnostics and (remote) maintenance. As a result, the demands for all the automation devices involved increase in terms of security and a standardised diagnostic interface and display.

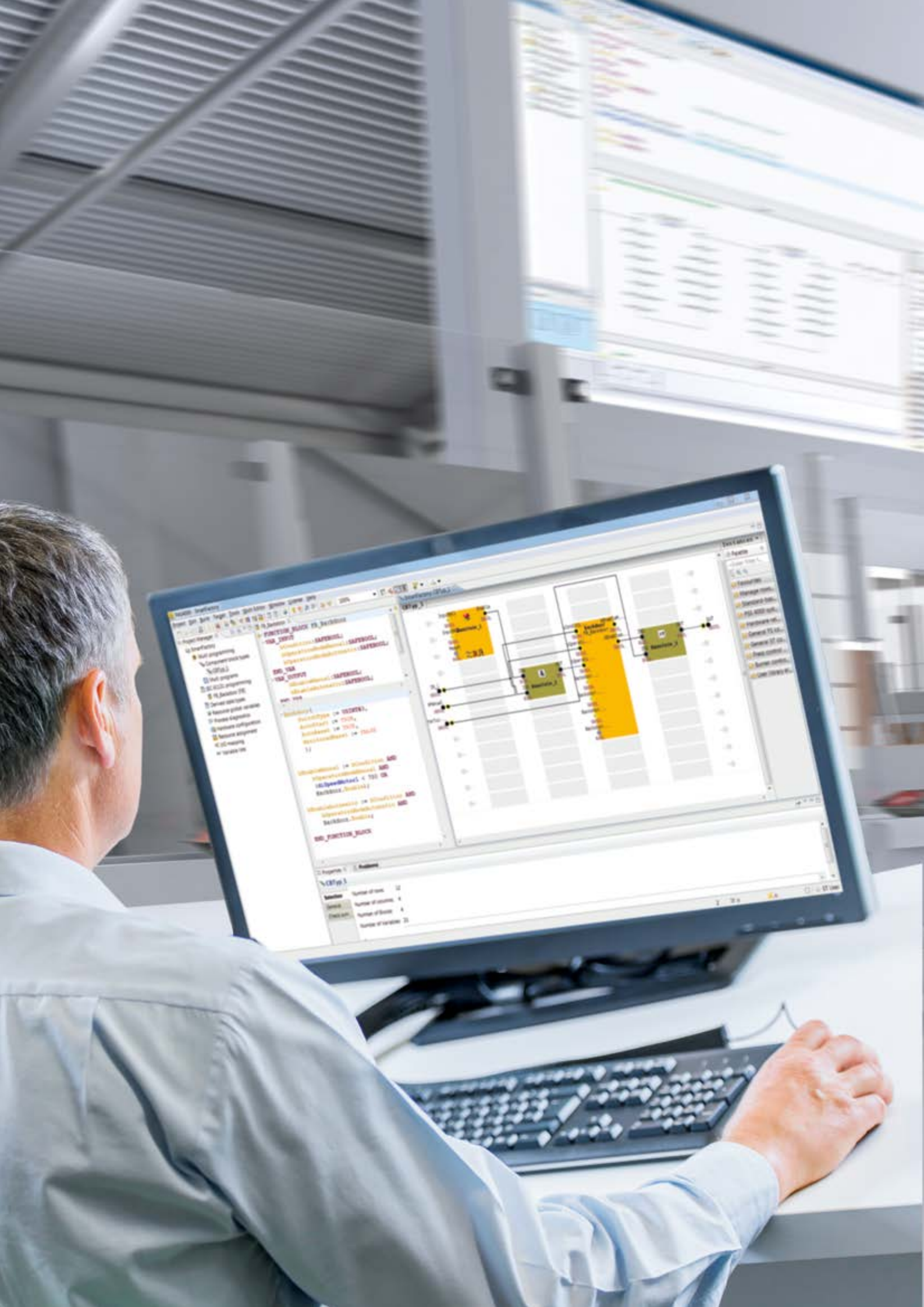



6

Safe

communication

▶ 6 Safe communication

6	Safe communication	
6.1	Basic principles of safety-related communication	6-3
6.1.1	Principle of decentralised safety technology	6-3
6.1.2	Handling communication errors	6-3
6.1.3	Principle of redundancy	6-5
6.2	Safe Ethernet communication with SafetyNET p	6-6
6.2.1	Why Ethernet in automation technology?	6-6
6.2.2	System description SafetyNET p	6-7
6.2.3	UDP/IP-based communication with RTFN	6-9
6.2.4	Hard real-time communication with RTFL	6-10
6.2.5	Application layer	6-11
6.2.6	Safe communication via SafetyNET p	6-11
6.2.7	Safe telegram structure	6-12
6.2.8	Industries, applications	6-12
6.2.9	Application example of a modular machine design	6-14

► 6.1 Basic principles of safety-related communication

Safety-related communication has already replaced parallel wiring in many of today's mechanical engineering applications. There are many reasons for this: it reduces complex wiring, simplifies diagnostics and troubleshooting and increases the availability of the whole application. The following chapter explains how safe communication operates, using SafetyNET p as an example, and also demonstrates some applications.

6.1.1 Principle of decentralised safety technology

Depending on the desired safety level, periphery devices such as E-STOP switches are generally connected to a safety controller in a dual-channel configuration. The redundancy and additional cable tests mean that faults such as short circuits or open circuits can be detected and managed. A bus cable uses single-channel, serial communication, which does not provide physical line redundancy. That's why additional measures in the protocol are needed to uncover faults such as a disconnected bus cable or communication problems.

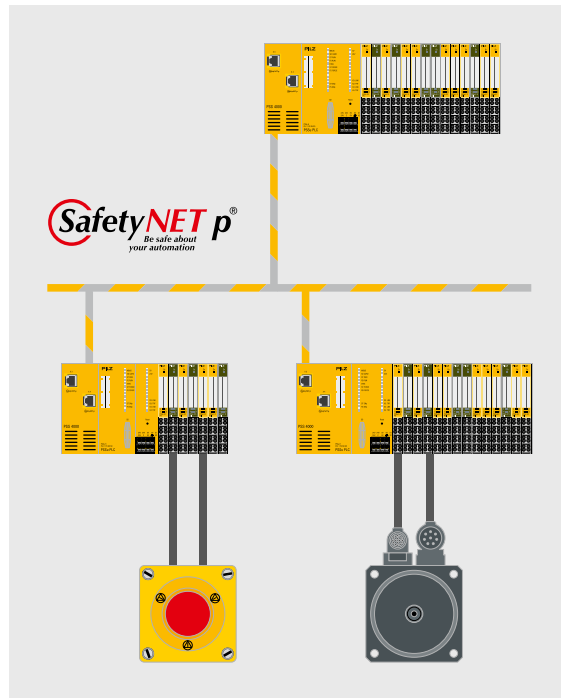

Principle of decentralised safety technology

6.1.2 Handling communication errors

The sections below describe typical errors and measures which may occur when safety-related data is communicated via an industrial communication system, and ways in which these can be handled.

6.1.2.1 Message repetition

Malfunctions within the bus subscriber or a network component can lead to telegram repetition. Each message is given a sequential number so that repeated messages are detected. The receiver is "expecting" the sequential number, so it will detect repeated telegrams and initiate appropriate measures.

▶ 6.1 Basic principles of safety-related communication

6.1.2.2 Message loss

Messages can be deleted or it can no longer be possible for telegrams to make it to the receiver due to a malfunction on a bus subscriber or a network component. The receiver uses a sequential number to detect the loss of data packets. A timeout on the receiver also monitors the latest time by which a new message must arrive. Once this timeout has elapsed, the receiver is able to bring the application to a safe condition.

6.1.2.3 Message insertion

Additional messages may creep in as the result of a malfunction on a bus subscriber or a network component. As with message repetition, the sequential number can be used to detect and manage this situation.

6.1.2.4 Incorrect message sequence

Errors on a bus subscriber or network components that store telegrams, such as Ethernet switches and routers, can corrupt the telegram sequence. However, this will be detected through the sequential numbers.

6.1.2.5 Message corruption

Malfunions on a bus subscriber or a network component or faults on the communication medium, e.g. due to EMC, can corrupt messages: a data security mechanism (check sum) applied to the safety-related telegram content will recognise this and detect the corrupted message.

6.1.2.6 Message delay

A malfunction on the bus subscriber or an incalculable data volume in the network can lead to delays: a timeout on the receiver will detect the delays and initiate appropriate measures.

6.1.2.7 Combining safety-related and non-safety-related communication functions

In mixed systems containing safety-related and non-safety-related subscribers, receivers will sometimes interpret a telegram from a standard subscriber as a safety-related telegram. Such mistakes on the part of the receiver can be avoided using measures such as unique IDs across the network and varied data security features for safety-related and non-safety-related messages.

Fault	Measures per message				
	Sequential number	Timeout	ID for transmitter and receiver	Data security	Varied data security for safety-related and non-safety-related messages
Repetition	◆				
Loss	◆	◆			
Insertion	◆		◆		
Incorrect sequence	◆				
Message corruption				◆	
Delay		◆			
Combining safety-related and non-safety-related messages			◆		◆

Errors and measures, using SafetyNET p as an example, taken from BIA GS-ET 26

▶ 6.1 Basic principles of safety-related communication

6.1.3 Principle of redundancy

In order to control potential errors when recording and processing safe signals in bus subscribers, each function is processed by at least two different components or methods, which monitor each other. When an error is detected, these components or methods are used to bring about a safe condition. On the safe bus system SafetyNET p, for example, the application software is processed by redundant microprocessors, which compare their respective results before transferring them to the redundant controller. This then generates the actual safety-related message.

► 6.2 Safe Ethernet communication with SafetyNET p[®]

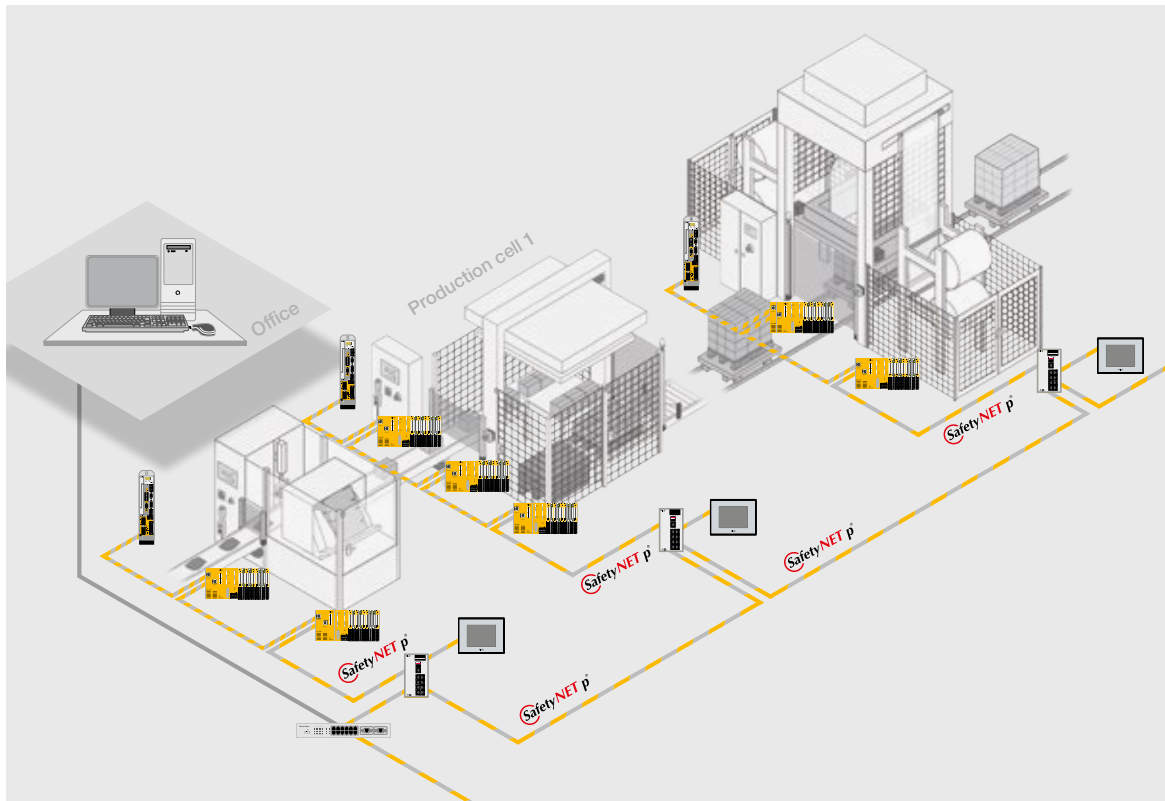

The function and application of a safe Ethernet-based bus system is explained below, using the popular safety-related bus system SafetyNET p as an example.

6.2.1 Why Ethernet in automation technology?

Automation technology is currently developing away from a centralised control system with simple binary sensors and actuators into complex, intelligent systems. The proportion of control and process capacity within the sensors and actuators is constantly growing. This trend changes the communication requirements dramatically: instead of the usual master/slave system that we see today, in future, more and more data will be exchanged directly between the subscribers. Today's individual, largely simple subscribers will increasingly assume the function of subscribers with their own computing capacity.

Modern IT technology – as seen in office communication with personal computers and network components – currently offers a wide range of system components at favourable prices. There is huge potential for innovation. That's why users are increasingly keen to modify this technology to make it usable for industrial automation technology. Ethernet plays a prominent role here; it has been the established standard in office communication for years.

The requirements of the individual elements of a production plant also continue to grow alongside this trend. This affects scan times, precision/frequency of measurements, data amounts and processor power, to name but a few. As far as the automation system is concerned, the performance of the controllers and communication systems must satisfy these growing requirements. As a modern, Ethernet-based fieldbus system, SafetyNET p meets these requirements. At the same time, SafetyNET p is as simple to install and as reliable as fieldbus systems.

▶ 6.2 Safe Ethernet communication with SafetyNET p[®]

6.2.2 System description SafetyNET p

SafetyNET p is a bus system in which all devices on a network have the same authorisations. The bus scan time of SafetyNET p can be adapted to suit the application requirements. Data is exchanged here in accordance with the publisher/subscriber principle. As a publisher, each device can provide data to the other devices (subscribers) via SafetyNET p. In turn, these subscribers can read the published data from individual subscribers or all subscribers. This way it is possible to exchange data efficiently between all the subscribers.

6.2.2.1 Security

The protocol includes a safe data channel, which is certified for data transfer in accordance with SIL 3 of IEC 61508. Both safety-related and non-safety-related data is transferred via the same Ethernet cable. Non-safety-related subscribers have direct access to safety-related data and can use it for further non-safety-related processing tasks.

Communication media

A wide range of communication media is available to SafetyNET p, enabling it to satisfy the varied application requirements. In this way, copper cables, radio links and fibre-optic cables can be used.

Fibre-optic communication

With fibre-optic (FO) communication, fibre-optic cables, transmitters and receivers are used instead of copper cables. SafetyNET p has a number of different devices for creating fibre-optic paths. This task is typically performed by Ethernet switches that offer fibre-optic converters for fibre-optic cable paths of up to 40 kilometres, depending on the application.

FO communication is found in a wide range of applications. It's important where a high EMC load would disrupt communication, as would be the case with welding robots in the automotive industry, for example. Fibre-optic paths are also frequently used for safety-related communication between the mountain and valley stations on cable cars, where it's necessary to span long distances outdoors.

Safe wireless communication

SafetyNET p data can be transmitted wirelessly using access points. From the safety controller's perspective, the access points are transparent, i.e. they are not visible as subscribers in the network. Wireless transmission does not affect the safety level of SafetyNET p.

Safe wireless communication is used when it is too complex and therefore cost inefficient to lay cables. Another application is subscribers on movable facilities. These may be rotating or linear-moved plant sections, such as those found on crane systems or automated guided vehicles. When safe wireless technology is employed, high demands are placed above all on the quality of the wireless connection, as this affects the number of telegrams that are lost as well as incorrect sequence and delays and can cause safety-related shutdowns of the application. This in turn will impact on the application's availability.

To guarantee the quality of the wireless connection, particular attention should be paid to selecting wireless and antenna technology and redundancy concepts that are appropriate for the application; these should be verified through field trials where necessary.

▶ 6.2 Safe Ethernet communication with SafetyNET p[®]

6.2.2.2 Flexible topology and scan time selection

SafetyNET p is extremely flexible, not just when it comes to selecting a suitable communication media, but also on the issue of the appropriate topology: the system supports linear, star, tree and ring topologies. The RTFL communication principle (Real Time Frame Line) is suitable for intra-cell communication, as it allows the fastest scan times. Jobs and events can be recorded and executed with high precision across the entire network. Absolutely essential for real-time applications: a jitter of around 100 ns must be achievable in real-time control loops. As a result, it's even possible to use SafetyNET p in a converter control loop between a rotary encoder and a speed regulator. Other highly dynamic applications are also possible, of course. RTFN mode (Real Time Frame Network) is usually used at higher levels, as it offers maximum coexistence capability with existing services.

6.2.2.3 Application layer

The interface with the application is based on the widely-used CANopen technology.

6.2.2.4 Standard Ethernet technology

SafetyNET p uses the widely-used UDP/IP communication for cell-to-cell communication or communication in general networks. Conventional commercially available network components are used for setting up the network infrastructure. This includes connectors, cables, switches, routers and gateways, in particular.

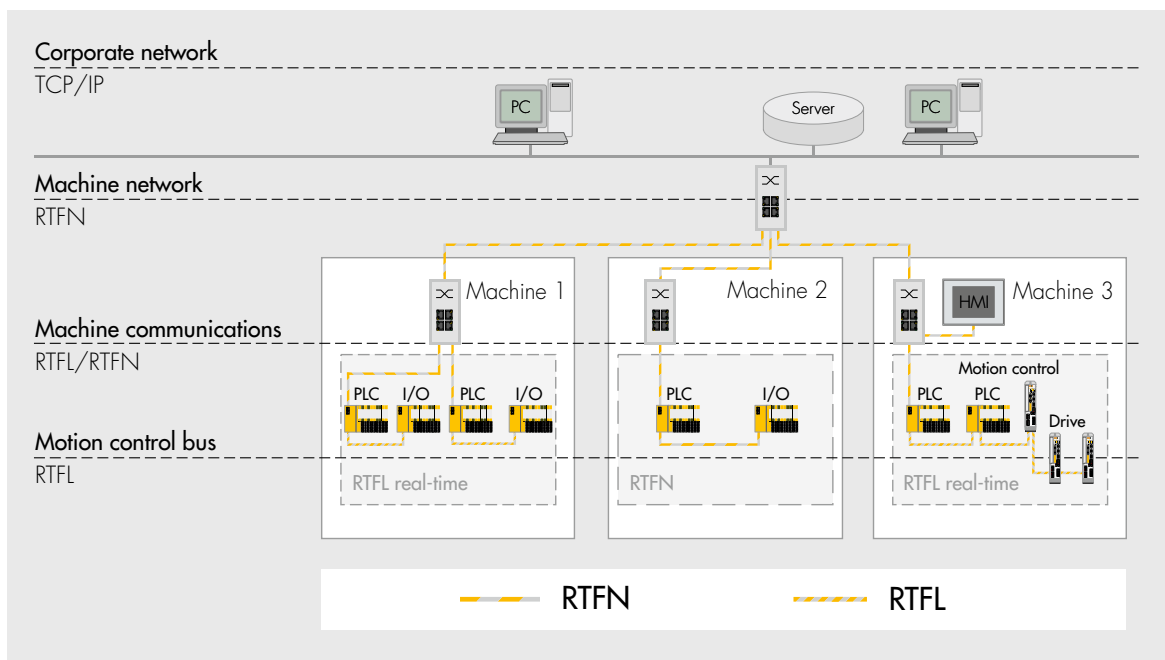

SafetyNET p in the communications hierarchy

▶ 6.2 Safe Ethernet communication with SafetyNET p[®]

6.2.3 UDP/IP-based communication with RTFN

The RTFN transport layer of SafetyNET p can be used at process control and manufacturing cell level, where standard Ethernet protocols are in demand and the real-time requirements are lower. RTFN is used to network the RTFL real-time cells and to connect subscribers, such as visualisation devices or service PCs. The RTFN level typically has a tree topology as used in the office world. Ethernet switches are used to connect the network subscribers in individual point-to-point connections.

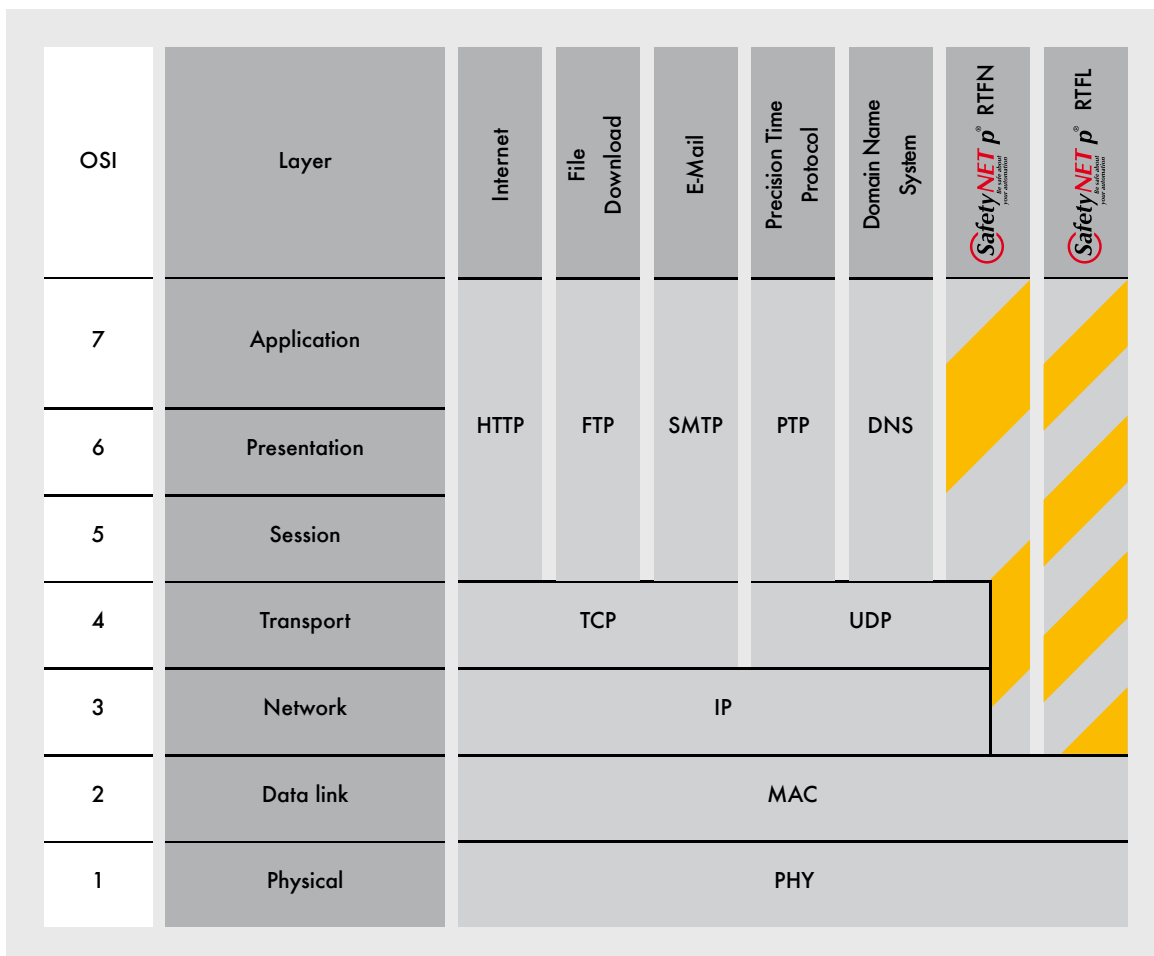

SafetyNET p in the ISO/OSI reference model

▶ 6.2 Safe Ethernet communication with SafetyNET p[®]

6.2.4 Hard real-time communication with RTFL

The RTFL transport layer of SafetyNET p is optimised for the fastest real-time applications. Typically the devices are connected in a linear structure, as with traditional fieldbus systems. Data is exchanged in accordance with the publisher/subscriber principle. As a publisher, each device can provide data to the other devices (subscribers) via SafetyNET p. In turn, these subscribers can read the published data from individual subscribers or all subscribers. This way it is possible to exchange data efficiently between all the subscribers. RTFL uses a very fast, cyclical data transmission

as the communication mechanism. Communication is initiated by a Root Device (RD). The Ethernet frame generated within the Root Device is then transferred to the other devices (OD – Ordinary Device). The ODs fill the Ethernet frame with data to be published and extract from the Ethernet frame the data to be read. Each RTFL segment requires just one Root Device. RTFL devices have two Ethernet interfaces, which enables use of the familiar daisy chain wiring often found on fieldbuses.

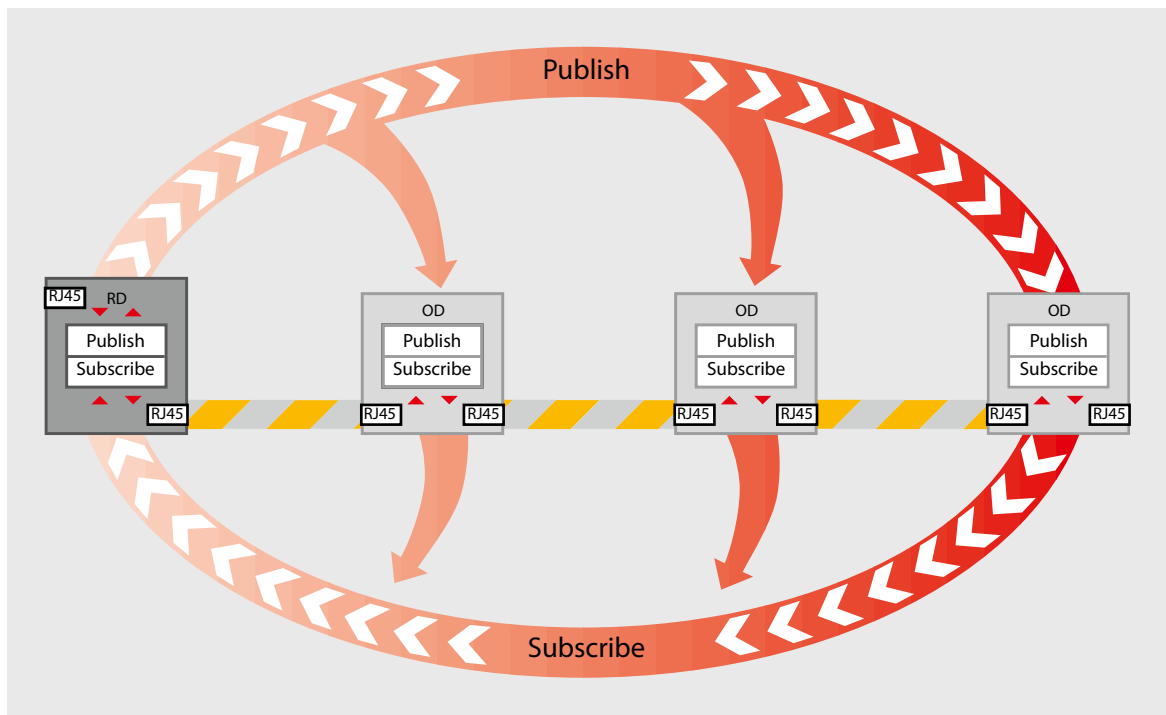

SafetyNET p RTFL communication

▶ 6.2 Safe Ethernet communication with SafetyNET p[®]

6.2.5 Application layer

The application layer of SafetyNET p adapts the mechanisms of CANopen to the conditions of SafetyNET p. CANopen is an open, manufacturer-independent fieldbus standard specified/standardised by CiA (CAN in Automation). SafetyNET p therefore has a standardised application layer for industrial applications.

The SafetyNET p application layer is largely based on the CANopen standard. The changes that have been made are mainly in the communications area and in the way safe application data is handled. The key element in CANopen is the object directory, which acts as the interface between the application and the communication subsystem. Essentially it is a grouping of objects and functions, which can then be stored and called up as application objects.

Generally, there are two possibilities for communication between devices: application data can be merged into process data objects/PDOs (mapping) and then published via the communication system. This is achieved via the cyclical data channel in SafetyNET p. The second possibility is the SDO (service data object), which is used for acyclic data and is applied when setting controller parameters, for example.

6.2.6 Safe communication via SafetyNET p

SafetyNET p can also communicate safety-related data through an integrated safe communication layer. The security mechanisms are designed to meet up to SIL 3 of IEC 61508. The safety-related data is sent encapsulated within SafetyNET p telegrams. As a result, all other network components such as switches or cable may be standard Ethernet components, which have no impact on safety. Even non-safety related network subscribers such as PCs or standard control systems, for example, have no impact on safety-related communication. As a result it is possible to mix the operation of safety and non-safety-related devices within a network.

▶ 6.2 Safe Ethernet communication with SafetyNET p[®]

6.2.7 Safe telegram structure

Cyclical data in SafetyNET p is communicated as safe PDOs (SPDOs) and has the following format:

- ▶ PID (Packet Identifier): used with the SID for unique data packet identification
- ▶ Length: complete length of packet in Bytes
- ▶ Process data: safe process data
- ▶ SID (Safe ID): 16 bit unique network-wide ID, through which both the sender and the SPDO are uniquely identifiable
- ▶ Counter No.: 8 bit cyclical counter for life sign monitoring on subscribers
- ▶ CRC: 32 bit check sum covering the whole safe data packet

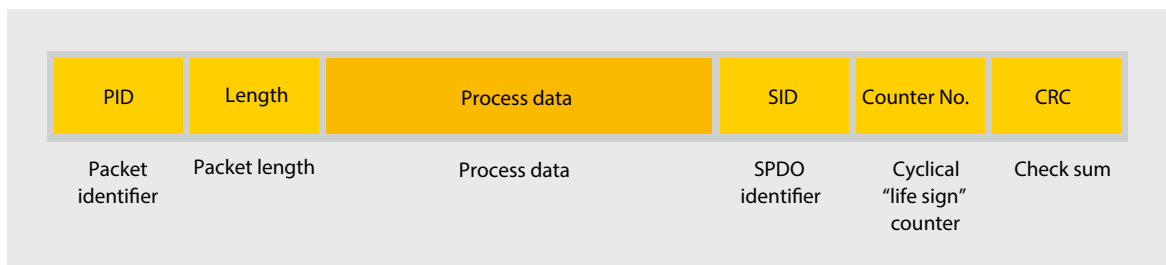

Safe PDO message

6.2.8 Industries, applications

SafetyNET p is used worldwide in a wide range of industries and applications. The list below represents only a selection.

6.2.8.1 Airports

Airports contain baggage handling and conveying technology applications in which long distances have to be covered. Safety-related equipment such as E-STOP pushbuttons and grab wires are distributed across the whole route. SafetyNET p collects the safety-related signals and makes them available to the safety controllers, which stop or shut down the drives safely if necessary.



▶ 6.2 Safe Ethernet communication with SafetyNET p[®]

6.2.8.2 Passenger transportation

SafetyNET p is also used for communication on cable cars: safety-related signals are exchanged between the mountain and valley stations and signals are collected en route. Fibre-optic cables are often used as the communication medium for covering long distances.



6.2.8.4 Automated guided vehicles (AGV)

The real-time Ethernet SafetyNET p is also used for automated guided vehicle systems. Data for automation tasks such as loading and unloading as well as for safety-related control tasks such as speed and direction of an individual transport unit is transmitted.



6.2.8.3 Crane applications

Modern control concepts based on powerful Ethernet technology. As a result, all information is available everywhere. The real-time Ethernet SafetyNET p is used in extensive crane systems, for example, for the reliable exchange and the synchronisation of control data, failsafe data and states.



► 6.2 Safe Ethernet communication with SafetyNET p[®]

6.2.9 Application example of a modular machine design

Plant and machinery are becoming increasingly modular. This means that they are being segregated into mechatronic units with separate functions. In a concept such as this, the electrical engineering follows the mechanical structure of the machine, bringing wide-ranging benefits. Once the machine modules have been developed they can be reused in various machines, which ultimately reduces the development effort. Modules can also be manufactured separately and joined together only during final assembly. What's more, modules can be developed in isolation from each other, so tasks can be run in parallel, saving time during development.

This type of engineering follows the building-block principle and enables customised solutions to be implemented at lower cost. Fieldbus systems prevent this modular approach, as they are mainly based on a centralised master/slave approach. In safety technology in particular, one central instance is usually available: the master. The publisher/subscriber communication principle applied universally on SafetyNET p does not use a central instance, thereby enabling a modular machine design.

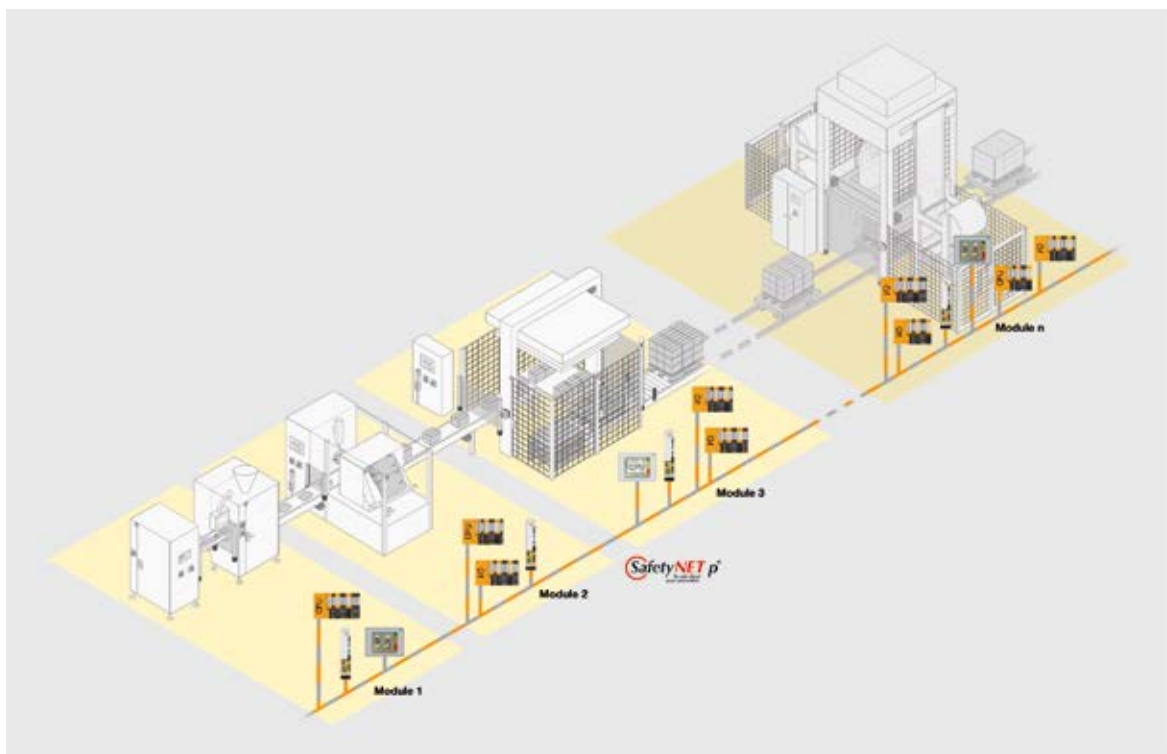

Modular machine design



7

Safe motion



▶ 7 Safe motion

7	Safe motion	
7.1	Definition of safe motion _____	7-3
7.2	Basic principle _____	7-4
7.2.1	Safe separation of the power-generating energy supply _____	7-4
7.2.2	Safe motion monitoring _____	7-6
7.2.3	Safe limit value specification _____	7-9
7.3	Standard EN 61800-5-2 _____	7-10
7.4	Safety functions _____	7-12
7.4.1	Stop functions and their standard reference _____	7-12
7.4.2	Safety functions in accordance with EN 61800-5-2 _____	7-12
7.5	System examination _____	7-22
7.5.1	Drive electronics _____	7-23
7.5.2	Motor _____	7-24
7.5.3	Safe logic _____	7-24
7.5.4	Safe braking _____	7-25
7.5.5	Motion monitoring _____	7-25
7.5.6	Motion control _____	7-26
7.5.7	Implementation examples _____	7-26
7.6	Examples of safe motion _____	7-28
7.6.1	Performance level of safety functions _____	7-28
7.6.2	Reaction times of safety functions _____	7-42

► 7.1 Definition of safe motion

Safe drive functions have recently made their mark on standards, products and applications and today can be considered as state of the art. They are part of the functional safety of plant and machinery and, as measures that boost productivity, are increasingly gaining ground in the market. The protection of machinery and equipment is also increasing in importance alongside personal protection.

When you examine the application of the failsafe principle within classic safety functions, initiation of the safety function causes the outputs to shut down, and this is called a “safe condition”. If safe drive functions are used, an application may look like this: when a safety gate is opened, the motor is braked safely with a defined ramp and then remains at standstill under active control. The motor will then move in jog mode at safely reduced speed. In other words if static detection zone monitoring has been violated, production can continue at a reduced number of cycles and with safely monitored movements.

What this simple example illustrates is the transition from static to dynamic safety. Dynamic means something different in the various disciplines. In safety technology, dynamic is understood to be the ability to adapt the safety functions to the changing detection zones. The functional safety

requirements for variable speed drives specified in EN/IEC 61800-5-2 open up new horizons on this issue.

The main requirements of safe drive systems in terms of dynamic safety are:

- ▶ Safe monitoring of kinematic variables such as acceleration, speed, distance, for example
- ▶ Short reaction times to reduce stopping distances
- ▶ Variable limit values, which can be adapted to suit the runtime

Drive-integrated safety technology, fast, safe drive buses, high-performance programmable safety systems and safe camera systems are all products suitable for high-end safety solutions. The term “safe motion” is interpreted differently, depending on your perspective. Drive manufacturers generally understand safe motion to be drive-integrated safety, whereas controller manufacturers associate it with external solutions. Looking at the issue independently we can establish that the term “safe motion” only refers in the first instance to the implementation of a safe movement.

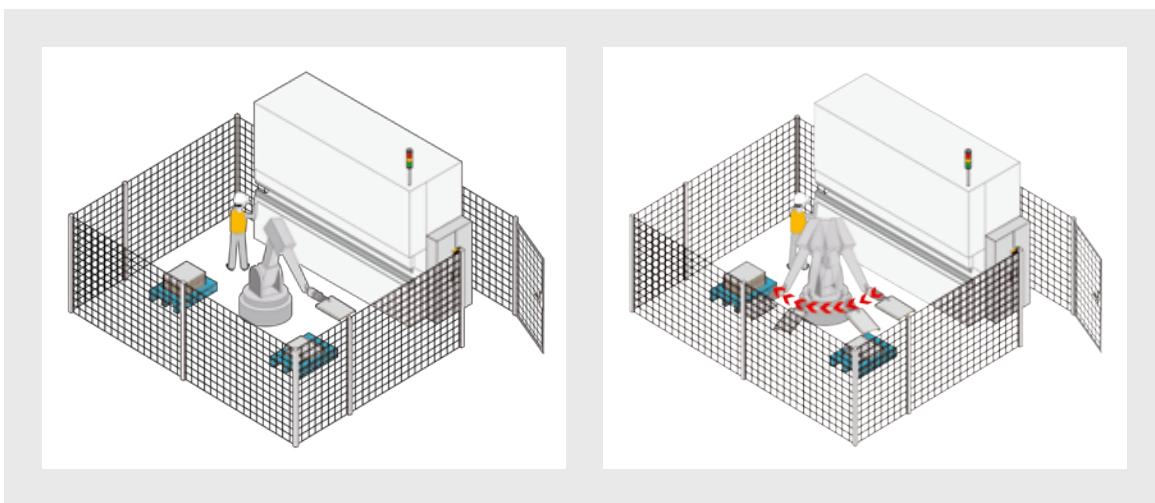

Comparison of static and dynamic safety

▶ 7.2 Basic principle

The objective of safety technology has always been to prevent potentially hazardous movements. Nothing, then, is more obvious than to dovetail safety technology with motion generation. For technical and economic reasons, the drive electronics – servo amplifiers and frequency converters – have remained non-safety-related components within automation. So safety is guaranteed through additional safe components, which bring the motor to a zero-power, safe condition in the event of a fault, or safely monitor the movement of the connected motor. The current market trend is to integrate these safe components into the drive.

In accordance with the current state of the art, a safe motion controller is a combination of safe motion monitoring, safe isolation of the motor from the power-generating energy supply and non-safety-related motion generation.

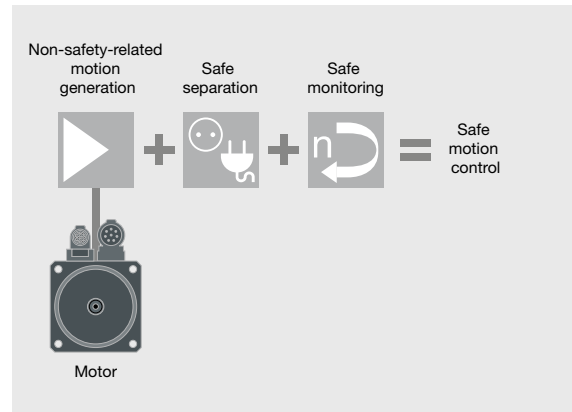

Components used in safe motion control

The following details refer to three-phase drive systems, as currently used in an industrial environment. Applying these to other actuator systems (e.g. DC drives, servo valves, ...) is only possible under certain conditions and needs to be examined separately.

7.2.1 Safe separation of the power-generating energy supply

Before explaining the different shutdown paths on a converter it is necessary to understand the fundamental mode of operation.

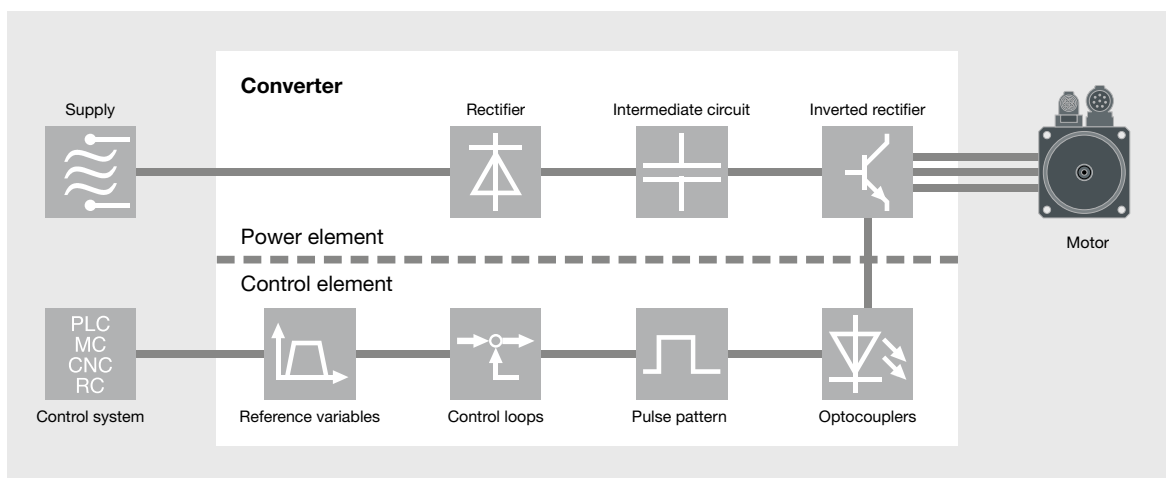

Converter's fundamental mode of operation

► 7.2 Basic principle

Internally a converter is divided into a control element and a power element. Both elements are galvanically isolated from each other via opto-couplers. The power element is where the power fed in from the mains is prepared. A terminal voltage with variable amplitude and frequency is generated from the mains voltage and its constant amplitude and frequency. First of all, the sinusoidal mains voltage in the rectifier is converted into a pulsating DC voltage. This is smoothed through a down-stream capacitor – also known as an intermediate

circuit. The intermediate circuit is also used to absorb the braking energy. The inverted rectifier then generates an output voltage with sinusoidal fundamental wave through cyclical switching of positive and negative intermediate circuit voltages. The converter's control element uses reference variables to generate pulse patterns, which are used to drive the power semiconductors on the inverted rectifier module. There are several possible ways of isolating the motor from the power-generating energy supply:

Shutdown path	Principle or device	Technology
1 Mains isolation	Mains contactor	Isolation of supply voltage to the converter
2 Motor isolation	Motor contactor	Isolation of the motor terminal voltage
3 Drive-integrated isolation	Safe pulse disabler	Isolation of the control signals to the power semiconductors
4 Isolation of reference variable	Setpoint setting to zero	Controller does not generate control variables (processor-based)
5 Isolation of control variable	Controller enable	No control signals are generated for the power semiconductors.

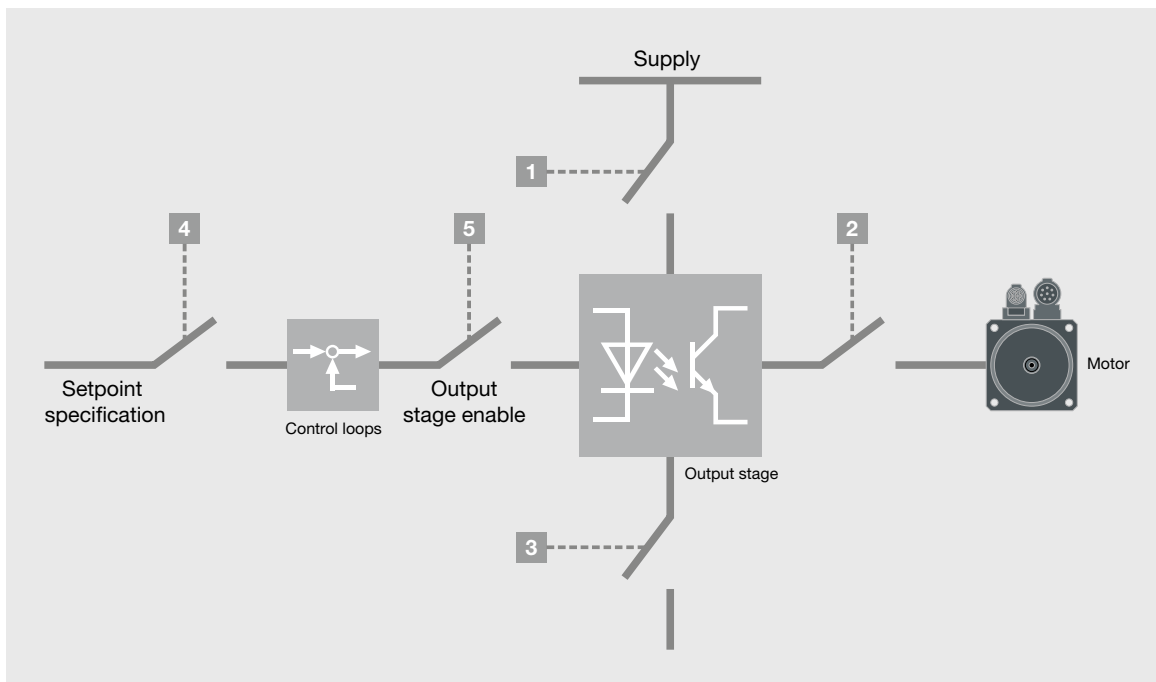

Converter's shutdown paths

► 7.2 Basic principle

If the power-generating energy supply is isolated via the mains or motor, the mains or motor contactor must have positive-guided contacts. If the N/C contact is linked to the start signal on the converter, a fault on the contactor contact will be detected. The highest category can be achieved if two contactors are connected in series and each is fed back to the N/C contacts. The disadvantage of mains isolation is that the intermediate circuit capacitor on the power element is discharged each time power is isolated and must be recharged when restarting. This has a negative impact on restart time and machine availability and also reduces the service life of the intermediate circuit capacitors, because the charge/discharge processes accelerate ageing of the capacitors.

If the motor was isolated, the intermediate circuit would stay charged, but disconnecting the motor cable for wiring the contactor is a very complex process, so it is only rarely used in practice. Also, the use of motor contactors is not permitted on all converters. Potential overvoltages when isolating the contacts may damage the inverted rectifier. If there is a frequent demand to separate the power-generating energy supply as a safety function, there will also be increased wear on the positive-guided contacts on the mains or motor contactor. Isolation of the reference variable (setpoint specification) or control variable (output stage enable) can be combined with the above shutdown paths. As the setpoint specification and output stage enable are frequently processor-based functions, they may not be used in combination, so that common cause failures are excluded.

The drive-integrated solution is based on the principle that the pulse patterns generated by the processor are safely isolated from the power semiconductors. On the drive systems examined in this case, motor movement results from an in-phase supply to the winding strands. This must occur in such a way that the overlap of the three resulting magnetic fields produces a rotating field. The interaction with the moving motor components creates a force action, which drives the motor. Without the pulse patterns, no rotating field is created and so there is no movement on the motor. The optocouplers, which are used for galvanic isolation between the control and power element within a converter, are ideally suited as a shutdown path. For example, if the anode voltage of the optocoupler is interrupted and combined with the isolation of the control variable (control enable) mentioned previously, motor movement is prevented through two channels. In practice, testing of the shutdown paths is undesirable because stopping the motor interrupts production.

7.2.2 Safe motion monitoring

Motion is described through the kinematic variables acceleration, speed and distance. As far as potential hazards are concerned, torques and forces also play a key role. The above variables are covered by the safety functions listed in the standard EN/IEC 61800-5-2. The implementation of safety-related monitoring is heavily dependent on the sensor technology used within the system. The sensor technology used within the drive technology is generally not safety-related and must be monitored for faults. For example, a critical status would occur if the encoder was unable to supply a signal due to a defect, while power is applied to the motor and it is accelerating.





► 7.2 Basic principle

Moved axes in safety-related applications need redundant positional information in order to carry out relevant safety functions. There are various ways to obtain independent position values: one possibility is to detect the defect through a second encoder. In this case, a safe component would have to monitor both encoders and guarantee that the plant is switched to a safe condition if an error occurs. Sometimes the advantage of this solution is that the two encoder systems detect the movement at different points on the machine and so can detect defective mechanical transmission elements.

Encoders generally have several signal tracks, enabling them to detect direction or defined positions within a revolution, for example. These signals can also be consulted for feasibility tests, so that a second encoder system is not required. However, this is not a universal dual-channel structure as the movement is recorded from a shaft or lens. Dual encoder systems are also now available on the market. Such systems are suitable for functions such as safe absolute position. With a strict, diverse, dual-channel design it is even possible to achieve SIL 3 in accordance with EN/IEC 61508. In addition to an optical system, a magnetic sensing system may also be used, for example.

Multi-turn encoders offer a more economical solution; they set their separate multi-turn and single-turn tracks in proportion and can therefore detect faults. In this case, safety-related pre-processing takes place within the encoder system itself. Another option is to use motor signals: by recording voltages and/or currents, calculations can be used to indicate the mechanical movement of the motor. A comparison with the encoder signals will uncover any dangerous failures. The product standard for electrical drive systems with integrated safety functions EN 61800-5-2 contains a list of fault assumptions for various motion and position sensors (Annex D, Table D.16).

The combination of encoder system and safe evaluation must guarantee that dangerous failures are prevented by means of fault exclusions or fault-detecting measures.

Encoder signal	Description
	Initiator signal: generated by scanning a cam or cogwheel, analogue signal with 24V level
	Two analogue signals, 90° out of phase, either square or sinusoidal (level: TTL, 24 V, 1 Vss)
10101	Digital interface, which transmits coded positional information (SSI, fieldbus)
10101 sin  cos 	Digital motor feedback interface with additional analogue signals (EnDat, Hiperface, BiSS)
10101 CRC	Safe digital interface, which transmits coded positional information (SafetyNET p, CANopen Safe, PROFIBUS and PROFINET with PROFIsafe, ...)

Standard encoder interfaces

► 7.2 Basic principle

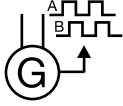
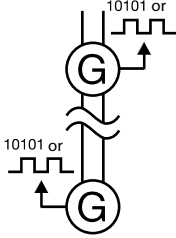
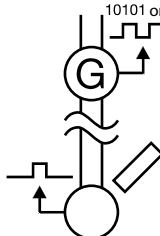
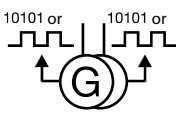
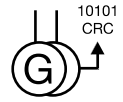
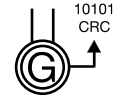
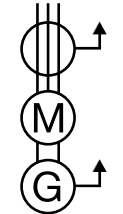
Encoder system	Description	Safety integrity
Standard encoder 	Evaluation of two signal tracks on a common lens	Low
Two encoders 	Two totally separate channels, expensive	Very high
One encoder and initiator 	Two totally separate channels, expensive, imprecise	Average
Safe encoder 	Two independent encoder systems in one housing, without safe pre-processing	High
Safe encoder 	Two independent encoder systems in one housing, with safe pre-processing	High
Safe encoder 	Dual-channel diverse structure in one encoder housing, with safe pre-processing	High
Standard encoder and motor signals 	Two totally separate and diverse channels	Very high

Encoder systems for safety-related applications

► 7.2 Basic principle

It must be examined on a case-by-case basis whether an encoder system in combination with a drive-integrated solution or an external monitoring device achieves the safety integrity required by the application. Safe encoder systems often make demands of the evaluation device (e.g. diagnostic tests) or indicate faults that are not controlled by the encoder itself. These must then be checked against the fault-detecting measures of the special evaluation device. There are often also gradations in the maximum achievable safety integrity.

7.2.3 Safe limit value specification

Safe motion monitoring requires not just safe motion detection but also the opportunity to specify limit values safely. The way in which this is achieved depends on the level of dynamics and the flexibility within the machine.

Limit values	Description	Dynamics
Constant	Fixed during commissioning and cannot be amended during operation.	-
Selectable	Possible to select/change the appropriate value from a fixed set of limit values during operation.	O
Dynamic	Limit values are calculated and adjusted during operation.	+

Dynamic and static limit values

Relay-like systems often use constant limit values. For example, a fixed limit value can be defined by setting jumpers or via other setting options on the device. On safe controllers, multiple limit values can be defined via configuration or programming user interfaces. Selection can be made during operation via a safe I/O interconnection, through evaluation of sensor signals or through specification via a safe fieldbus, for example. Dynamic limit values can only be used in conjunction with a powerful, safe controller or a safe bus system with real-time capabilities. When combined with optical monitoring of the protected field in robot applications, for example, safe speed can be reduced based on the distance of the operator from the danger zone: the closer the operator comes to the danger zone, the slower the motors move.

► 7.3 Standard EN 61800-5-2

Adjustable speed electrical power drive systems – Part 5-2: Safety requirements – Functional: Part 5-2 of the standard series EN 61800 is a product standard for electrical drive systems with integrated safety functions. It defines the functional safety requirements for developing safe drives in accordance with the standard EN 61508. It applies to adjustable speed electrical power drive systems, as well as servo and frequency converters in general, which

are dealt with in other parts of the standard series EN 61800.

EN 61800 Part 2: General requirements - Rating specifications for low voltage adjustable frequency a.c. power drive systems, lists a series of new terms, which are explained in greater detail below:

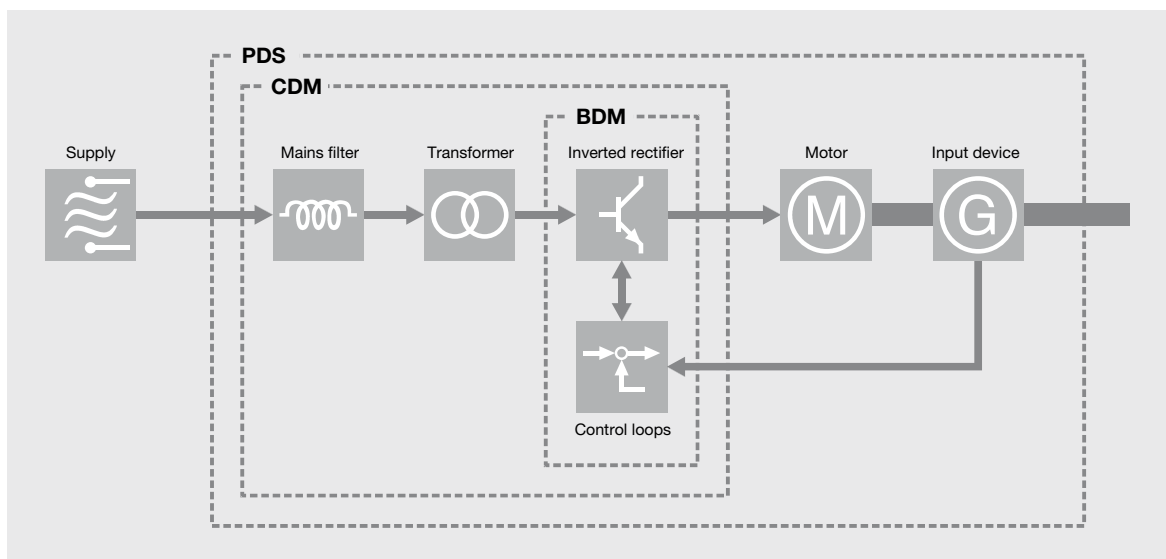

Definition of a power drive system (PDS)

Power drive system (PDS)

System comprising power equipment (power converter module, AC motor, feed module ...) and control equipment. The hardware configuration consists of a complete drive module (CDM) plus a motor or motors with sensors, which are mechanically connected to the motor shaft (the driven equipment is not included).

PDS/Safety-related (SR)

AC power drive system for safety-related applications

Complete drive module (CDM)

Drive system without motor and without a sensor connected mechanically to the motor shaft; it comprises, but is not limited to, the BDM and expansions such as the feed module and auxiliary equipment.

Basic drive module (BDM)

Drive module consisting of a power converter module, control equipment for speed, torque, current, frequency or voltage and a control system for the power semiconductor components, etc.

▶ 7.3 Standard EN 61800-5-2

Manufacturers and suppliers of safe drives can demonstrate the safety integrity of their products by implementing the normative provisions of this part of EN 61800. This enables a safe drive to be installed into a safety-related control system by applying the principles of EN/IEC 61508, its sector standards (e.g. IEC 61511, IEC 61513, IEC 62061) or EN ISO 13849.

This part of EN 61800 does NOT define any requirements for:

- ▶ *The hazard and risk analysis for a specific application*
- ▶ *The specification of safety functions for this application*
- ▶ *The assignment of SILs to these safety functions*
- ▶ *The drive system, with the exception of the interfaces*
- ▶ *Secondary hazards (e.g. through failures within a production process)*
- ▶ *Electrical, thermal and energy safety considerations covered in EN 61800-5-1*
- ▶ *The manufacturing process of the PDS/Safety-related (SR)*
- ▶ *The validity of signals and commands for the PDS/Safety-related (SR)*

▶ 7.4 Safety functions

7.4.1 Stop functions and their standard reference

Stop functions are found on almost all machines. EN 60204-1 defines three categories of stop function for the various functional requirements:

- ▶ Stop category 0
- ▶ Stop category 1
- ▶ Stop category 2

A category 0 stop leads to an immediate interruption of the power-generating energy supply to the machine actuators. Activation of the mains isolating device automatically triggers a category 0 stop, as power is no longer available to generate the movement. With a category 1 stop, the power-generating energy supply to the actuators is maintained to enable a controlled stop. Stop category 2 is used if power is required even in a stop condition, as power is maintained after the controlled stop. These stop categories should not be confused with the categories in accordance with EN ISO 13849-1, which categorise structures with a specific behaviour in the event of a fault. For speed-controlled drive systems, EN 61800-5-2 assigns stop functions to the stop categories listed in EN 60204-1.

EN 60204-1	EN 61800-5-2
Stop category 0	Safe torque off (STO)
Stop category 1	Safe stop 1 (SS1)
Stop category 2	Safe stop 2 (SS2)

7.4.2 Safety functions in accordance with EN 61800-5-2

Today's state-of-the-art technology enables stop functions to have a drive-integrated solution. This solution reduces the space requirement in the control cabinet and also the amount of wiring necessary, as additional external components required in the past, such as contactors, are now superfluous. Even additional components to monitor standstill or speed are now surplus to requirements. Servo amplifiers with integrated safety functions in accordance with EN 61800-5-2 are now available, providing much simpler solutions, even for complex safety requirements. The standard EN 61800-5-2 divides safety functions into stop functions and miscellaneous safety functions. The description is only rudimentary and allows a great deal of freedom in how it is implemented and interpreted. This is particularly evident with the stop functions, which are among the most complex of safety functions. The implementation method can vary greatly, but so too can the external behaviour of the safety functions.

When the safety functions are operated in practice, subsequent effects can often be attributed to the poor quality of the sensor signals or to the actual behaviour of an electrical drive in general. Poorly tuned control loops and EMC are frequently the cause of restricted availability of safe drive axes. One example of this is the definition of standstill: on a closed loop system, zero speed is more of a theoretical value. Depending on the quality of the control loops, some motor jitter may be observed around the zero position; if the limit value was set to zero, this would immediately trigger a reaction on account of a limit value violation. The safety function would shut the drive down safely – at the expense of system availability. In this case, it helps to define a standstill threshold > 0 , where the permitted speed is still non-hazardous. An alternative is to define a position window, from which the motor may not deviate. In this case, even the slightest movements would not lead to a limit value violation.

▶ 7.4 Safety functions

To guarantee the security of the manufacturing and production process as well as the safety of personnel, safety functions may also be permanently active, without the requirement of the plant remaining in a special operating mode. Several components and their respective interfaces must be considered in order to implement the safety functions, as well as the

whole safety chain when calculating the required safety integrity.

It is not mandatory for the safety functions listed in EN 61800-5-2 to be implemented using drive-integrated safety. An external solution may also be used.

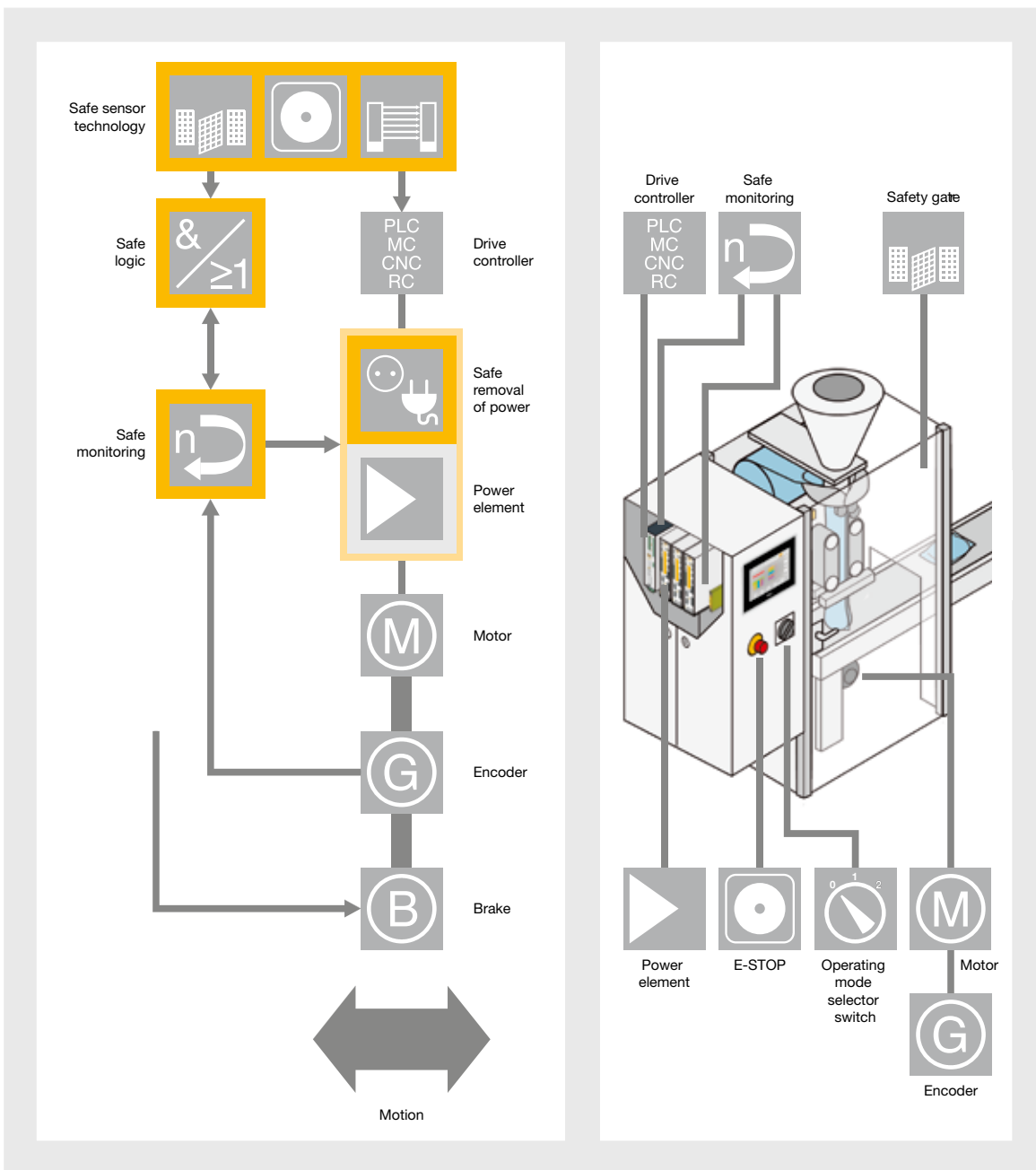

Safety chain

► 7.4 Safety functions

7.4.2.1 Reaction functions

If faults or limit value violations are identified by the safety functions, defined reaction functions must be initiated. EN 61800-5-2 frequently talks of the limiting of speeds or positions. This is achieved by initiating a stop of the motor as a reaction function in the event of a violation of limit values. However there are also applications where direct shutdown after a limit value violation is undesirable. For multi-axis applications, for example, it may make sense for a limit value violation merely to be reported by the individual axis and for a higher-level safety controller to take care of coordinated braking of the entire system of axes. External monitoring relays can equally merely report limit value violations. In combination with a safe shutdown path, the requirements of the normative safety functions can then be satisfied.

7.4.2.2 Safe stop functions

When considering safety on axes, the main factors are to prevent the axes from starting up unexpectedly and to shut down moving axes safely in the case of danger. The corresponding functions are summarised here under the heading of “Safe stop functions”.



Safe stop functions

Safe torque off (STO)

The power-generating energy supply to the motor is safely removed, so that no further movement is possible. It is not necessary to monitor standstill. If an external force effect is to be anticipated, additional measures should be provided to safely prevent any potential movement (e.g. mechanical brakes). Classic examples are vertical axes or applications with high inertia. This safety function corresponds to a category 0 stop (uncontrolled stop) in accordance with IEC 60204-1. If the function is triggered during operation, the motor will run down in an uncontrolled manner, which is not desirable in practice. That is why this function is generally used as a safe restart interlock or in conjunction with the safety function SS1.

Modern servo amplifiers include an integrated safe shutdown path, so safe devices are now available that prevent unexpected start-up and shut down safely in the case of danger.

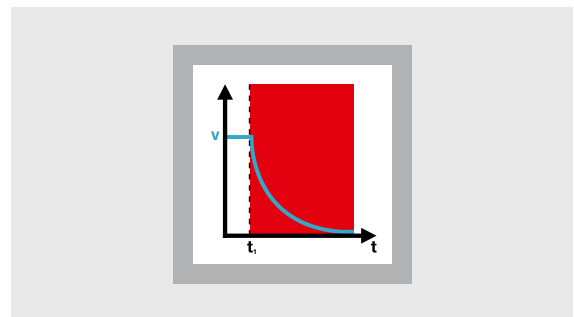

Safe torque off

▶ 7.4 Safety functions

Safe stop 1 (SS1)

With safe stop 1 (SS1), defined motor braking is part of the safety function. When the motor is at standstill, the STO function is triggered. There are various options for implementing these requirements; the key factor is the dovetailing of safety

technology and drive technology. This safety function corresponds to a category 1 stop (controlled stop) in accordance with IEC 60204-1.

Implementation	Description
Monitored time delay	Triggering of the safety function starts an application-specific, safe time delay, after which the power is safely removed from the motor. Motor braking is a function of the non-safety-related drive technology. Should the motor accelerate during this time delay, it will not be detected.
Automatic standstill detection with monitored time delay	The monitored time delay is combined with standstill detection. If the motor reaches standstill before the time delay has elapsed, the STO function will be triggered. Here too, motor acceleration during the time delay will not be detected.
Monitoring of the braking ramp	A monitored braking ramp provides the highest quality in terms of functional safety. During the braking process, values are continuously compared with a limit value or a permitted drag error. If the limit value is violated, the STO function is triggered.

In many applications, drives cannot simply be shut down as they would then run down slowly, which could cause a hazard. Also, an uncontrolled run down of this type often takes considerably longer than controlled axis braking. The safe stop 1 function (SS1) monitors controlled braking of the axis directly within the servo amplifier. Once the set braking ramp has run its course, the drive is shut down safely. The reaction times are reduced compared with external monitoring solutions; as a result, in many cases the safety distances to the danger points can also be reduced. This provides a number of benefits, such as improved ergonomics for the plant operator, space savings due to the reduced distance between the guards and the danger points and, last but not least, cost savings.

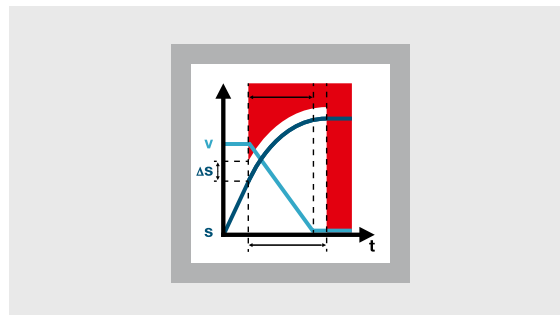

Safe stop 1

▶ 7.4 Safety functions

Safe stop 2 (SS2)

With safe stop 2 (SS2), defined motor braking is again part of the safety function. When the motor is at standstill, a safe operating stop (SOS) is triggered. Unlike safe stop 1 (SS1), the motor at standstill is in closed loop operation. This means that the standstill position is held precisely, due to

the active control loop. Again, there are several options for implementing these requirements. This safety function corresponds to a category 2 stop (controlled stop) in accordance with IEC 60204-1.

Implementation	Description
Monitored time delay	Triggering the safety function starts an application-specific, safe time delay, after which a safe operating stop is triggered. Motor braking is a function of the non-safety-related drive technology. Should the motor accelerate during this time delay, it will not be detected.
Automatic standstill detection with monitored time delay	The monitored time delay is combined with standstill detection. If the motor reaches standstill before the time delay has elapsed, the safe operating stop will be triggered. Here too, motor acceleration during the time delay will not be detected.
Monitoring of the braking ramp	A monitored braking ramp provides the highest quality in terms of functional safety. During the braking process, values are continuously compared with a limit value or a permitted drag error. If the limit value is violated, the STO function is triggered, otherwise a safe operating stop will follow.

So what are the benefits of the safe stop 2 (SS2) function? If the axes no longer need to be shut down at standstill, they will actively hold their current position, so the synchronisation between axes and process is no longer lost. As a result, the axes can be restarted immediately at any time, which clearly increases plant availability. Here too, the drive-integrated function leads to shorter reaction times, thereby minimising the risks. The monitoring functions' response times have a direct influence on the potential channels available until a safety shutdown occurs. As the reaction times are used in the calculation of the safety distances, the benefits listed for the safe stop 1 function will also apply here.

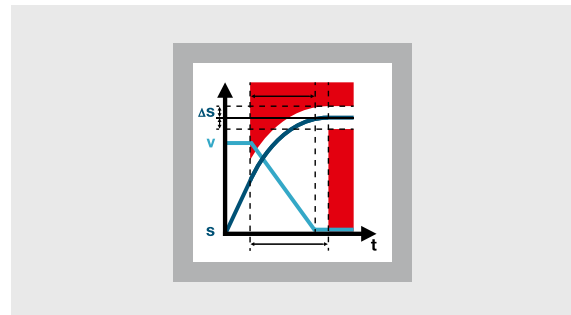

Safe stop 2

► 7.4 Safety functions

7.4.2.3 Safe motion functions

Modern drive solutions not only examine how axes are switched on and off, but also look at the potential risks that may arise during operation of the axes. The functions employed to avoid/reduce these risks are summarised here under the heading of “Safe motion functions”.



Safe motion functions

Safe operating stop (SOS)

The safe operating stop (SOS) has already been described with the safe stop 2 (SS2) safety function. It monitors the standstill position while the motor is in a controlled loop status. Once the safety function has been lifted, the production or machining process can be continued with no loss of precision. This function is generally used in combination with a safe stop 2 (SS2) function, as standstill monitoring usually involves a braking process. As described above, the limit value can be specified as both a speed threshold and a position window.

Application of the safe operating stop (SOS) function is generally intended for the standstill phases of a process. A typical situation would be access to a danger point during process intervention. An operator stops production using a command such as “Stop at end of cycle”, for example. Once the plant has stopped, the safe operating stop (SOS) function is activated, after which the guard locking device on the access gate is unlocked. The plant can now be accessed without risk.

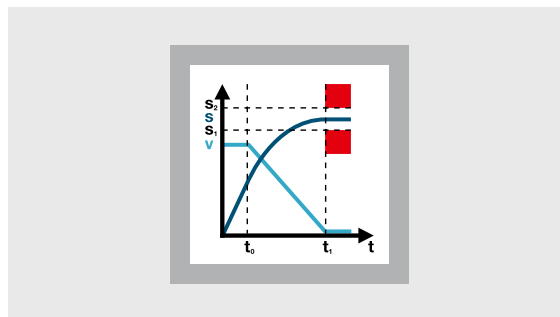

Safe operating stop

Safely limited acceleration (SLA) and Safe acceleration range (SAR)

Safety functions relating to acceleration monitoring are not widely used in state-of-the-art technology. In servo drive technology, Ferraris sensors are used to detect acceleration only in special applications of machine tools or printing machinery. Standard drives cannot process these signals in their control loops; monitoring of these acceleration signals is very complex in practice. Another option is to differentiate safe speed and position changes according to time, and to compare the momentary acceleration calculated from these with limit values. Such methods are used successfully for stationary braking and acceleration ramps. In the case of less stable motion paths, even small fluctuations in speed lead to high acceleration values because of the time derivative, and therefore lead to shutdown of the drive.

► 7.4 Safety functions

Safely limited speed (SLS)

Safely limited speed (SLS) is probably the best known safety function. In practice, this safety function is often applied as safely reduced speed. As a result, a defined transition from the operating speed in automatic mode to the reduced speed in setup mode must be guaranteed. If the monitoring function detects that the limit value has been violated, the drive must be shut down safely. The manner in which the shutdown is achieved depends on the application; it is best to aim for defined braking using the SS1 function, followed by removal of the power-generating energy.

Without drive-integrated safety functions, the implementation of this function involved high material costs or functional restrictions. Where axes are moved in jog mode during setup, the potential axis speed in the event of a fault is a key aspect of any risk analysis. Operators must be protected from any hazard that would lead to an uncontrolled axis start-up in the event of a fault. When the safely limited speed (SLS) function is used for these jog functions, the solution provides the shortest possible reaction time in the event of a fault. This reduces the risks to the operator significantly, as any uncontrolled axis start-up would be detected at the onset and would result in a safe shutdown.

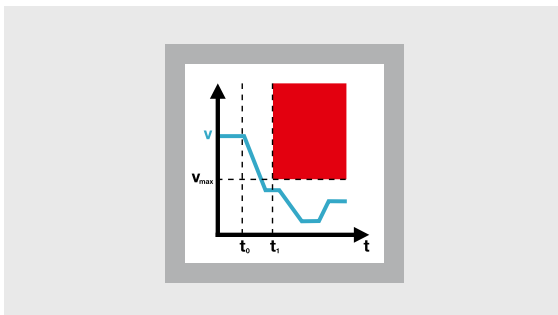

Safely limited speed

Safe speed range (SSR)

The safe speed range (SSR) can be used to monitor a safe minimum speed, for example. Again, the reaction that occurs when a value falls below the stated limit value depends heavily on the application. Drive axes may be coupled, in which case an appropriate reaction must be triggered when shutting down the drive (e.g. selective shutdown).

Safe speed range (SSR) can generally be used for permanent process monitoring. Risks cannot always be eliminated just by limiting the capacity for speeds to suddenly increase. Speeds that reduce suddenly as the result of a fault can also present a risk. If axes are operating at a defined distance, a speed that drops abruptly on just one of the two axes may create a risk of crushing. These are the cases for which the safe speed range (SSR) function have been defined and developed. This function would be used to shut down the relevant axes, thereby eliminating any hazard to the machine operator.

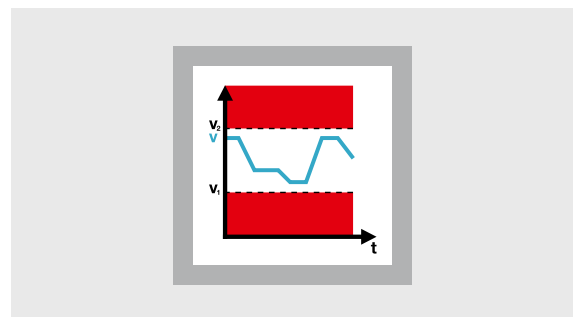

Safe speed range

► 7.4 Safety functions

Safely limited torque (SLT) and safe torque range (STR)

Like acceleration monitoring, the problem with torque or force monitoring is the lack of suitable or established sensor technology. Torque measuring systems are not widely used on standard drives, but servo drive technology provides the option for indirect measurement via the motor current. The motor current is proportional to the motor's force or torque, so the hazard resulting from a hazardous movement is limited. Non-hazardous values as regards the effect of forces can be found in the limit value list 2015, in the BIA Report.

Safely limited position (SLP)

Safe position monitoring ensures that the motor does not exceed a preset position limit value. If a limit value is violated, the motor is braked using a safe stop. The stopping performance achievable from a technical point of view must be taken into account. Below the limit value there are no restrictions in terms of acceleration or speed of the motor. Absolute position detection is required for this safety function. Absolute encoders may be used or relative measuring systems may be combined with a safe reference run.

Safely limited increment (SLI)

The motor is allowed to travel a permitted distance following a start command. A safe stop function must be triggered once the limit value is reached. If the permitted distance is exceeded, this must be detected and the drive must be safely brought to a standstill. Encoder systems with relative measurement are sufficient for this safety function.

Safe direction (SDI)

This prevents the motor from moving in an invalid direction. This safety function is frequently used in combination with safely limited speed (SLS) in setup mode. Here too, the drive-integrated solution enables the fastest possible shutdown.

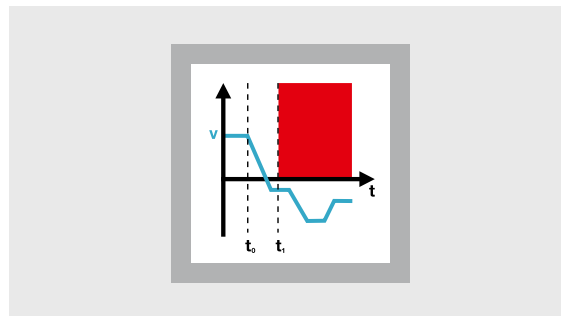

Safe direction

Safe cam (SCA)

A safe output signal indicates whether the motor is positioned inside a specified range. These ranges are absolute position windows within a motor rotation. The basic function involves safe monitoring of absolute positions, which is why appropriate sensor systems must be used.

Safe speed monitoring (SSM)

The safe speed monitoring safety function (SSM) is very closely related to safely limited speed (SLS). However, if a limit value is violated there is no functional reaction from the components that are monitored, merely a safe message which can be evaluated and processed by a higher level safety controller. On one side the controller can perform more complex reaction functions, while on the other, the safety function can be used for process monitoring.

► 7.4 Safety functions

7.4.2.4 Safe brake functions

Functions related to holding brakes and service brakes have been summarised under the heading of safe brake functions.



Safe brake functions

Safe brake control (SBC)

Safe brake control (SBC) supplies a safe output signal to drive an external mechanical brake. The brakes used must be “safety brakes”, in which a quiescent current operates against a spring. If the current flow is interrupted, the brake will engage. Control modules frequently include a power reduction feature when the brake is released to reduce energy consumption or brake heating. A safe brake test may be required to detect faults during operation, depending on the risk analysis. Holding brakes or service brakes are often used on axes with suspended loads. Alongside the brake, the brake drive is another key component in terms of the safety function. The safe brake control (SBC) function is normally initiated in conjunction with the STO safety function. Safe brake control influences the entire brake management of the drive axis and should be coordinated with the purely functional requirements.

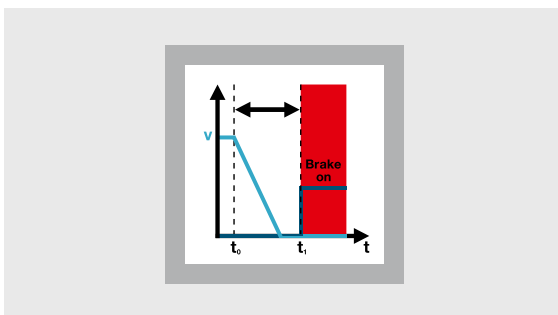

Safe brake control

Safe brake test (SBT)

Mechanical brakes are often used as standard components in safety functions. In that case, the user must carry out a safety assessment and obtain confirmation that the brakes satisfy all requirements relating to a higher-level safety function.

Using the safe brake test (SBT) function significantly increases safety. In many cases, simply controlling a holding brake safely is not enough to make a vertical axis safe. If the wearing, mechanical part of the brake is not maintained regularly, it cannot be guaranteed that the holding brake will apply the designated braking action in the event of danger. The safe brake test (SBT) function provides an automatic test which replaces previous measures that could only be implemented through organisational and manual operations; if the result is negative, it can bring the plant to a standstill and signal a fault. This reduces maintenance work considerably.

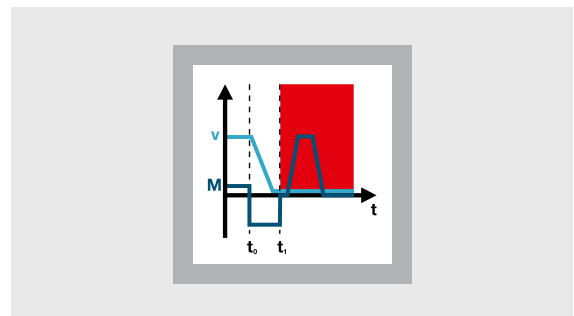

Safe brake test

▶ 7.4 Safety functions

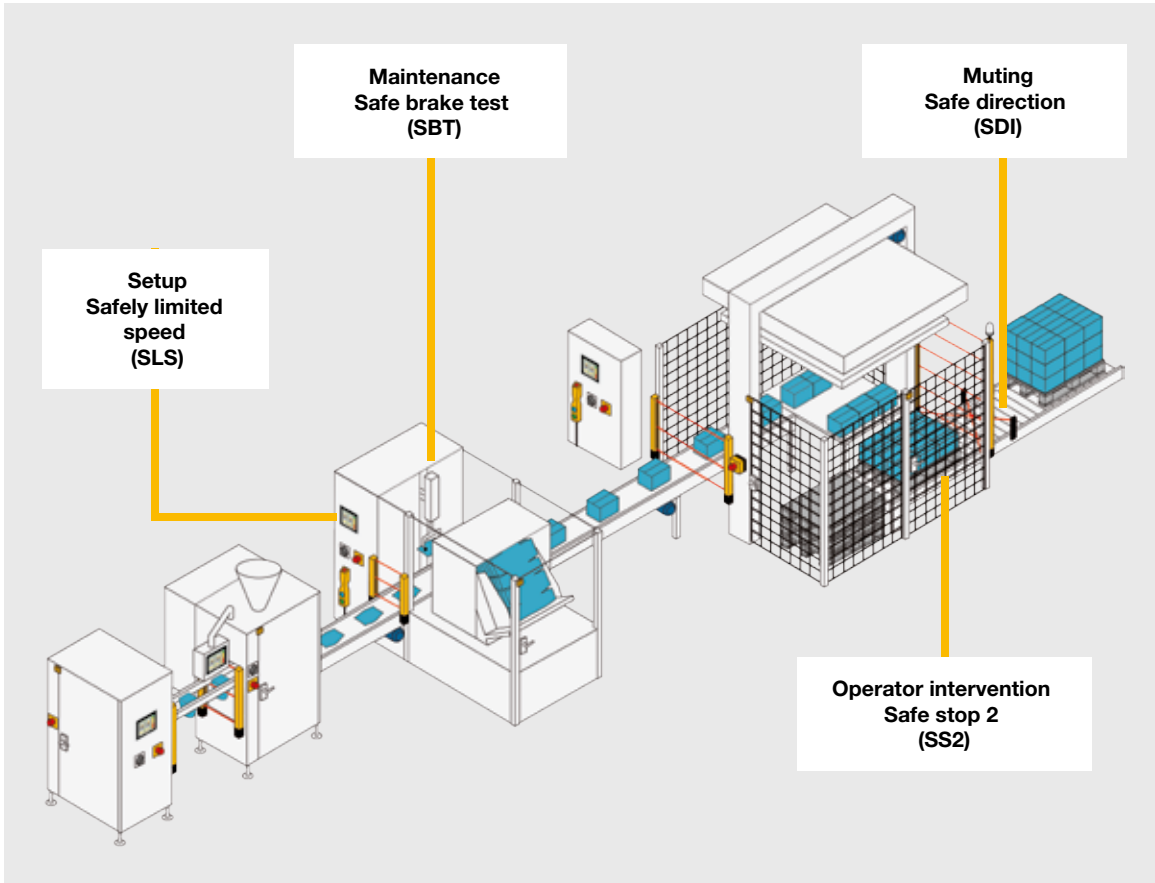

Safety functions using the example of a packaging machine

▶ 7.5 System examination

Safe drive technology merges two issues, which individually already involve a high level of complexity. The challenge is to provide the user with transparent, comprehensible logic in the lifecycle of a safe motion application. The difficulty in configuring and selecting safe drive components is in translating the various influencing factors to

the product requirements. Or to put it another way: in selecting products for an optimum, safe drive solution, which parameters are to be derived from which specifications?

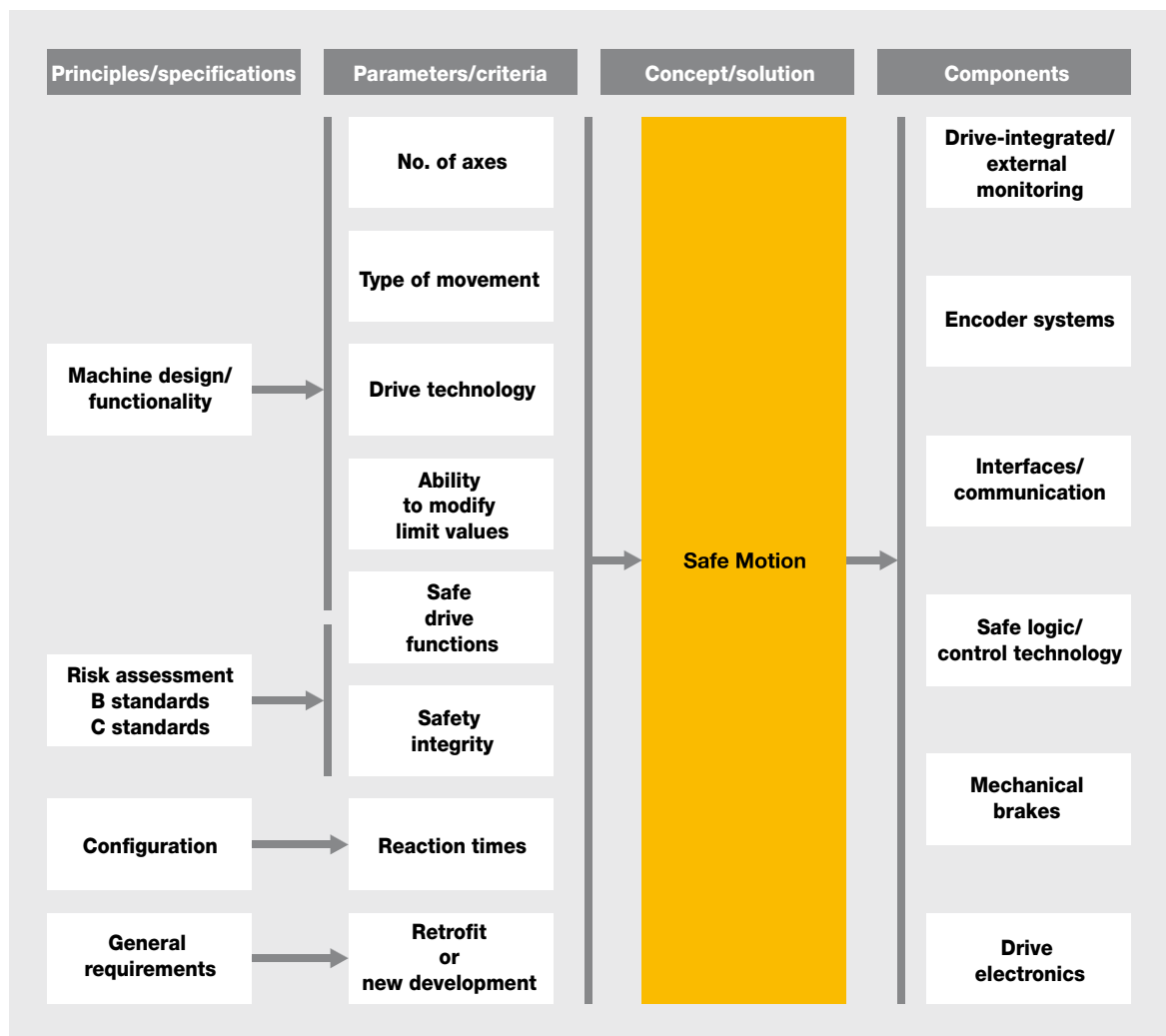

Procedure for configuring and selecting a safe drive solution

▶ 7.5 System examination

The machine design and the functionality demanded by the end customer are essentially the factors that determine which drive technology will be used and how the machine will be operated in control technology terms. The resulting parameters are:

- ▶ How many drive axes?
- ▶ Does the system use servo amplifiers or frequency converters?
- ▶ Are the drives decentralised – i.e. outside the control cabinet?
- ▶ Which safe drive functions are required and how are the parameters to be set?
- ▶ Does the movement to be monitored involve an elliptical curve, synchronous drive axes or, in the simplest case, a single movement?

Specifications from the B and C standards and risk analyses will provide the safety integrity requirement (SIL and PL). These, of course, will also influence the required safety functions. The reaction times of the safe drive components are part of the overall machine design and must be fine-tuned as part of an iterative process. Factors such as stopping performance, safety distances, inertia of the moved mass or the reaction capability of the machine controller play a key role.

General requirements may be whether or not the machine is to be retrofitted with safe drive functions, for example. In some circumstances, existing components must continue to be used, a situation which will often favour an external safety solution. These criteria and parameters must be converted into a concept. The result is a safe drive solution, made up of standard market components.

7.5.1 Drive electronics

These days, modern frequency converters or servo amplifiers have an integrated safe shutdown path, through which the STO safety function can be performed. This shutdown path is generally accessible externally via a terminal pair and must be connected to 24 VDC. If the safety function is not in use, 24 VDC will be available permanently at the terminals. If the shutdown path is used as an STO or safe restart interlock, the terminals must be connected to a safe output on a safety controller or safety relay. In this case, it is important to ensure that the test pulse on the safe output does not initiate the safety function. A countermeasure is to use an input filter with an appropriate time delay. Depending on the version, a feedback path is available for fault detection, to achieve greater safety integrity.

The benefits of a drive-integrated shutdown lie mainly in the

- ▶ Reduced wiring requirement,
- ▶ Rapid restart, as the intermediate circuit remains charged,
- ▶ Short reaction time (measured from the falling edge at the input to the shutdown of the optocoupler, the reaction time is in the millisecond range).

▶ 7.5 System examination

7.5.2 Motor

The relevant properties for the motor in terms of its use in safety-related systems are

- ▶ Type of movement (rotating, linear),
- ▶ Acceleration capability (inert asynchronous motor or air-borne linear drive),
- ▶ Integrated motor encoder,
- ▶ Integrated holding brake incorporated into the safety concept.

The motor's acceleration capability influences the system's maximum permitted overall reaction time. Highly dynamic linear motors have extremely low electrical time constants on the winding and a high overload capability, so that a multiple of the rated power is present in just a few milliseconds. Resolvers are widely used as motor encoders in servo drive technology. They are used in rotating motors and are both robust and economical. The measuring system provides an absolute position within a motor rotation, but has limited resolution due to the function principle. Only rarely can resolver signals be evaluated by safe monitoring components. For this reason, motor encoder systems with sine/cosine analogue tracks are preferable in safety-related applications with motion monitoring. Motor encoder systems with an all-digital interface can only be monitored using special manufacturer-specific safety components. Third party products cannot be connected.

7.5.3 Safe logic

Safety relays or safety controllers can perform the following tasks in systems with safe drive functions, depending on the application:

- ▶ Evaluation of sensors on safeguards
- ▶ Activation of safety functions,
- ▶ Drive shutdown
- ▶ Evaluation of the status of safely monitored drive axes in a multi-axis system
- ▶ Establishing the plant's overall safety
- ▶ Specifying new limit values during operation
- ▶ Interface between the drive controller and the safety functions

The safe logic can be implemented either as separate, external components or as drive-integrated components. Safe logic is the interface between the sensors on the safeguards and the safe monitoring unit. Drive-integrated solutions enable simple functions in single axis systems to be implemented economically. Sensors are connected directly on the drive and are evaluated. The limited number of safe interfaces makes cross-communication between the drives as well as complex logic links impossible. The cycle time of the safety controller must always be included in the assessment of the overall reaction time if pre-processing in safe logic is required in order to activate a safety function. Depending on the size of the user program, this will range between 50 and 200 ms and therefore dominates over the delay in the shutdown path. It is also necessary to consider a delay time on safe, digital inputs; this arises due to the input filters.

▶ 7.5 System examination

7.5.4 Safe braking

Mechanical brakes must be used if the output shafts on motors or gearboxes are affected by forces that would trigger movement when the motor was shut down. Example applications are vertical axes or motors with high inertia. The operation of vertical axes is a special case as far as safety technology is concerned. The failsafe principle – the removal of power to the drives in the event of a fault – is generally applied in safety technology, but in this case it would not lead to a safe condition because falling loads present a hazard. Mechanical brakes are incorporated to rectify this; their functionality must be constantly verified using special proof tests. As with the encoder systems, various versions are available to fit the specific safety requirements. Dual channel capability can be implemented either through two independent brakes or through a brake with two separate brake circuits. The advantage of two separate brakes is that faults can be covered within the mechanical transmission elements between the drive and the process. The brake configuration depends largely on the machine design and the overall safety concept.

7.5.5 Motion monitoring

Motion monitoring has two main tasks: it must detect any violation of the limit values and then trigger an appropriate reaction function. It must also detect any potential faults on the encoder system and likewise trigger an appropriate error reaction function. Both functions are heavily linked to the availability of the drive system. Noisy signals or poorly tuned control loops can cause sensitive monitoring mechanisms to trigger reaction functions and therefore reduce plant availability. Proper shielding of the motor and encoder cables is absolutely essential. The algorithms for the monitoring functions can be applied via hysteresis or filter settings. The reaction times for these components are in the millisecond range. Motion monitoring is available as both an external and a drive-integrated solution. An integrated solution has clear advantages over an external device in terms of wiring effort and convenience. Disadvantages are higher retrofitting costs for existing plants and dependence on the converter that is used. This means that the technical properties of the drive, as well as the interfaces and the performance of the safety functions, have to fit the application. With an external monitoring unit, safety functions can be implemented as standard on frequency converters and servo amplifiers of a different performance class or manufacturer.

► 7.5 System examination

7.5.6 Motion control

With the current state-of-the-art technology, motion control is a non-safety-related drive component. Depending on the task, the functions are either drive-integrated or are performed by an external

controller via fieldbus or drive bus. The classic allocation between the controllers depends on the required movement.

Movement	Controller	Safe motion monitoring
Positioning of a single axis	Positioning controller	Drive-integrated or external monitoring of single axis
Electronic cam disk (synchronous motion)	Motion controller	Limit value and monitoring must be examined for each drive axis. The status conditions of the individual axes are evaluated in central, safe logic.
Elliptical curve (resulting motion)	NC or RC controller	Safe, central calculation of the current position from the position of the individual axes

7.5.7 Implementation examples

Servo converters with drive-integrated motion monitoring and safe pulse disabler for shutdown

Sensor evaluation is undertaken, for example, by a small, safety-related controller, which activates the safety functions in the drive via a

safe I/O interconnection. The servo motor has an integrated sine/cosine motor encoder for motor control and positioning. The reaction time before the safety function is activated is around 60 ms, the reaction time when limit values are violated is <10 ms.

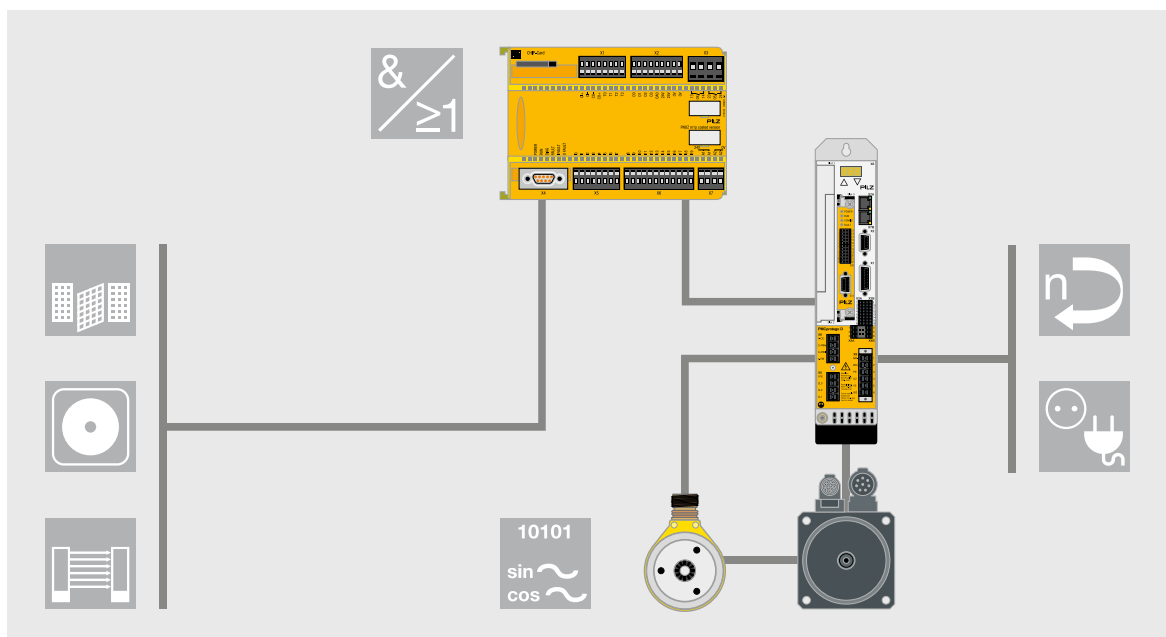

Implementation example with servo amplifier

► 7.6 Examples of safe motion

7.6.1 Performance level of safety functions

7.6.1.1 Normative basis

Several standards (generic safety standards and technical safety standards; type A and type B standards) are available for determining the safety level achieved by the safety-related part of a controller. EN ISO 13849-1 is generally applied in the engineering sector. For many machines, the safety level to be achieved can be taken from the respective machinery safety standards (type C standards); (e.g. presses → EN 692, EN 693; robots → EN ISO 10218-1, packaging machinery → EN 415). If there are no C standards for a product, the requirements can be taken from the A and B standards.

7.6.1.2 Safe stop function

The safety function “E-STOP when light curtain is interrupted” is addressed here by the example below; it illustrates a safe stop function for a motor-driven axis. The methodology described below is based on EN ISO 13849-1 and as such can only be applied if all the safety function subcomponents have their own performance level. Using the terminology of the standard, it is a series connection of safety-related parts of a controller (SRP/CS).

This example uses a light curtain, a configurable safety controller and a servo amplifier with integrated safety functions. A servo motor with feedback system is connected to the servo amplifier.

The risk analysis permits a stop category 1 for the axis.

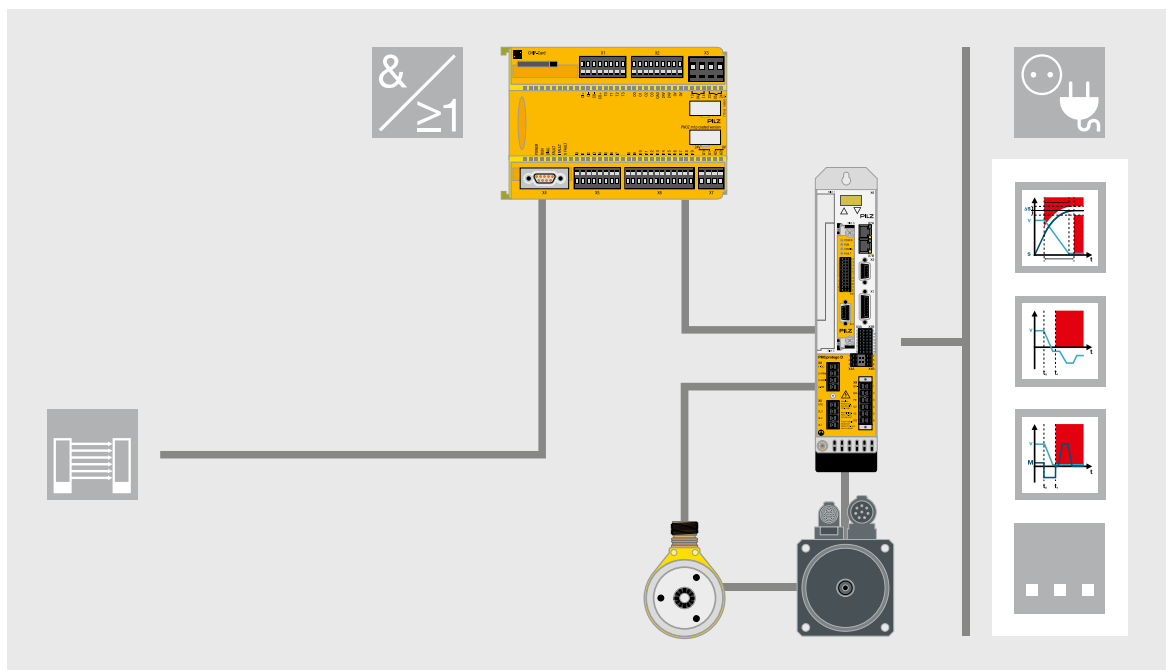

Structure of the safety function

▶ 7.6 Examples of safe motion

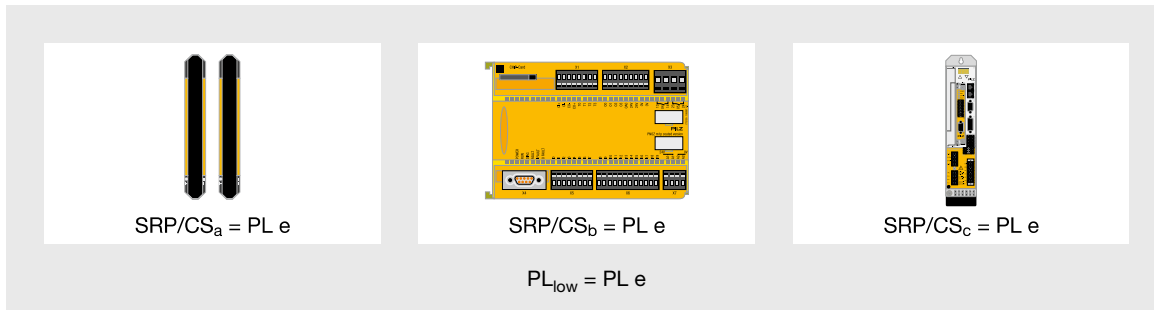

The block diagram shows the logical structure of the safety function, comprising the series connection of the safety-related subcircuits.

Determination of the performance level for the overall circuit

EN ISO 13849-1: Table 11 – Calculation of PL for series connection of SRP/CS

PL_{low}	N_{low}	→	PL
a	> 3	→	None, not allowed
	≤ 3	→	a
b	> 2	→	a
	≤ 2	→	b
c	> 2	→	b
	≤ 2	→	c
d	> 3	→	c
	≤ 3	→	d
e	> 3	→	d
	≤ 3	→	e

Note: the values calculated for this look-up table are based on reliability values at the mid-point for each PL.

In the example of the safe stop function, all three components involved have performance level e. As a result, the lowest performance level of a safety-related subcircuit (SRP/CS) is also PL e. Using the standard's terminology, therefore, we have:

- ▶ 3 x SRP/CS each with PL e
- ▶ The lowest performance level of the 3 subcircuits (SRP/CS) is PL e and is assigned the parameter PL_{low} .
- ▶ The lowest performance level occurs in 3 subcircuits and so the parameter $N_{low} = 3$.

If you apply this information to Table 11 of the standard, the result for the example is an overall classification of PL e.

► 7.6 Examples of safe motion

7.6.1.3 Safe stop function on vertical axes

If you examine the potential risks on servo axes you'll see that a vertical axis is also a good example for increasing awareness of the mechatronic view. Removal of power is not enough to bring an axis to a safe condition. In many cases, the load's own weight is enough for it to fall. Mass and friction will determine the speed that occurs in the process. As part of the risk analysis, potential hazards are analysed in the various machine operating modes and as operators carry out their work. The required measures will then be derived from this analysis. With vertical axes, the measures that need to be taken will essentially depend on whether the

full body of the operator can pass below the vertical axis or whether just his arms and hands are positioned below the vertical axis. Another aspect is the frequency and duration of his stay in the danger zone. All these factors are added up to give the "performance level" that the safety functions must achieve.

Building on the "Safe stop function" example, a brake is added to the structure. Holding brakes and service brakes are both common.

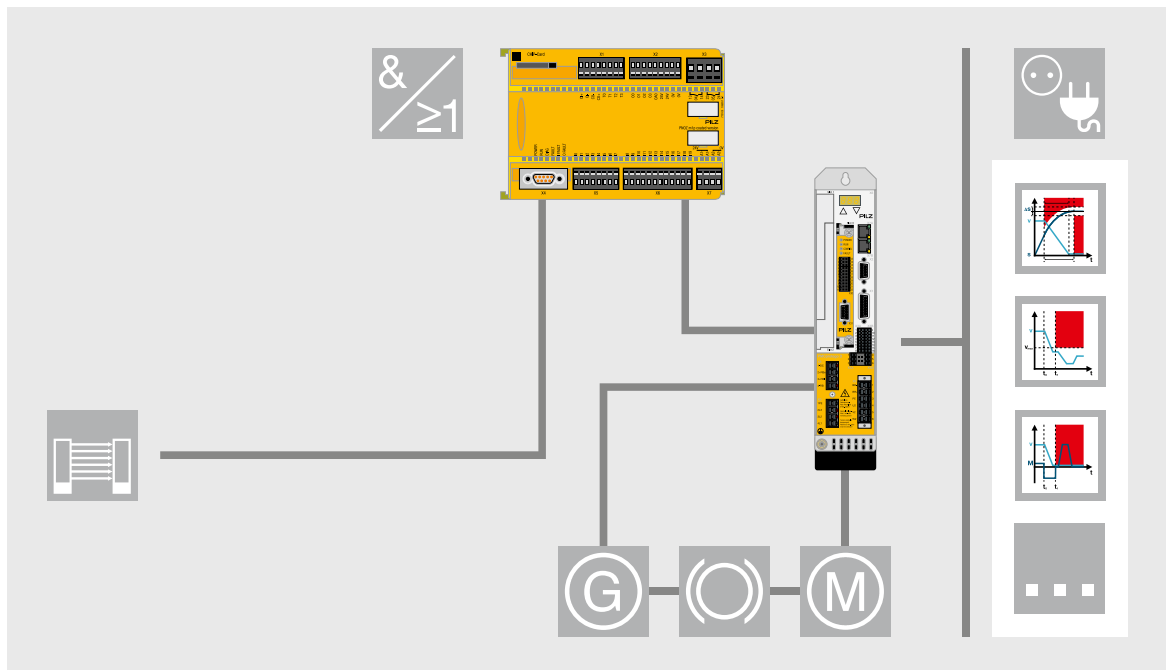

Structure of the safety function

► 7.6 Examples of safe motion

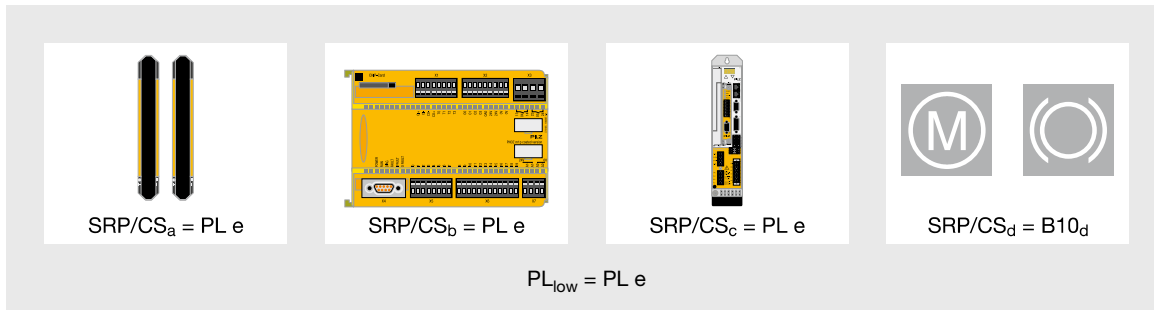

The block diagram shows the logical structure of the safety function, comprising the series connection of the safety-related subcircuits.

Determination of the performance level for the holding brake

Here the user of EN ISO 13849-1 is confronted with one of the positive approaches of this standard. The standard not only enables examination of the electrical part of the safety function, but also of the mechanical, hydraulic and pneumatic section.

However, the holding brake used in this example does not have a performance level, as this is only available for intelligent components. Brake manufacturers can only provide a B10_d value, as they do not know how exactly their components will be used in the application and so can only make a statement regarding the number of operations before a component failure. The design engineer constructing the safety-related part of the controller must now calculate the time to a dangerous failure of the component. The B10_d value is not the only consideration in this calculation; the mean time between two consecutive cycles is also a key factor which influences the MTTF_d value.

$$MTTF_d = \frac{B_{10d}}{0,1 \times n_{op}}$$

$$n_{op} = \frac{d_{op} \times h_{op} \times 3600 \text{ s/h}}{t_{Zyklus}}$$

The following assumptions are made, based on the application of the component:

- ▶ h_{op} is the mean operating time in hours per day.
- ▶ d_{op} is the mean operating time in days per year.
- ▶ t_{cycle} is the mean time between the start of two consecutive cycles of the component (e.g. switching a valve) in seconds per cycle.

Assuming that the calculation of the MTTF_d for the holding brake results in a value of > 100 years, this gives an MTTF_d classification of "HIGH". EN ISO 13849-1 provides a graph to make it easier to determine the performance level. To decipher the performance level from this graph the diagnostic coverage DC is required. To determine the level of diagnostic coverage it is important to know whether every conceivable fault can be detected through tests. Based on this consideration, a high classification will be possible if a safe converter is used to drive the motor and the holding brake is tested automatically before the danger zone is accessed. To do this, a torque is established with a factor of 1.3 to the brake's rated holding torque, before waiting for at least one second. If the axis holds its position during the whole test, it can be assumed that the holding brake is in good working order. On this basis, it is possible to define the diagnostic coverage at 99%.

▶ 7.6 Examples of safe motion

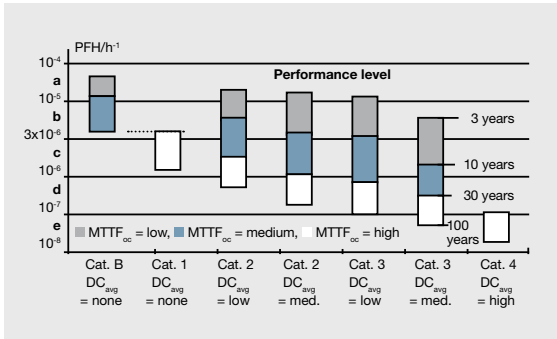

Graph to determine the PL in accordance with EN ISO 13849-1

So we now have the following data:

- ▶ Category = 4
- ▶ MTTF_d = high
- ▶ DC = high

If this data is applied to the graphic, PL e can be determined.

Determination of the performance level for the overall circuit

In the illustrated example of the safe stop function on a servo axis with holding brake, all four components involved have performance level e. As a result the lowest performance level of a subcircuit (SRP/CS) is also PL e. Using the standard's terminology, therefore, we have:

- ▶ 4 x SRP/CS each with PL e
- ▶ The lowest performance level of the 4 subcircuits (SRP/CS) = PL e and is assigned the parameter PL_{low}.
- ▶ The lowest performance level occurs in 4 subcircuits and so the parameter N_{low} = 4.

If this information is applied to Table 11 of EN ISO 13849-1 for a simplified calculation, the result for the example is an overall classification of PL d. Unlike the example for the safe stop function (without brake), a reduction factor now applies: in accordance with EN/ISO 13849-1, the achieved performance level is reduced by one level if the overall circuit contains more than three subcircuits with PL_{low}. However, in this case a detailed calculation using the achieved PFH_D values can certainly result in PL e. This is where software tools such as the PASCAL Safety Calculator come into their own.

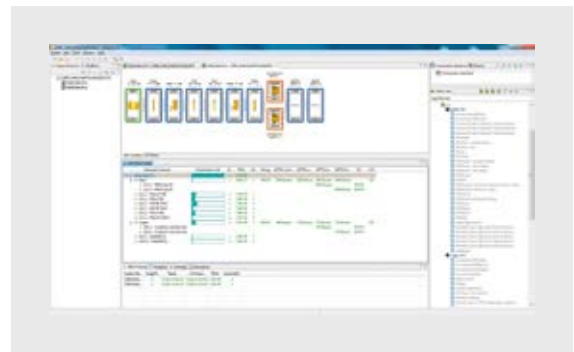

PASCAL Safety Calculator

▶ 7.6 Examples of safe motion

7.6.1.4 Jog function with safely limited speed (SLS)

These days, jog functions can generally be carried out while guards are open thanks to the safely limited speed (SLS) function. The respective application will determine the type of increment that can be classified as non-hazardous. It may be helpful to consult EN 349 and EN ISO 13855.

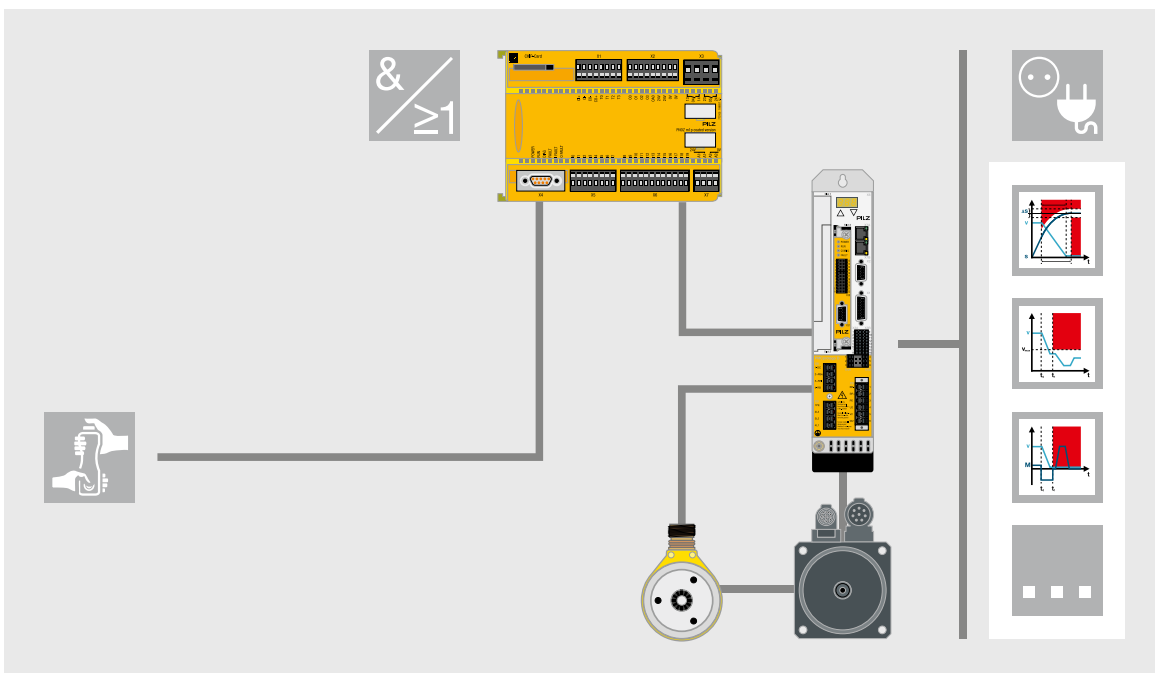

Structure of the safety function

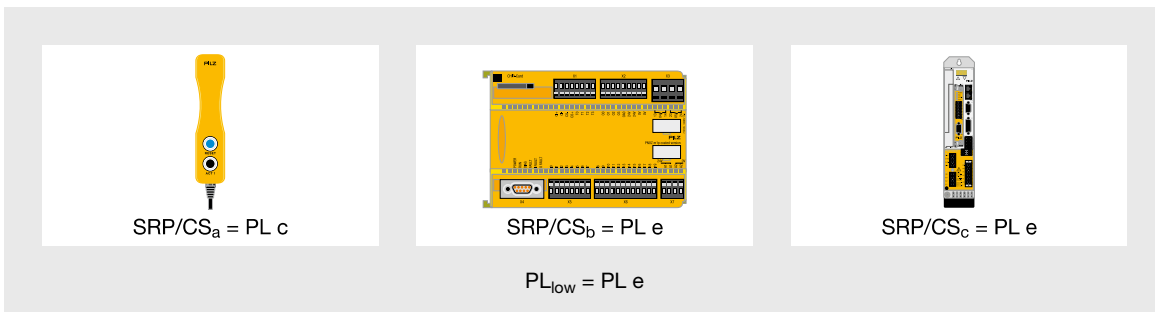

The block diagram shows the logical structure of the safety function, comprising the series connection of the safety-related subcircuits.

▶ 7.6 Examples of safe motion

Determination of the performance level for the overall circuit

In terms of structure, the jog function with safely limited speed (SLS) is similar to the safe stop function described in section 7.6.1.2. The key difference lies in the pushbuttons used for the jog function and the impact this has on the calculation of the performance level. In EN ISO 13849-1, pushbuttons (enabling switches) are given a B_{10d} of 100,000. The time between two operations (cycles) is the key factor in calculating the $MTTF_d$.

Calculation formula for $MTTF_d$

$$MTTF_d = \frac{B_{10d}}{0,1 \times n_{op}}$$

$$n_{op} = \frac{d_{op} \times h_{op} \times 3600 \text{ s/h}}{t_{\text{Zyklus}}}$$

The following assumptions are made, based on the application of the component:

- ▶ h_{op} is the mean operating time in hours per day.
- ▶ d_{op} is the mean operating time in days per year.
- ▶ t_{cycle} is the mean time between the start of two consecutive cycles of the component (e.g. switching a valve) in seconds per cycle.

Assumptions:

- ▶ $B_{10d} = 100,000$
- ▶ $h_{op} = 16 \text{ h/day}$
- ▶ $d_{op} = 220 \text{ d/year}$

Calculation $MTTF_d$:

- ▶ $t_{\text{cycle}} = 5 \text{ s} \rightarrow MTTF_d = 0.395 \text{ years}$
- ▶ $t_{\text{cycle}} = 3,600 \text{ s} \rightarrow MTTF_d = 284.1 \text{ years}$

As shown in the example with cyclical operation in 5 s intervals, even in the best case it is only possible to achieve PL c with a B_{10d} value of 100,000. This demonstrates very clearly that the application range for wearing components has a direct influence on the calculation of the performance level and therefore affects the achievable safety level. The design engineer must therefore look very closely at the application range of his components in the respective application. Even if EN ISO 13849-1 states 100,000 cycles for B_{10d} , there may well be special components with a higher B_{10d} value. If an application uses a pushbutton as an E-STOP command device, it will certainly not be operated constantly at 5 second intervals. The situation is completely different if a pushbutton is used as a command device for cyclic initiation of a machine cycle and has to trigger a safe stop once released. The values stated in the example may cause a problem if a higher performance level is required.

► 7.6 Examples of safe motion

7.6.1.5 Muting with safe direction (SDI)

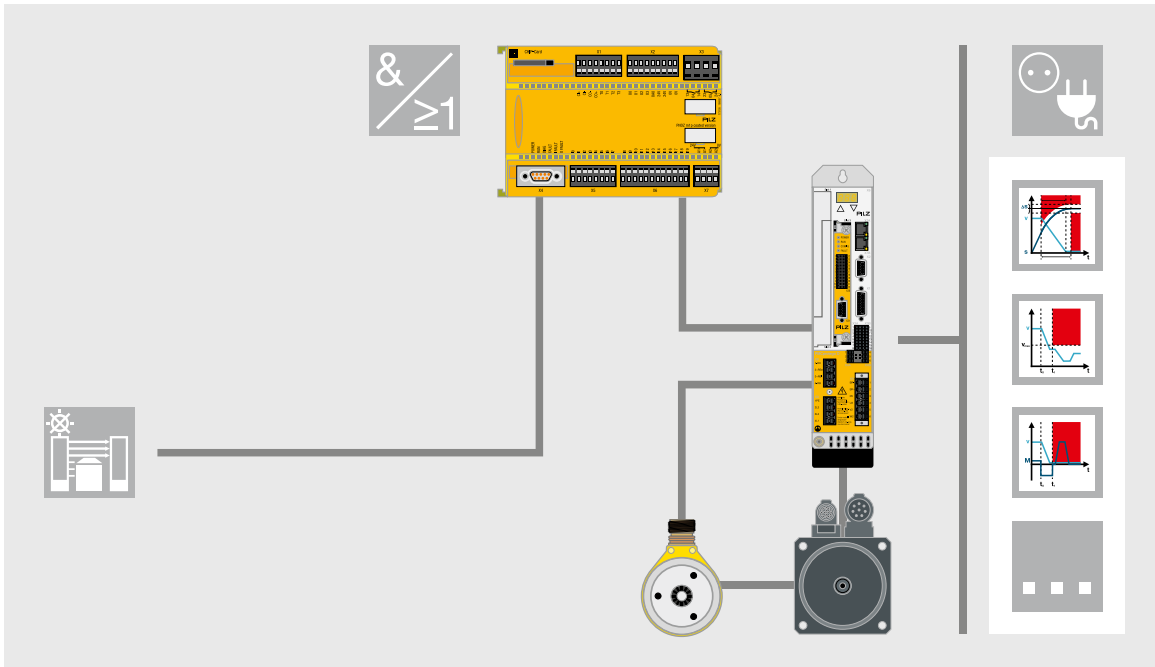

Structure of the safety function

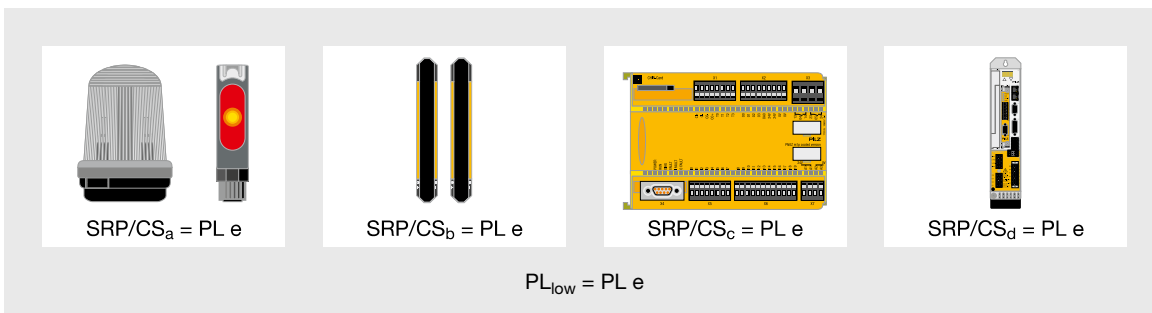

The block diagram shows the logical structure of the safety function, consisting of the series connection of the safety-related subcircuits (SRP/CS).

In conjunction with light curtains and a muting circuit, the safe direction function (SDI) has a positive effect on safety because the respective direction of the drive axis is monitored during the muting phase and a safe shutdown occurs in the event of a fault.

Determination of the performance level for the overall circuit

The performance level corresponds to the result from the example of the safe stop function.

▶ 7.6 Examples of safe motion

7.6.1.6 Motion monitoring with external devices

Drive-integrated motion monitoring is accompanied by external monitoring. In the simplest case, the drive has no safety function. A drive can be shut down in order to implement a safety function via conventional means, using contactors for example. However, today's drives often already have an STO function and can therefore implement a "safe stop". So an upstream safety relay can ensure that the hazardous movement is shut down simply and safely. Actual safety-related motion monitoring takes place in the external monitoring component, however.

The task of the external devices is to detect motion. The safety characteristic data of the employed sensors, e.g. encoders or proximity switches, is significant in determining the safety level that can be achieved. Different solutions to suit the various requirements are available to monitor movements with external monitoring devices. At the highest level it is necessary to distinguish between so-called standard encoders and "safe" encoders. When standard encoders are used, it is important to determine whether one or two encoders are required.

The following safety functions may be realised, for example, depending on the monitoring functions implemented in the external monitoring devices:

- ▶ Safely limited speed (SLS)
- ▶ Safe direction (SDI)
- ▶ Safe operating stop (SOS)
- ▶ Safe speed range (SSR)
- ▶ Safely limited acceleration (SLA)
- ▶ Safe acceleration range (SAR)

The following examples illustrate potential types of motion monitoring using external devices. For the sake of clarity, the examples only illustrate those motion monitoring components with the task of monitoring motion sensors such as encoders or proximity switches. The basic calculation method corresponds to the one illustrated in the previous examples.

▶ 7.6 Examples of safe motion

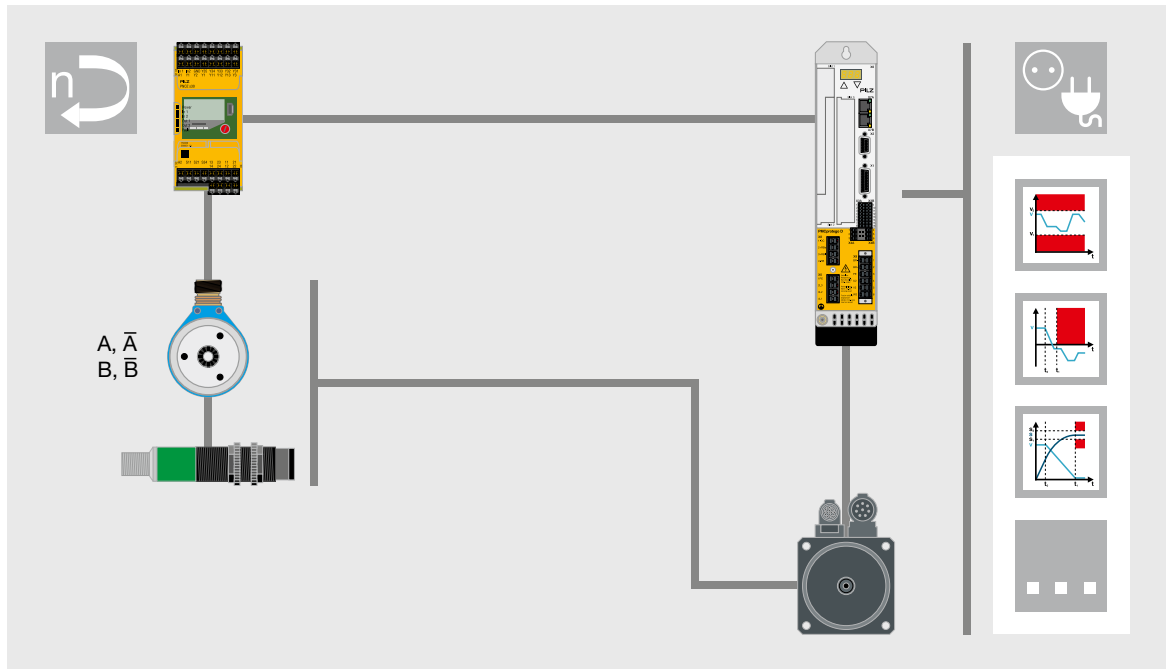

Motion monitoring with redundant standard sensors

7.6.1.8 External motion monitoring with standard encoder and proximity switch

Generally speaking, two separate sensors for motion detection are required in order to achieve the highest safety level (PL e) with standard sensors. Depending on the external monitoring device, these may be two encoders or, as shown in this example, one encoder and an additional proximity switch. The corresponding values for $MTTF_d$ are required for the sensors. This enables the performance level to be calculated for the sensor subsystem, which consists of the encoder and proximity switch; this can then be used to calculate the performance level for the overall safety function. The hazardous function is shut down via an STO function available within the drive.

The encoder signals evaluated by the monitoring device for the safety function can also be used by the drive controller for speed and position control. However, this is not absolutely essential for the safety function. The following safety functions are possible with the illustrated configuration:

- ▶ Safely limited speed (SLS)
- ▶ Safe direction (SDI)
- ▶ Safe operating stop (SOS)
- ▶ Safe speed range (SSR)
- ▶ Safely limited acceleration (SLA)
- ▶ Safe acceleration range (SAR)

Note: the safety functions that can be realised depend on the monitoring functions implemented in the external monitoring device.

► 7.6 Examples of safe motion

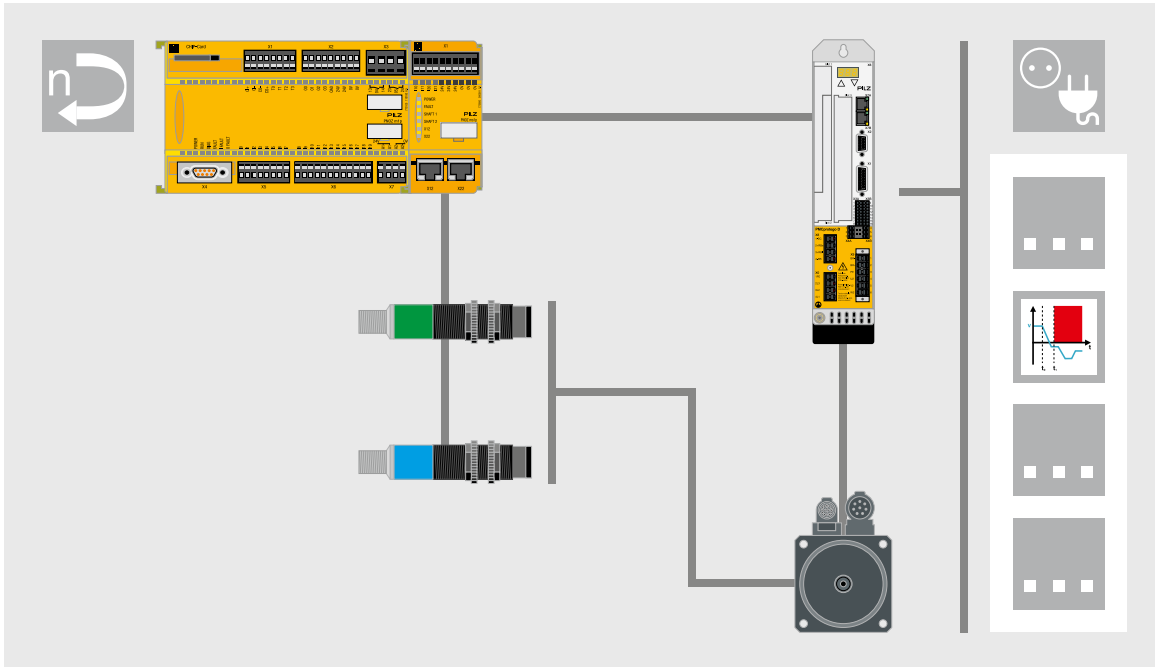

Motion monitoring with proximity switches

7.6.1.9 External motion monitoring with two standard proximity switches

Without an encoder, safety-related motion monitoring can still be implemented using standard sensors in the form of proximity switches, even up to the highest safety level (PL e). As in the previous example, two separate proximity switches are required for motion detection. If common cause failures (CCF), due to EMC for example, cannot be excluded or managed on both proximity switches, the use of diverse components from different manufacturers or of different types is recommended. The corresponding values for $MTTF_d$ are required for the proximity switches. This enables the performance level to be calculated for the sensor subsystem, which consists of the two proximity switches; this can then be used to calculate the performance level for the overall safety function. The hazardous function is shut down via an STO function available within the drive.

The following safety function is possible with the illustrated configuration:

- Safely limited speed (SLS)
- Safe speed range (SSR)

Note: the safety functions that can be realised depend on the monitoring functions implemented in the external monitoring device.

▶ 7.6 Examples of safe motion

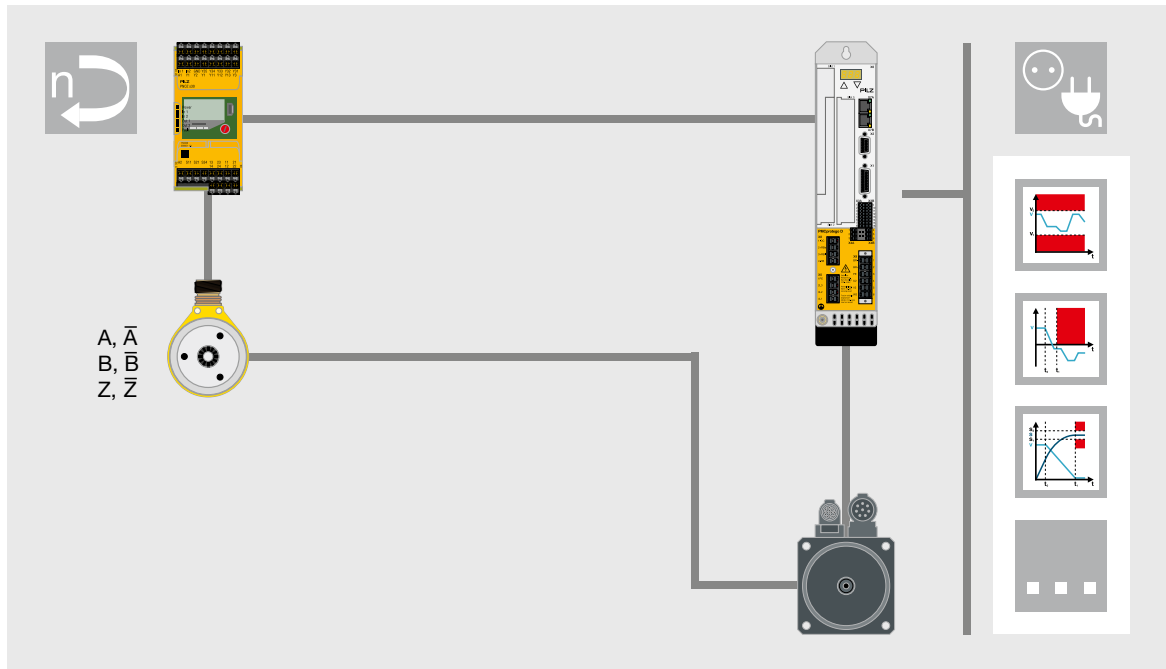

Motion monitoring with safe encoder

7.6.1.10 External motion monitoring with safe encoder

Manufacturers are increasingly offering “safe” encoders for motion monitoring tasks. These devices are designed specifically for use in safety functions and are certified accordingly. As a result, a performance level of PL d or PL e can be achieved, depending on the construction type. This is usually possible with just one encoder, i.e. there is no need for two devices, as is the case when standard components are used. However, safe encoders are not actually “safe” until they are combined with a safe monitoring device, because there are no diagnostic or feasibility tests implemented within the encoder. The use of safe encoders therefore requires detailed knowledge of the requirements for use in safety-related applications, as described by the manufacturer in the operating manual. The monitoring device must be able to meet these requirements exactly by performing the monitoring functions demanded by the device manufacturer.

One test that is often demanded, for example, is the absolute value check for sin/cos encoders: $\sin^2 + \cos^2 = 1$. If this check is not implemented within a monitoring device, the device cannot be used in combination with a safe encoder that requires such a check. To date there is still no uniform or even standardised interface for safe encoders, so the encoder manufacturers’ requirements for their products vary enormously. That’s why it is absolutely essential that the safe encoder and safe monitoring device are totally compatible. In this example, the hazardous movement is shut down via the STO function available within the drive. The following safety functions can be implemented with the illustrated configuration:

- ▶ Safely limited speed (SLS)
- ▶ Safe direction (SDI)
- ▶ Safe operating stop (SOS)
- ▶ Safe speed range (SSR)
- ▶ Safely limited acceleration (SLA)
- ▶ Safe acceleration range (SAR)

Note: details of the safety functions that can be realised depend on the monitoring functions implemented in the external monitoring device.

▶ 7.6 Examples of safe motion

7.6.1.11 Safeguarding detection zones with a safe camera-based solution

Until now, interaction between man and robot has largely been characterised by fixed safeguards. A modern camera-based solution offers a whole range of new options in this case. The detection zone covers all three dimensions; one single device

meets every requirement when accessing a danger zone and also provides protection against climbing over and crawling under the detection zone. The detection zones can be individually configured and can also enable the speed of the active axes in the monitored zone to be reduced if anyone approaches.

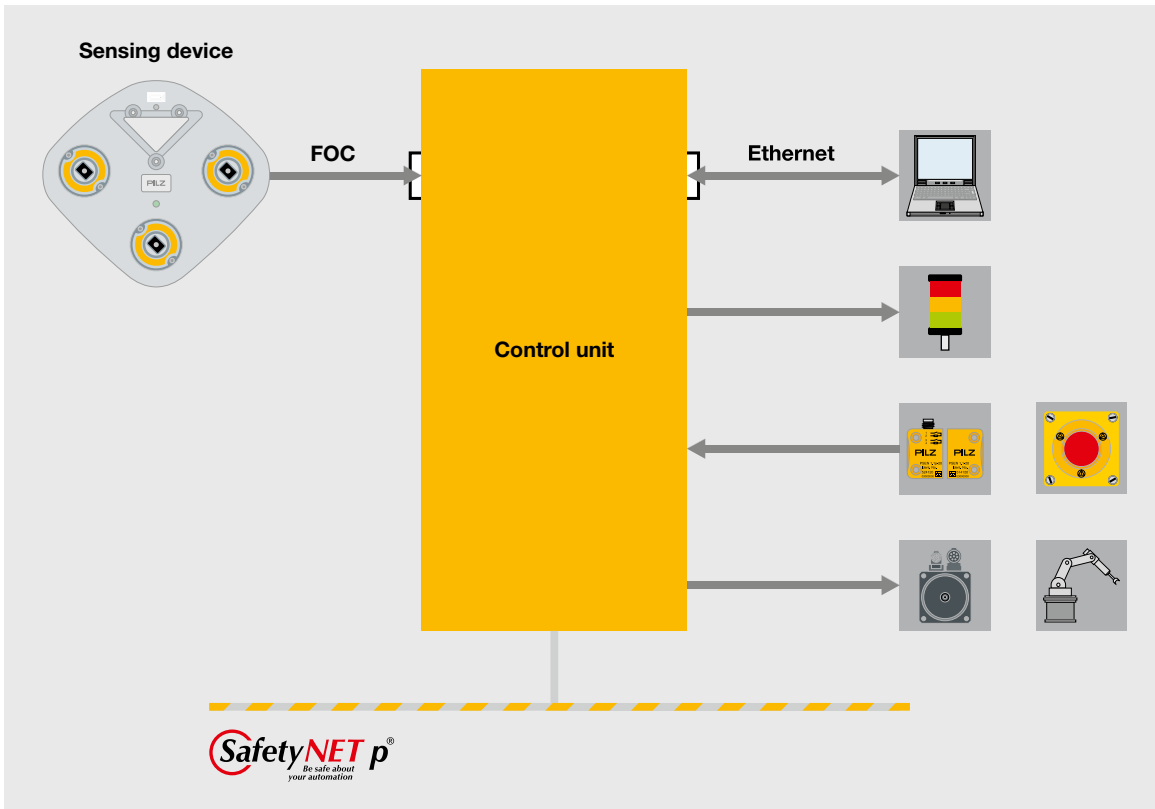

Structure of the safety function

▶ 7.6 Examples of safe motion

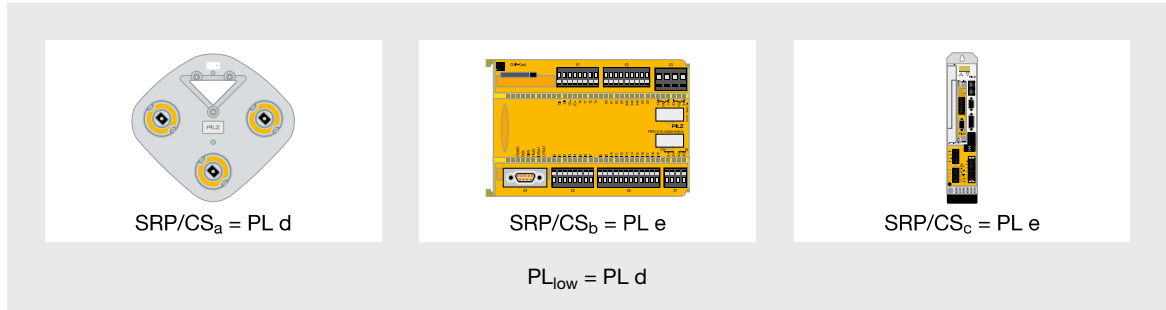

Block diagram of the safety functions

Determination of the performance level for the overall circuit

The result is performance level d.

7.6.2 Reaction times of safety functions

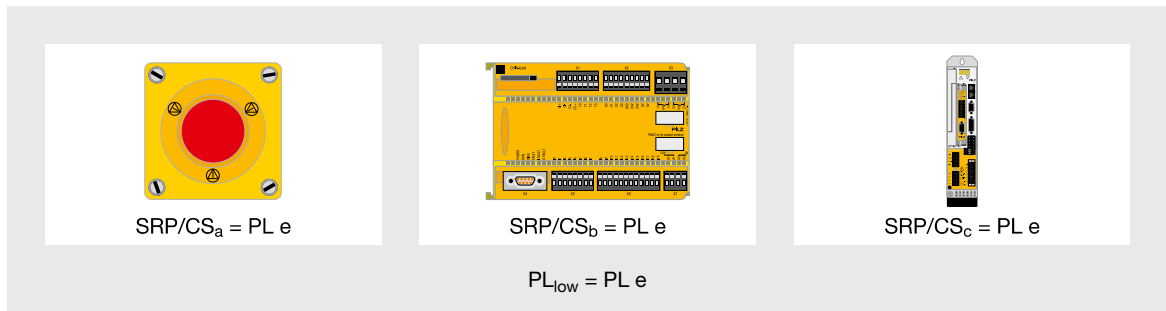

Block diagram of the safety functions

Several boundary conditions are used in calculating a safety distance.

Determination of the reaction time in the case of external commands

If an E-STOP pushbutton acts upon an evaluation device, its reaction time is added to the reaction time of the drive-integrated safety function. It will also be necessary to add the time needed to bring an accelerated axis to standstill:

- ▶ $t_{\text{reac}} = t_{\text{multi}} + t_{\text{PMC}} + t_{\text{ramp}}$
- ▶ t_{multi} = Reaction time of the evaluation device is approx. 20 ms

- ▶ t_{PMC} = Reaction time of the drive-integrated safety functions to external signals is 6 ms
- ▶ t_{ramp} = Ramp time to standstill depends on the moved mass, speed and other application-dependent data

Determination of the reaction time when limit values are violated

If a monitoring circuit on a drive-integrated safety function is activated, it will be necessary to add the time needed to bring the accelerated axis to standstill.

- ▶ $t_{\text{reac}} = t_{\text{PMC}} + t_{\text{ramp}}$



8

Mechanical,
pneumatic
and hydraulic
design



▶ 8 Mechanical, pneumatic and hydraulic design

8	Mechanical, pneumatic and hydraulic design	
8.1	Introduction to mechanical, pneumatic and hydraulic design	8-3
8.2	Mechanical design	8-4
8.2.1	Introduction	8-4
8.2.2	Danger, hazard, risk	8-5
8.2.3	Definition and implementation of safety measures	8-9
8.3	Pneumatic design	8-21
8.3.1	Relevant units	8-21
8.3.2	Introduction	8-23
8.3.3	Well-trying principles and protective measures	8-23
8.3.4	Circuit-based solutions	8-27
8.3.5	Stopping and braking	8-33
8.3.6	Circuit diagram and operating manual	8-35
8.4	Hydraulic design	8-37
8.4.1	Basic physical knowledge	8-37
8.4.2	Advantages of hydrostatic power transmission	8-37
8.4.3	Disadvantages of hydrostatic power transmission	8-37
8.4.4	Definitions	8-37
8.4.5	General hydraulic relationships	8-38
8.4.6	Structure of a hydraulic system	8-44
8.4.7	Simple hydraulic circuit, upward movement	8-44
8.4.8	Simple hydraulic circuit, downward movement	8-45
8.4.9	Simple hydraulic circuit, speed	8-45
8.4.10	Circuit diagram for a simple hydraulic circuit	8-46
8.4.11	Two-cylinder controllers with electric valves	8-47
8.4.12	Two-cylinder controllers with sequence valves	8-48
8.4.13	Series circuit	8-49
8.4.14	Parallel circuit	8-49
8.4.15	Differential circuit	8-50
8.4.16	Speed controllers	8-51
8.4.17	Drive pumps, fixed pumps	8-52
8.4.18	Drive pumps, screw pumps	8-53
8.4.19	Drive pumps, vane pumps	8-54
8.5	Safety requirements on hydraulic circuits	8-55
8.5.1	Safety requirements in general	8-55
8.5.2	Concept and design	8-55
8.5.3	Additional safety requirements	8-55
8.5.4	Establishing compliance with the safety requirements	8-56
8.5.5	Safety-related parts of hydraulic controllers	8-57
8.5.6	Controllers in accordance with Category B, Performance Level a as per EN/ISO 13849-1	8-58
8.5.7	Controllers in accordance with Category 1, Performance Level b	8-59
8.5.8	Controllers in accordance with Category 2, Performance Level b	8-60
8.5.9	Controllers in accordance with Category 3, Performance Level d	8-61
8.5.10	Controllers in accordance with Category 4, Performance Level e	8-62
8.5.11	Further example for controllers in accordance with Category 4	8-63

▶ 8.1 Introduction to mechanical, pneumatic and hydraulic design

Safety technology is consistently gaining in importance in the design of plant and machinery. Although machinery may have already been fitted with a high level of safety measures, with rising demands on efficiency and productivity, safety technology continues to develop on an ongoing basis. The Machinery Directive plays a significant role in this. The following three chapters deal with mechanics, pneumatics and hydraulics. However, all three drive technologies should also always be considered in combination with the electrical design.

▶ 8.2 Mechanical design

8.2.1 Introduction

Engineers and designers have always done a good job. How else could you explain the remarkable level of safety on today's plant and machinery? The considerable maelstrom surrounding the EC Machinery Directive (MD) has not actually been based on (safety) technology. It has been much more concerned with the fact that a member of the company's management team must now use his good name to guarantee that the supplied machine actually has the necessary level of safety demanded and, what's more, that this can be proved legally (key words are documentation and operating manual). However, it's important to get one thing straight:

Our machines are still not always perfect, but they are continuously getting better. Evolution in safety technology does not mean the implementation of wholly new solutions; quite the opposite: Deficiencies provide the impetus for improvement and errors the premise for correction!

Regarding terminology: In general parlance, the distinction between reliability and safety is not always clear. That is because both terms have some things in common: They refer to future events and deal with probability. From the perspective of work safety and the associated safety-related design, a distinction should be made between the two terms, using exclusive definitions: If a component (or even a module, machine or plant) does not fulfil its intended

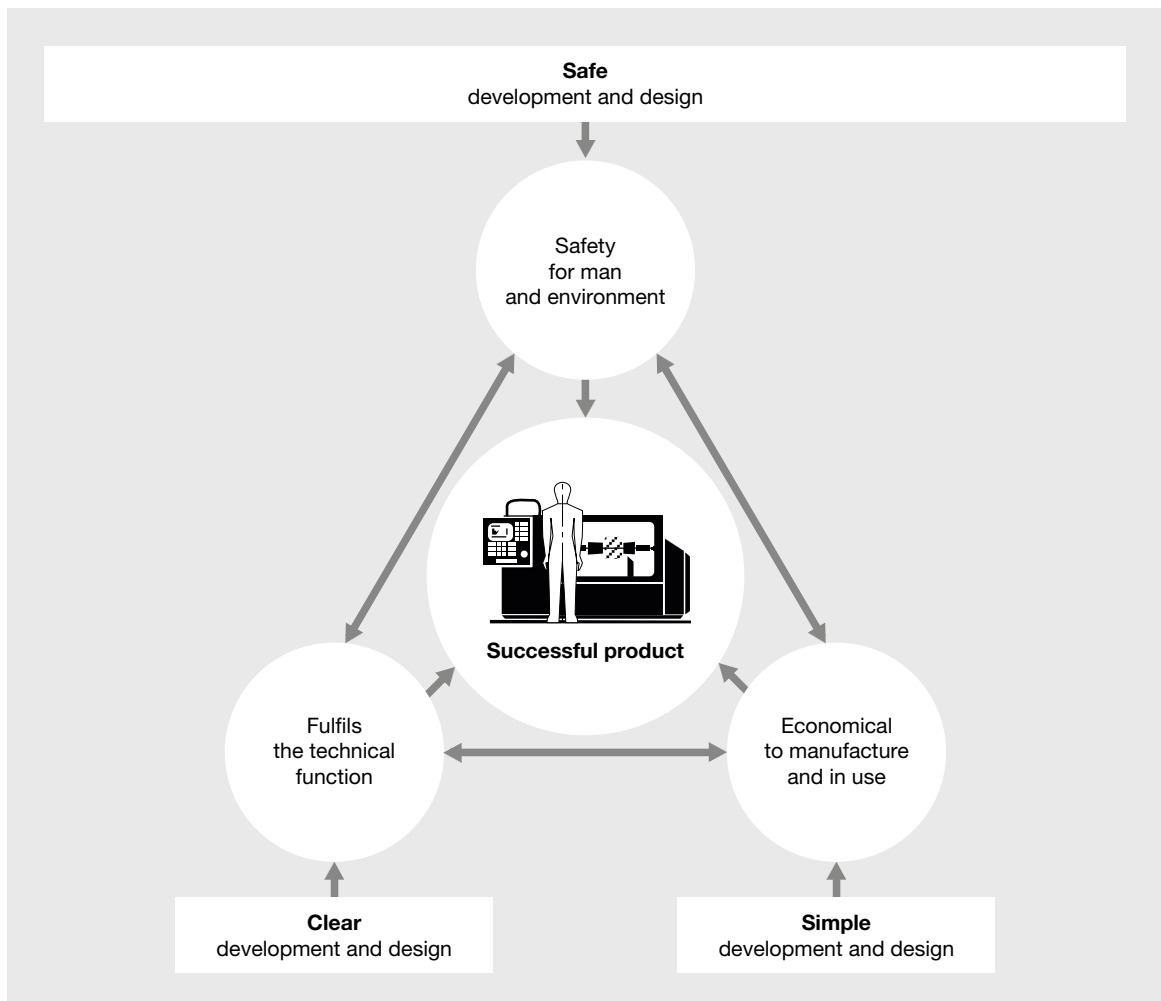

Ground rules for the design of successful products

▶ 8.2 Mechanical design

function in compliance with pre-defined boundary conditions, it is deemed to be unreliable. If a component (or even a module, machine or plant) causes an accident involving bodily harm, it is/was unsafe. The meaning of “reliable” and “safe” can be derived from the reverse implication. The logical consequence from an accident is that you can only sensibly speak of safety (or lack of safety) if all the relevant considerations of the technical systems and their design treat humans as an inextricable component of the work system, realistically, with all their deficiencies.

8.2.2 Danger, hazard, risk

Annex I of the EC Machinery Directive defines five obligatory steps as the basis for designing safety-related machinery:

1. Determine the limits of the machine including of its proper use and of reasonably foreseeable misuse
2. Systematically identify potential dangers in the design and hazardous situations resulting from these
3. Estimate the hazardous situations when working with or on the machine (risk analysis)
4. Assess the risks associated with the hazards and whether a risk reduction is necessary
5. Implement and document all the safety measures necessary to manage the risk

Regarding terminology: Viewed objectively, dangers can be regarded as an energetic or material potential that exceeds human limits and can spontaneously lead to health impairments or injuries of varying degrees of severity.

Hazards arise as soon as there is the possibility of humans coinciding with dangers in time and space, enabling an unwanted situation to arise. The effects of what happens as the hazard unfolds are subject to the relentless laws of nature.

The term risk requires a new mindset. It represents the consequences for man and the environment of hazards that occur with varying frequency.

The consequences may have various degrees of severity. The level of risk is still determined by whether technical or organisational counter-measures can or cannot be implemented. Statements of risk are calculated prognoses of potential future events, in other words, the result of human considerations and not therefore the laws of nature playing out.

For design engineers it is important to know that the causes of danger lie in the effective parameters of material, energy and information. In other words, parameters they apply during the design process and which they can use to achieve a safe condition, via the same methods employed to design functional technical systems.

The hazard from materials may not only arise from their chemical or biological properties. They can also adversely affect humans on account of their property as space-filling matter (geometry) in the earth's gravitational field: Wherever the geometric layout of the machine results in forced postures or when heavy loads have to be carried or transported by hand (strain on the spine).

Energy: Every machine needs energy to perform its technological function. Any energy used to fulfil a work function can be hazardous to humans as soon as its impact is uncontrolled and exceeds certain energy densities.





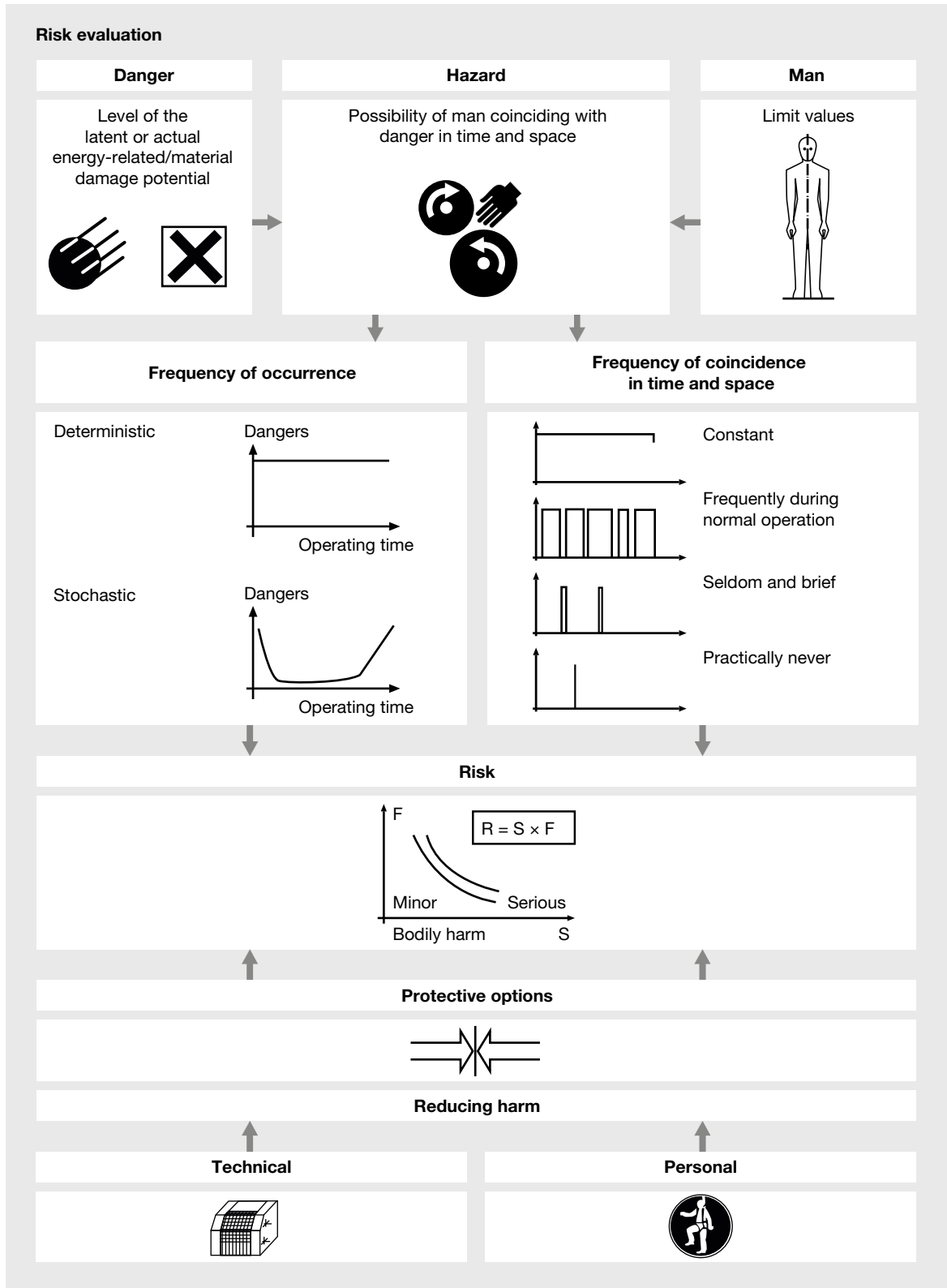





Information: A poorly designed information flow between man and machine, including the boundary conditions, can trigger behaviours which can endanger the machine user and others. In this context, the basic information parameter implies that human safety in work systems depends on the natural laws of information processing and human behaviour. As the basic parameters of material, energy and information are used in machinery, dangers can only emanate from these parameters.

► 8.2 Mechanical design



Context of risk assessment

► 8.2 Mechanical design

Effective parameter	Effect	Examples		
		No.	3	4
Material 	Spatial disposition	1		Forced postures, unreachable function elements
	Physical stresses	2		Handling of loads, high operating forces, high cycle counts
	Physical influences	3		Air temperature, draught, air humidity, high or low pressure
	Biological influences	4		Fungal cultures, bacteria in inhaled air, contaminated germ-infested air filter
	Chemical influences	5		Corrosive, poisonous, harmful, irritant substances
	Thermal influences	6		High and low ambient and contact temperatures, fire
Energy 	Explosions	7		Chemical explosions (solid substances, vapours, gases), physical explosions
	Mechanical influences	8		Places where you can fall, danger sources, danger zones, collisions, impact points
	Noise, vibration	9		Sound emissions, hand vibration, whole body vibration
	Electrical influences	10		Electrostatic charges, body through-flow, arcing
	Electromagnetic fields	11		Electromagnetic fields, magnetic fields
	Radiation	12		Electromagnetic waves, IR/UV radiation, laser, ionising radiation
Information 	Presentation of information	13		Inadequate layout of notices, control elements; incompatibility
	Light conditions	14		Luminosity, glare, luminous colour, luminance distribution
	Psychomental stress	15		Unclear operating and work instructions, software ergonomics
	Organisational failings	16		Poorly thought-out, uncoordinated sequence of operations
	Hectic pace, stress, shock	17		Incorrect operation, panic reactions, mistakes

Dangers when dealing with machinery

▶ 8.2 Mechanical design

8.2.2.1 Mechanical dangers

The essential distinguishing feature concerns the type of mechanical energy (kinetic, potential) and the question as to the basis of the energy (object or human) and which movements would precede a possible accident (kinematically based or free movements).

Hazards: Hazards occur when potential dangers and humans coincide in time and space. There are two types: stochastic (random) and deterministic (predetermined) hazards.

Deterministic hazards: These are rooted in the functional design of the machine, e.g. danger points which are a technical necessity, such as those on tools with set movements. Such hazards are latent throughout the whole of the machine's lifetime and have a consistently high level of probability. An accident at a danger point is therefore only a matter of time, unless design measures are used to counteract it. Deterministic, mechanical danger points are still the main focus for all

machine accidents because their destructive impact is underestimated, both by design engineers and by those affected. Unlike stochastic dangers, with practice, danger points are visible to the naked eye of anyone with any sort of technical interest, whether in drawings, CAD designs or on finished machinery. It is really a benefit that today's design engineers can counteract these dangers using relatively simple means.

Stochastic hazards occur with a time-based probability during a machine's lifetime. They are normally visualised with the bathtub curve, although strictly speaking this only applies to a few modules or components. It is rare for these hazards and their causes to be directly identifiable and, as is unfortunately almost always the case with spectacular accidents, they can hardly ever be reliably predicted.

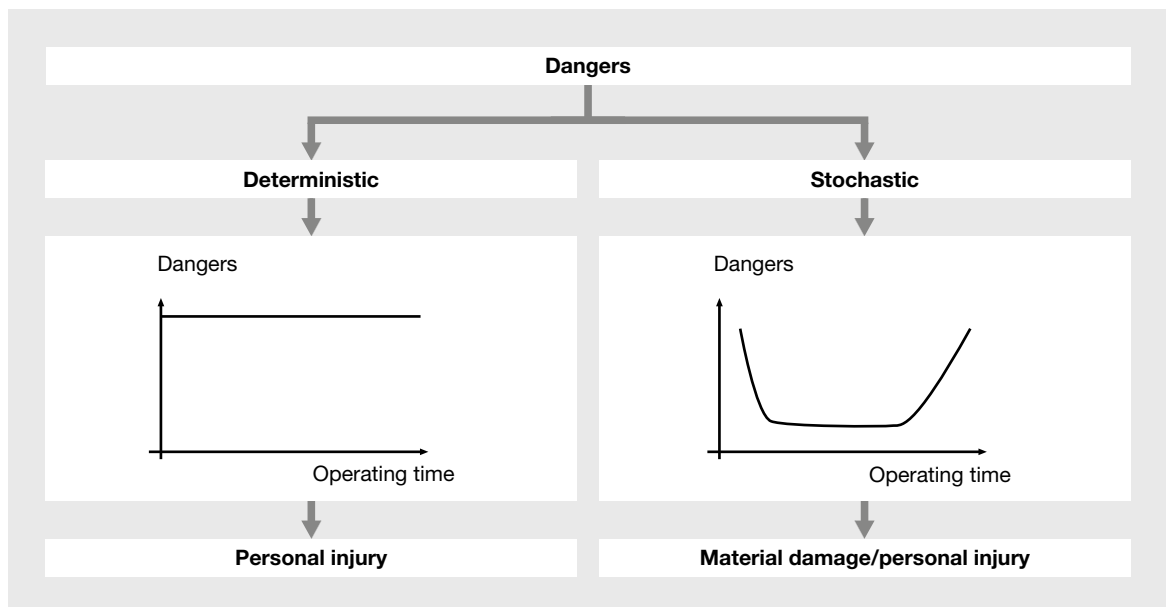

Deterministic and stochastic dangers

▶ 8.2 Mechanical design

8.2.2.2 Risk assessment

Today there are more than 80 risk assessment procedures on the market and in academia, and the number is expected to rise. However, none of them is (legally) binding. Though the Machinery Directive refers to some harmonised standards for machine safety (EN ISO 13849, EN ISO 12100, IEC 61508 or EN 62061), the implementation of these continues to be highly problematic in practice. And it's not all the fault of design engineers: With no relevant training, they are supposed to derive binding measures from multiple statements of probability for more events than are likely to occur. The following definition of technical risk is currently generally accepted:

Risk is not a law of nature, but a statement of probability (prognosis) regarding the impact of hazards on man and/or the environment under a defined set of circumstances. Risks are calculated from the frequency and severity of potential injury, damage to health or material damage, combined with the possibility or otherwise of technical, organisational or personal measures to avert or protect against the hazard. The result of the risk assessment ultimately determines the reliability requirements of the safety functions to be fulfilled by the safety-related parts of the controller. This also refers to the reliable performance of the guard function.

8.2.3 Definition and implementation of safety measures

Machine manufacturers are obliged only to supply safe products on the internal European market. For this reason, they must calculate all the hazards associated with the machine in advance and assess the resulting risks. With the knowledge gained from the risk analysis and the risk assessment, manufacturers must design their machines in such a way that cannot be harmful either to users, other persons or the environment. In other words the machines must be safe.

Many people like to use the term “safe”; after all, the feeling of safety is one of the most important basic human needs. Advertising and insurance industries, along with politicians, really understand how to address this basic need and exploit it for their own interests. In technology, “safe” is often taken to mean the fulfilment of a machine function over a fixed period. That really addresses reliability, however, so we need to be precise: In its true sense, safety is understood to be the absence of potential and real danger for man and the environment. Safety and reliability have many common features: Both describe a future machine behaviour and are therefore statements of probability.

The first commandment for safety-related design: All hazard types must be tackled within the design! The necessary design measures must counteract both unforeseeable stochastic and deterministic hazards. The different modes of operation of both hazard types also require different design methods.

Note the following when selecting the design methods:

1. Design measures should always be used to reduce existing risks to such an extent that the achieved residual risk is tolerable to the individual and society (i.e. it may occur and must then be accepted).
2. As stochastic and deterministic hazards vary substantially, it is only logical that the measures taken to counteract them must also differ.

Key:

- ▶ Stochastic: Hazards influenced by chance for which the danger potential cannot be predicted exactly, i.e. is expressed as a probability
- ▶ Deterministic: Hazards with a constant danger potential that is the same at all times

▶ 8.2 Mechanical design

Type of energy	Energy bearer	Movement	Graphic	Hazard due to
1	2	3	No. 4	5
Potential energy 	Objects 	Movement along fixed channels 	1 	Danger points on controlled moving parts: Danger is confined to a specific location.
Kinetic energy 			2 	
Potential energy 	People, parts of the body 	Free movement 	3 	Danger sources due to uncontrolled moving parts: Danger emanates from a specific location.
			4 	
Kinetic energy 	People, parts of the body 	Movement along fixed channels 	5 	Places where you can fall
			6 	Impact points
Kinetic energy 	People, parts of the body 	Movement along fixed channels 	7 	Inertia forces
			8 	

Basic mechanical dangers

▶ 8.2 Mechanical design

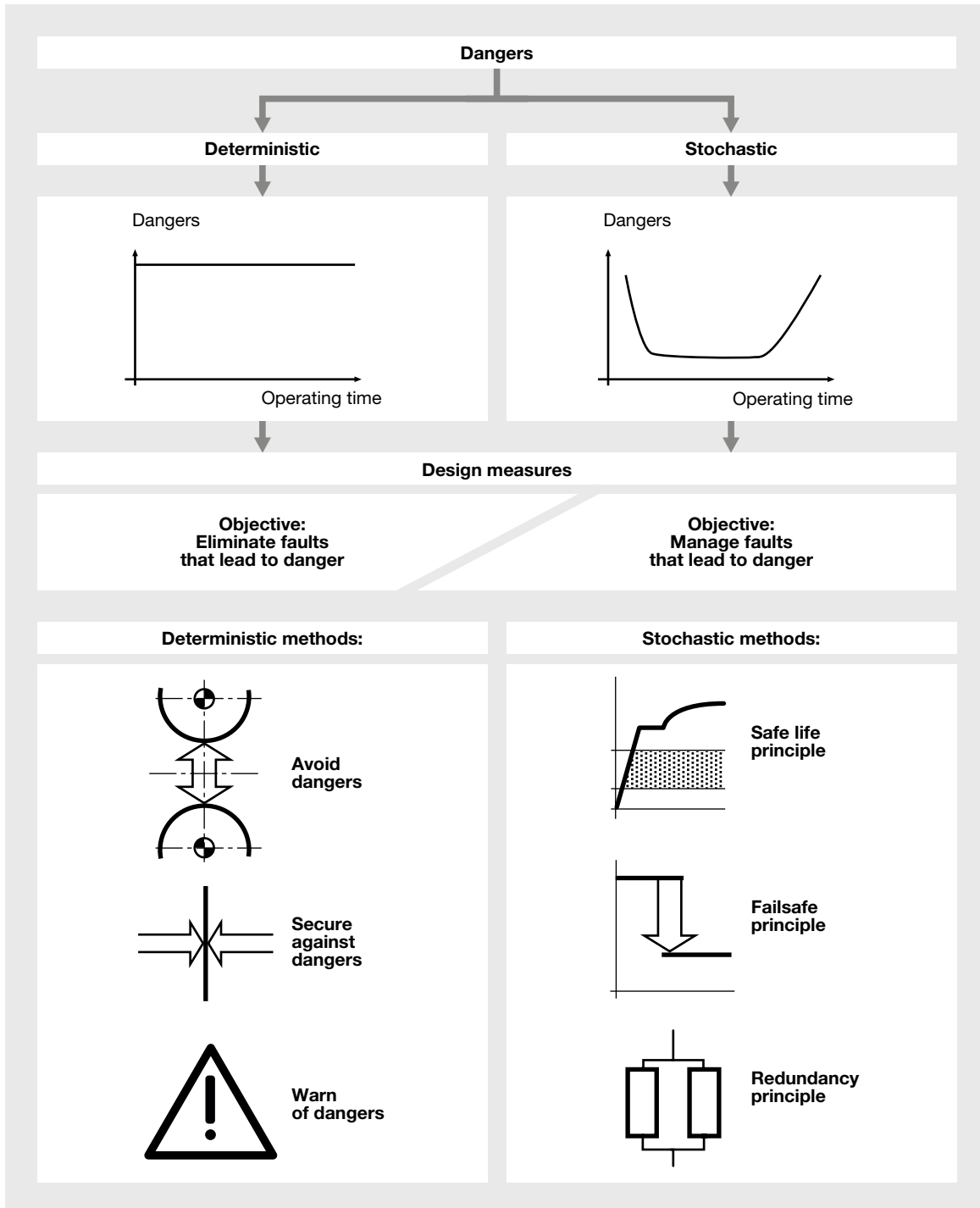

Important design measures for avoiding danger

► 8.2 Mechanical design

8.2.3.1 Design measures against stochastic hazards

Stochastic hazards can be mainly attributed to component failures or software errors. Although they affect machine reliability, they may not necessarily have an adverse effect on human safety. The aim of targeted design measures is to increase the time-based probability that machines will fulfil their intended function within an agreed operating time and remain immune to random component failures. That way they can harm neither man nor the environment. The most well known design measures are:

- ▶ Safe life principle
- ▶ Failsafe principle
- ▶ Redundancy principle

Measures relating to the **safe life principle** start from the assumption that the machine is adequately dimensioned and designed according to its function, and as such will operate as intended during its warranted lifetime: without faults, failures or danger. This design principle is particularly significant on safety devices such as rupture discs, for example. The model shown below used the extremely reliable buckling bar principle.

Application of this principle assumes that:

1. All the stresses that act on the machine are known,
2. The applied calculation methods and accepted material performance match reality,
3. No influences other than those considered in the calculation will occur during the machine's lifetime.

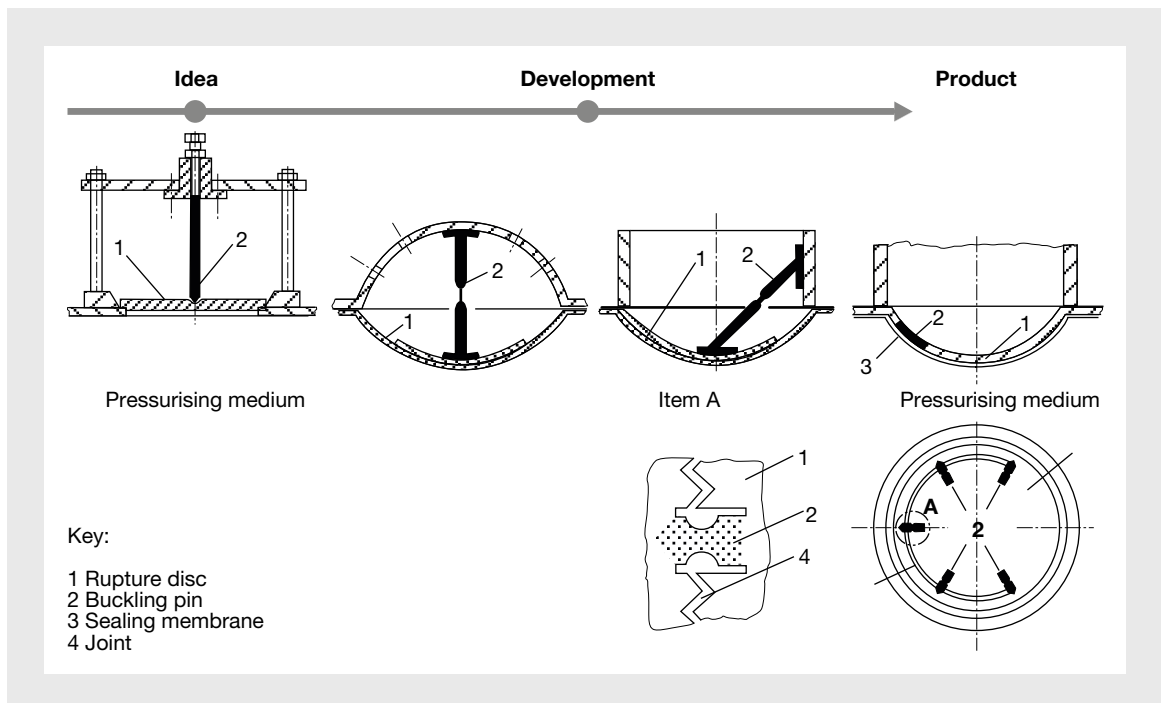

Non-fragmenting rupture disc (reverse buckling disc)

► 8.2 Mechanical design

In real life, none of these assumptions can be guaranteed. For this reason, it is advisable to take a different route. The **failsafe principle** knowingly permits errors. However, the systems are designed and constructed so that a safety-related crash does not lead into the abyss but stops at an agreed level. The systems react to faults in such a way that they “fail” to safety - although this only applies to known, identifiable and foreseeable faults. This assumes that energy for this function may be supplied within the system not just in case of emergency, but that sufficient energy is always stored in advance. This will be dissipated in the case of danger and the system transferred to a low-energy and therefore stable condition. Implementation of this principle often makes use of ever-present effects such as gravitational or frictional forces and the self-locking that can be achieved through these means.

In **redundant systems**, more components are provided to fulfil a function than are actually necessary. The assumption is as follows: If one of these components should malfunction or fail, the other will completely take over its function. The principle is to achieve the greatest possible reliability with a minimum of redundancy. As reasonable as this principle may be, it does have one important weakness: Experience shows that there are always situations, and always will be situations, in which all redundant components fail simultaneously due to a common cause failure. These situations are very difficult to predict and control through the design. Consistent but expensive diversity, particularly in terms of physical diversity, produces the best results.

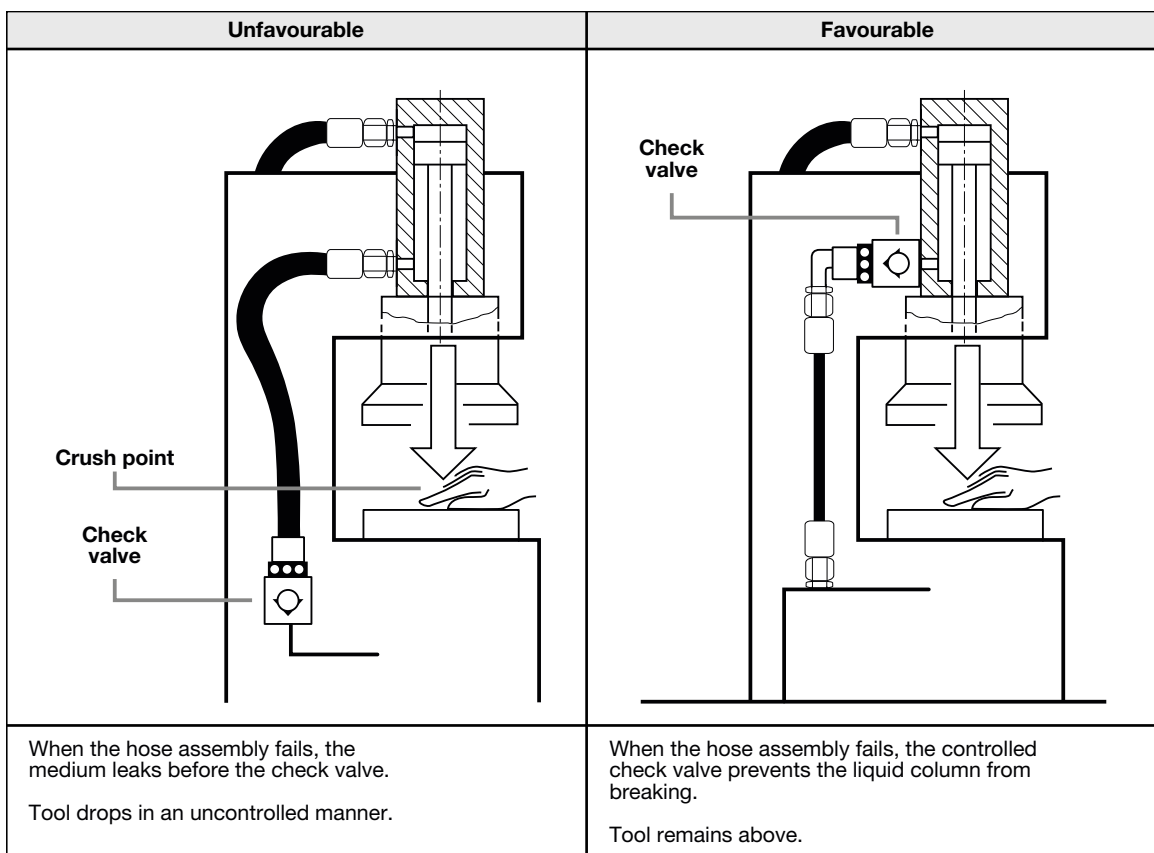

Hose assembly with check valves

► 8.2 Mechanical design

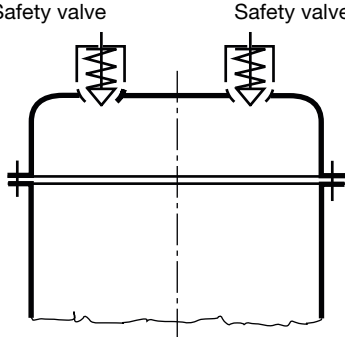
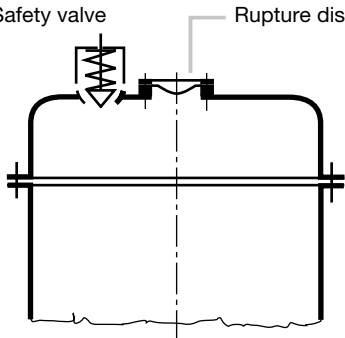
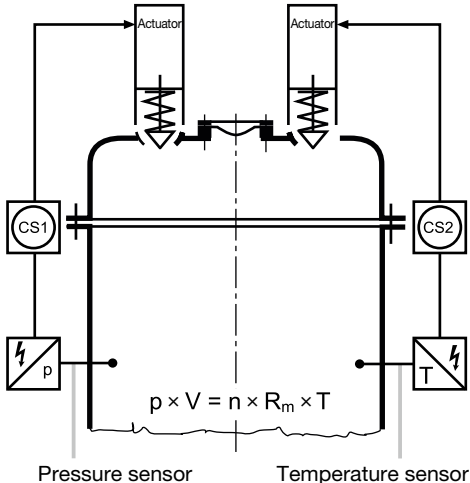
Redundancy	No.	Example	Explanation
Homogeneous	1	 <p>Safety valve Safety valve</p>	Duplication only increases safety when no systematic errors can occur, e.g. corrosion, material mix-up, which can render both safety devices ineffective simultaneously.
Diverse (components)	2	 <p>Safety valve Rupture disc</p>	Diversity in the action principle of the safety device: Switching the action principle makes it unlikely that the independent safety devices, which operate to different principles and are made by different manufacturers, would fail simultaneously.
Diverse (process variables)	3	 <p>Actuator Actuator</p> <p>CS1 CS2</p> <p>p T</p> <p>Pressure sensor Temperature sensor</p> <p>$p \times V = n \times R_m \times T$</p>	Diversity in the physical principle: Each of the diverse, controlled valves is activated by the control systems CS1/CS2, which react if a limit value on two process variables connected by a physical law (e.g. general equation of state) are exceeded.

Homogeneous and diverse redundancy

▶ 8.2 Mechanical design

8.2.3.2 Design measures against deterministic hazards

Deterministic hazards can be attributed to the functional design of the machinery, as required by technical necessity, and the employed procedures. Targeted design measures are intended to stop the possibility of latent dangers impacting on people. Three methods have been developed in the course of technical progress:

1. Direct safety technology
2. Indirect safety technology
3. Informative safety technology

In contrast to the measures taken against stochastic hazards, which are fundamentally regarded as being of equal value, the EC Machinery Directive bindingly specifies the sequence and priority in which the respective measures against deterministic hazards should be applied

1. Direct
2. Indirect
3. Informative

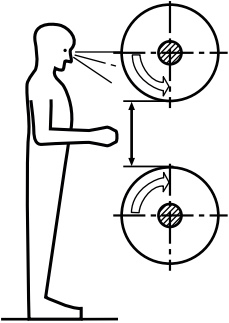
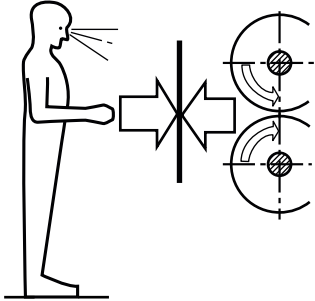
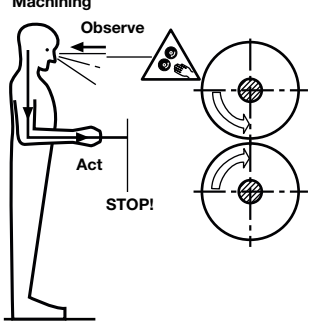
Safety technology methods			
Safety technology	Indirect	Direct	Informative
Action principle	Avoid dangers	Secure against dangers	Warn against dangers
Diagram			
EC Machinery Directive, EN ISO 12100	Eliminate or minimise dangers	Take the necessary protective measures when dangers cannot be eliminated	Instruct the user about the residual risks

Safety technology methods

▶ 8.2 Mechanical design

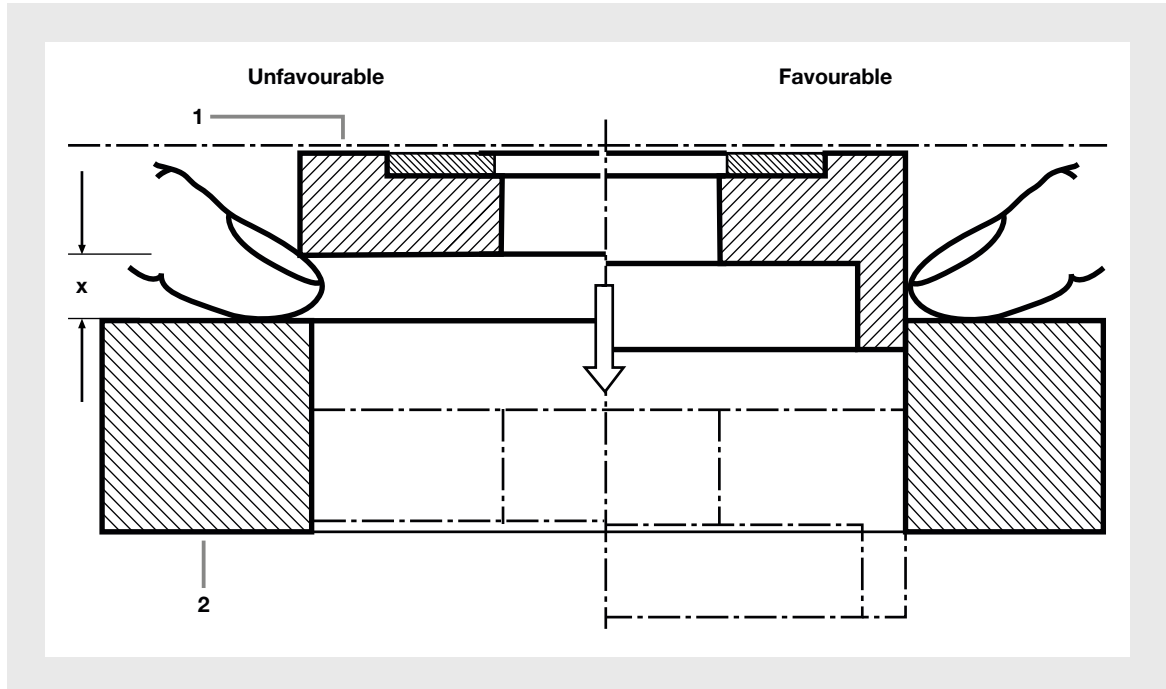

Shearing hazard avoided by design

8.2.3.2.1 Direct safety technology

Methods using direct safety technology attempt to configure components, machines and processes in such a way that they present no risk, or only a low, accepted risk to people. Geometric and energetic measures are available:

Geometric measures attempt to avoid the hazardous effect of danger points on moving machine parts by complying with standardised minimum distances to ensure that dangerous proximity does not even arise, or by making such danger points inaccessible by complying with safety distances.

Energetic measures attempt to stop the hazard's underlying energy having a harmful effect on people by:

- ▶ Limiting the effective energy
- ▶ Interrupting the flow of energy to people
- ▶ Targeted deformation of machine parts rather than the human body

The first measure attempts to limit the energies and forces that occur at a danger point, so that their impact remains below acceptable physiological values. Technically, however, such an energy level is generally only of limited use. The second measure prevents harmful impact on people by interrupting the flow of energy or forces towards the human body before the pain threshold is reached. The third measure reduces the rigidity of machine parts to such an extent that, if a danger point is accessed, machine rather than body parts are deformed.

Caution is required, however: Direct safety technology is often portrayed as a “silver bullet”, but it cannot be applied on danger points with technological functions. Safeguards against these dangers should be provided via special measures such as protective devices, for example.

▶ 8.2 Mechanical design

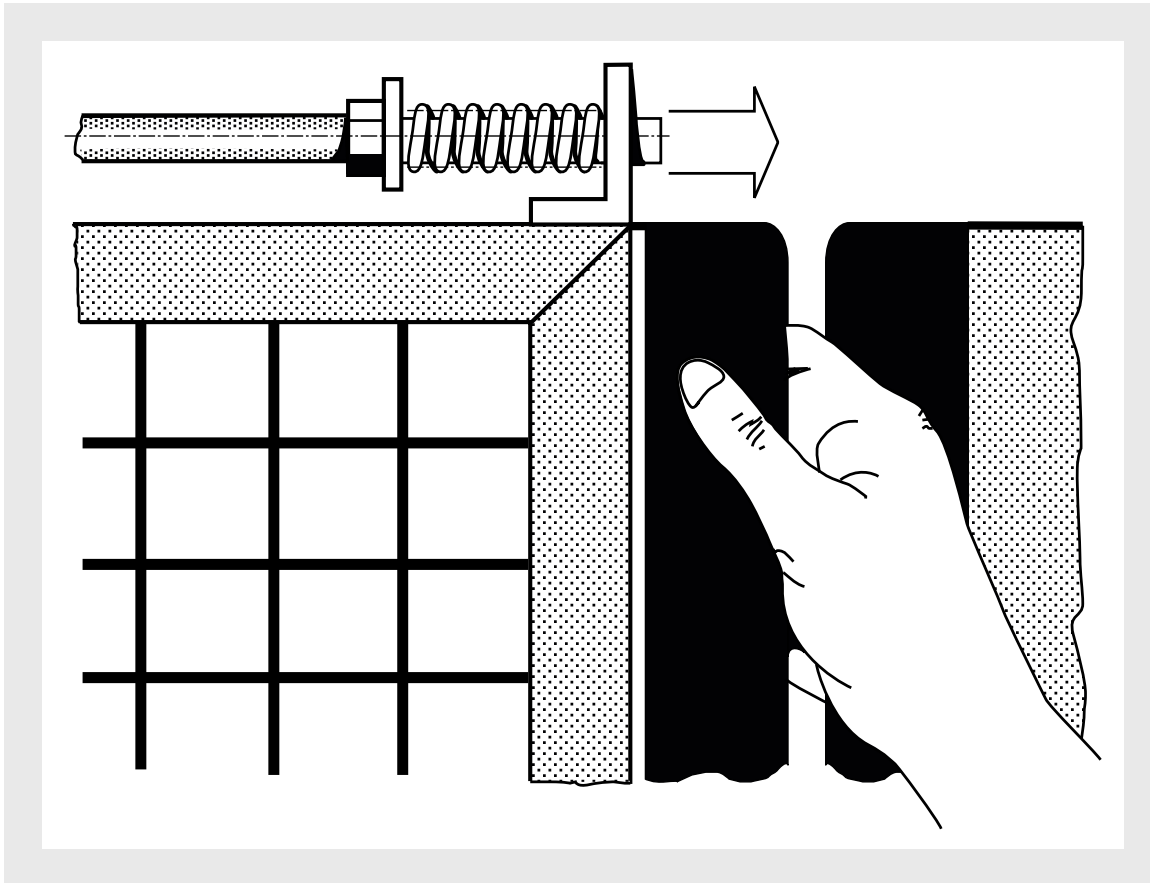

Elastic closing edges on protective devices

8.2.3.2.2 Indirect safety technology







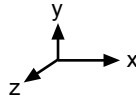

Components used in indirect safety technology safeguard against dangers that are necessary to the machine function and therefore cannot be avoided. Protective devices are arranged between operator and danger, preventing the two coinciding in time and space. Guards or protective devices are used.

Guards, e.g. enclosures or covers, form impenetrable physical barriers and as such protect against entry or access to hazardous situations. They can also prevent operators being hit by objects ejected from the protected areas.

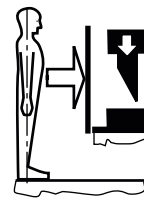
Although protective devices such as two-hand circuits or light beam devices do not prevent entry or access to hazardous situations, they do render them safe by influencing the process via the machine controller as soon as they are activated.

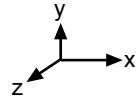
Ergonomic aspects decide on the manageability and therefore the acceptance of the protective devices. The most important ergonomic requirement is that the operators are not obstructed any more than necessary during day-to-day handling of the protective device.

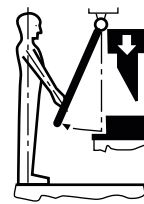
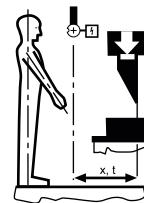
► 8.2 Mechanical design

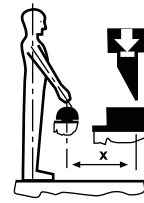
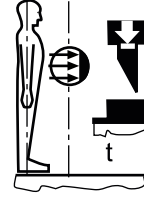
Protection against	Breaking the cause and effect relationship	Effect via	Diagram	Description	Examples	Explanation
1	2	3	No. 4	5	6	7
Danger sources 	Space 	Static physical barriers 	1 	Fixed guard	Trap covers, protection structures on earth moving machinery (ROPS, FOPS)	Safeguards hold back the uncontrolled moving parts, absorb their kinetic energy and stop them reaching people.
			2 			
Danger points 	Space and time 	Mobile physical barriers 	3 	Impeding device	Finger impeder, hand impeder	Safeguards are kinematically connected to hazardous movements. They positively keep people away from danger zones.
			4 			
	Time 	Reliable control measures 	5 	Safeguard that binds you to a location	Enabling switch, hold-to-run control device, two-hand circuits	During the hazardous movement, safeguards bind people to a safe location, from which they cannot reach the danger points. If a person should leave the safe location, the hazardous movement is stopped.
			6 			

Basic types of protective device

▶ 8.2 Mechanical design











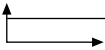

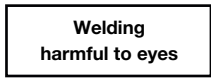
8.2.3.2.3 Informative safety technology

As the final option in combating deterministic hazards, informative safety technology attempts to ensure that at-risk personnel observe safe work practices through targeted messages and information, using methods such as: Safety signs, safety guidelines in operating manuals, internal company instruction organised by the machine user etc. The effectiveness of this method varies from country to country. It can certainly enjoy considerable success in other cultures, but it should not necessarily be relied upon in European countries. Due to different mentalities among the population, priority must be given to technical protective measures that are activated automatically and prevent or safeguard against dangers.

It would be practically impossible to build a machine with an acceptable level of risk using only one of the design measures listed here. The various methods used in these measures must instead be co-ordinated to ensure they complement each other and are effective both functionally and overall.¹⁾

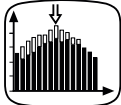
¹⁾ Source: Neudörfer A.: *Konstruieren sicherheitsgerichteter Produkte [Design of safety-related products]*, 5th edition, Heidelberg, Berlin, New York et al., Springer, 2013

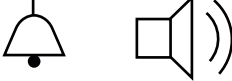
▶ 8.2 Mechanical design

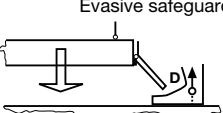
Information parameters			Example	
Channel	Process	Means		
1	2	3	No.	4
Visual 	Static 	Text	1	Operating instructions 
			2	
		Graphic symbol	3	 Stop, halting a movement Rapid stop ISO 7000
		Safety mark	4	
		Marking	5	 Colour combination: Yellow-black (permanent danger) Red-white (temporary danger)
	Dynamic 	Light signals	6	
		Active diagrams	7	 1 • Main motor 2 • Infeed table open 3 • Cover open 4 • No compressed air 5 • Film broken 6 • Magazine empty
		Process visualisation, simulation	8	
Aural 		Acoustic signals	9	
Tactile 		Moving objects	10	Evasive safeguard 

Means of informative safety technology

► 8.3 Pneumatic design

8.3.1 Relevant units

Variable	Unit	Symbol	Relationship
Lengths	Micrometre	μm	$1 \mu\text{m} = 0.001 \text{ mm}$
	Millimetre	mm	$1 \text{ mm} = 0.1 \text{ cm} = 0.01 \text{ dm} = 0.001 \text{ m}$
	Centimetre	cm	$1 \text{ cm} = 10 \text{ mm} = 10,000 \mu\text{m}$
	Decimetre	dm	$1 \text{ dm} = 10 \text{ cm} = 100 \text{ mm} = 100,000 \mu\text{m}$
	Metre	m	$1 \text{ m} = 10 \text{ dm} = 100 \text{ cm} = 1,000 \text{ mm} = 1,000,000 \mu\text{m}$
	Kilometre	km	$1 \text{ km} = 1,000 \text{ m} = 100,000 \text{ cm} = 1,000,000 \text{ mm}$
Areas	Square centimetre	cm^2	$1 \text{ cm}^2 = 100 \text{ mm}^2$
	Square decimetre	dm^2	$1 \text{ dm}^2 = 100 \text{ cm}^2 = 10,000 \text{ mm}^2$
	Square metre	m^2	$1 \text{ mm}^2 = 100 \text{ dm}^2 = 10,000 \text{ cm}^2 = 1,000,000 \text{ mm}^2$
	Are	a	$1 \text{ a} = 100 \text{ m}^2$
	Hectare	ha	$1 \text{ ha} = 100 \text{ a} = 10,000 \text{ m}^2$
	Square kilometre	km^2	$1 \text{ km}^2 = 100 \text{ ha} = 10,000 \text{ a} = 1,000,000 \text{ m}^2$
Volume	Cubic centimetre	cm^3	$1 \text{ cm}^3 = 1,000 \text{ mm}^3 = 1 \text{ ml} = 0.001 \text{ l}$
	Cubic decimetre	dm^3	$1 \text{ dm}^3 = 1,000 \text{ cm}^3 = 1,000,000 \text{ mm}^3$
	Cubic metre	m^3	$1 \text{ m}^3 = 1,000 \text{ dm}^3 = 1,000,000 \text{ cm}^3$
	Millilitre	ml	$1 \text{ ml} = 0.001 \text{ l} = 1 \text{ cm}^3$
	Litre	l	$1 \text{ l} = 1,000 \text{ ml} = 1 \text{ dm}^3$
	Hectolitre	hl	$1 \text{ hl} = 100 \text{ l} = 100 \text{ dm}^3$
Density	Gram/ cubic centimetre	$\frac{\text{g}}{\text{cm}^3}$	$1 \frac{\text{g}}{\text{cm}^3} = 1 \frac{\text{kg}}{\text{dm}^3} = 1 \frac{\text{t}}{\text{m}^3} = 1 \frac{\text{g}}{\text{ml}}$
Force/ weight force	Newton	N	$1 \text{ N} = 1 \frac{\text{kg} \times \text{m}}{\text{s}^2} = 1 \frac{\text{J}}{\text{m}}$ $1 \text{ daN} = 10 \text{ N}$
Torque	Newton metre	Nm	$1 \text{ Nm} = 1 \text{ J}$
Pressure	Pascal	Pa	$1 \text{ Pa} = 1 \text{ N/m}^2 = 0,01 \text{ mbar} = \frac{1 \text{ kg}}{\text{m} \times \text{s}^2}$
	Bar	bar	$1 \text{ bar} = 10 \frac{\text{N}}{\text{cm}^2} = 100,000 \frac{\text{N}}{\text{m}^2} = 10^5 \text{ Pa}$
	psi = $\frac{\text{pound}}{\text{inch}^2}$	Psi	$1 \text{ psi} = 0.06895 \text{ bar}$
	$\frac{\text{kp}}{\text{cm}^2}$		$1 \frac{\text{kp}}{\text{cm}^2} = 0,981 \text{ bar}$
Mass	Milligram	mg	$1 \text{ mg} = 0.001 \text{ g}$
	Gram	g	$1 \text{ g} = 1,000 \text{ mg}$
	Kilogram	kg	$1 \text{ kg} = 1,000 \text{ g} = 1,000,000 \text{ mg}$
	Tonne	t	$1 \text{ t} = 1,000 \text{ kg} = 1,000,000 \text{ g}$
	Megagram	Mg	$1 \text{ Mg} = 1 \text{ t}$

► 8.3 Pneumatic design

Variable	Unit	Symbol	Relationship
Acceleration	Metre/ square second	$\frac{m}{s^2}$	$1 \frac{m}{s^2} = 1 \frac{N}{kg}$ $1 G = 9.81 m/s^2$
Angular speed	One/second	$\frac{1}{s}$	$\omega = 2 \times \pi \times n$ n in 1/s
	Radian/second	$\frac{rad}{s}$	
Output	Watts	W	$1 W = 1 \frac{Nm}{s} = 1 \frac{J}{s} = 1 \frac{kg \times m}{s^2} \times \frac{m}{s}$
	Newton metre/ second	Nm/s	
	Joule/second	J/s	
Work/energy, heat	Watt second	Ws	$1 Ws = 1 Nm = 1 \frac{kg \times m}{s^2} \times m = 1 J$
	Newton metre	Nm	
	Joule	J	
	Kilowatt hour	kWh	$1 kWh = 1,000 Wh = 1,000 \times 3,600 Ws = 3.6 \times 10^6 Ws = 3.6 \times 10^3 kJ = 3,600 kJ = 3.6 MJ$
	Kilojoule	kJ	
Megajoule	MJ		
Mechanical stress	Newton/ square millimetre	$\frac{N}{mm^2}$	$1 \frac{N}{mm^2} = 10 \text{ bar} = 1 \text{ MPa}$
Plane angle	Second	"	$1'' = 1'/60$
	Minute	'	$1' = 60''$
	Degree	°	$1^\circ = 60' = 3600'' = \frac{\pi}{180^\circ} \text{ rad}$
	Radian	rad	$1 \text{ rad} = 1 \text{ m/m} = 57.2957^\circ$ $1 \text{ rad} = 180^\circ/\pi$
Speed	One/second	1/s	$\frac{1}{s} = s^{-1} = 60 \text{ min}^{-1}$
	One/minute	1/min	$\frac{1}{\text{min}} = \text{min}^{-1} = \frac{1}{60 \text{ s}}$

Variable	Unit	Symbol	Relationship
Density	$\frac{kg}{m^3}$	ρ , rho	$\rho = \frac{m}{V}$
Pressure loss coefficient	l	ζ , zeta δ , delta	$\zeta = \frac{2 D \times p}{\rho \times v^2}$
Friction shear stress	$\frac{N}{m^2}$	τ , tau	$\tau = \frac{F}{A}$
Static viscosity	$Pa \times s = \frac{kg}{m \times s} = \frac{N \times s}{m}$	η , eta	$\eta = \nu \times \rho$
Dynamic viscosity	$\frac{m^2}{s}$	ν , nu	$\nu = \frac{\eta}{\rho}$
Flow rate	l/min	Q	$Q = k_v \sqrt{\frac{\Delta p}{\rho}}$
Normal nominal flow rate	l/min	q_{nN}	With $T = 293.15 \text{ K} (20^\circ\text{C})$, $p_1 = 6 \text{ bar}$, $p_2 = 5 \text{ bar}$, $\rho_{\text{air}} = 1.292 \text{ kg/m}^3$

▶ 8.3 Pneumatic design

8.3.2 Introduction

Pneumatics is one of the drive technologies in engineering, alongside electrics and hydraulics. To ensure that a machine can be operated safely, it is not enough to identify hazards and then pass this information to a controller or safety components. The drives must be brought to a safe condition; only then is the machine safe.

8.3.3 Well-tried principles and protective measures

Safe pneumatics can be divided into two basic fields: Firstly, the basic and well-tried principles, as described in Annex B of DIN EN ISO 13 849-2, and secondly, the protective measures relevant for pneumatic drives. These include control technology solutions that move a cylinder in accordance with a desired behaviour.

8.3.3.1 Basic and well-tried principles

First let's look at some basic and well-tried principles of pneumatics. These include good compressed air treatment: Compressed air must be filtered and must be free of water and compressor oil. Poorly treated compressed air will cause elements to malfunction. Valves no longer switch and become stuck; cylinders may move unintentionally due to leakages. And there's the recurring question on whether or not to lubricate compressed air. The maxim here is: Lubricate once, lubricate forever. However, today's pneumatic components have lifetime lubrication and no longer need to be lubricated. If new components are built into old machines on which the compressed air is lubricated, the new parts will also be lubricated. In this case, select a lubricant that is valve-compatible. Only use a small amount of lubricant, for "overlubrication" will also lead to malfunctions.

8.3.3.2 Selection and dimension

The pneumatic components should be selected and dimensioned to withstand the expected demands. Environmental conditions such as temperature, oils, acids, alkaline solutions and cleaning agents should be noted. A good safety-related circuit is worthless if aggressive cleaning agents soften the pneumatic hose. Pneumatic cylinders are usually calculated so that they supply the force required in the machine. However, the calculation should also take account of kinetic energy. If a cylinder moves too quickly – applications frequently require high cycle counts – the energy with which a pneumatic cylinder travels to the end position will be correspondingly high. This will damage the cylinder in the long term.

▶ 8.3 Pneumatic design

8.3.3.3 Pressure limitation

Another basic principle is pressure limitation. A pressure relief valve is located on the air chamber behind the compressor and protects the air chamber from explosion. The machine has an integrated service unit, which regulates the operating pressure. If the setting for the operating pressure is turned up, the forces within the plant will increase, which can lead to an overload. Consequently, the machine operator should not be able to change the operating pressure without authorisation. It makes sense, therefore, to have a pressure relief valve in the service unit, protecting the machine from a dangerous failure of the pressure regulator. If there were any defect, the machine would face the full mains pressure. For this reason, further pressure limitation measures are required, which will affect the dimensioning of the cylinder. Where pneumatic cylinders are installed vertically, excess pressure arises on the cylinder due to the moving mass, the operating pressure and the surface difference. If this cylinder is then to be stopped pneumatically, e.g. by closing off the compressed air, pressure peaks of well over 30 bar are possible. In turn, this pressure will overload all the pneumatic components used in this part of the circuit.

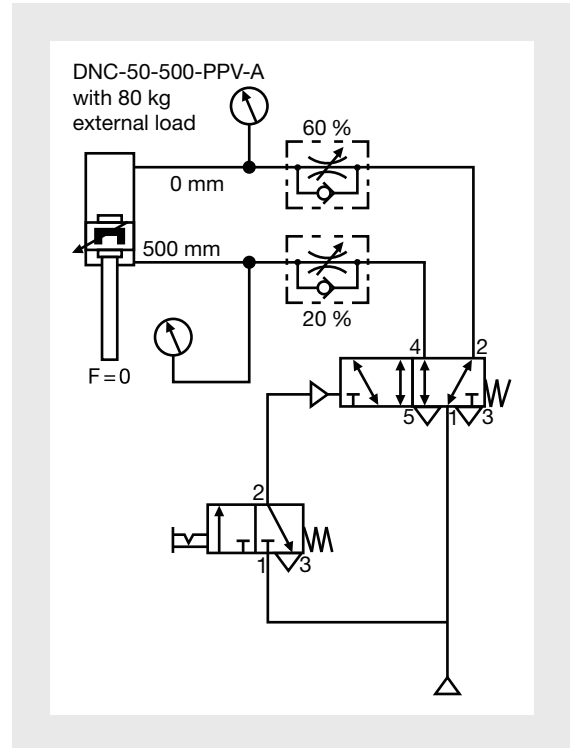

Circuit diagram, pressure values (source: Festo)

Component description	Identifier	State variable	0 1 2 3 4 5 6 7 8 9 10
Cylinder, double-action	DNC-50-500-PPV-A	Travel mm	
Pressure gauge	Pressure up	Pressure bar	
Pressure gauge	Pressure down	Pressure bar	

Pressure values (source: Festo)

► 8.3 Pneumatic design

These pressure peaks can be reduced by installing a pressure regulator between the operating valve and the upper cylinder connection. In this case, the cylinder's downward movement is supported not with the normal operating pressure but with a pressure reduced to 2 bar. If the cylinder is subjected to very high pressure, no pressure is needed for the downward movement. In this case, a silencer is screwed into the upper cylinder connection. The cylinder can then be controlled with a 3/2 directional valve because the pressure is only needed for the upward movement.

8.3.3.4 Positioning of safeguards

Application in conjunction with a light beam device or two-hand circuit provides another reason for ensuring that the design of a pneumatic circuit is thorough and correct. In accordance with DIN EN ISO 13855 "Positioning of safeguards with respect to the approach speeds of parts of the human body", the stopping performance of a hazardous drive must be measured and the measurement used to determine the distance of the light beam device or two-hand circuit. The speed of a pneumatic cylinder depends not only on the operating pressure, mass and mounting position, but above all on the screw joints, hoses and valves that are used, along with their flow rates. If the latter is not calculated, the assembler will determine the machine's cycle counts and thereby the stopping performance for a light beam device, based on a greater or lesser degree of knowledge. If an operator then changes the hoses and screw joints, enabling a higher flow rate, he will be changing the stopping performance at the same time. The distance of the light beam device may no longer be sufficient for this drive; the risk of a hazardous incident would increase significantly. It is advisable, therefore, to make all the drive calculations in full and to include the values for hoses and screw joints in the circuit diagram. An indication that the information is "safety-related" also makes sense. A photograph during the acceptance test, showing exactly this layout, would also be a helpful guide in the event of any legal dispute.

8.3.3.5 Basic principle of mechanical springs or air springs

The mechanically well-tryed spring is another basic principle of safety technology, in mechanics as well as pneumatics and hydraulics. On valves with a mechanical spring, the valve's switching position is clearly defined if the control signal or even the compressed air supply is switched off. This is not the case on pulse valves (bistable valves with two coils). When selecting monostable valves it is worth paying particular attention to the return mode, for not only are there mechanical spring return valves but also air spring return valves. The diagram below shows two monostable valves. The upper valve has a mechanical spring, the lower valve has an air spring. The return mode is shown on the right-hand side of the valve. These are 5/2 directional valves with pilot control, manual override and electrical activation.

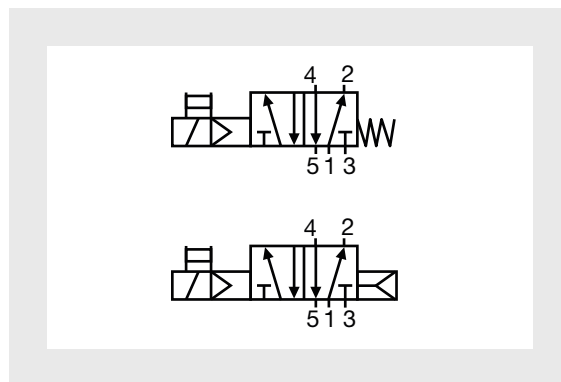

Monostable valves with mechanical / air spring
(source: Festo)

▶ 8.3 Pneumatic design

However, air-spring valves can only be reset if sufficient pressure is available for the air spring. The compressed air supply to the air springs can come from pressure port 1 or from a separate control air connection. Ultimately, this depends on the valve series. Specialists must clarify whether air-spring valves can be used in safety-related circuits, and under what conditions. Very close attention must therefore be paid to the design of the valve in pneumatic circuit diagrams.

Further safety principles in pneumatics concern the reduction of force and speed. These are mainly applied in set-up mode. Force is reduced by lowering the operating pressure for the cylinder. In pneumatics, speed is generated via the intensity of the flow rate. In both cases, the supply of pressure to the operating valve is simply switched. The risk assessment will determine whether this switchover needs to be single or dual channel.

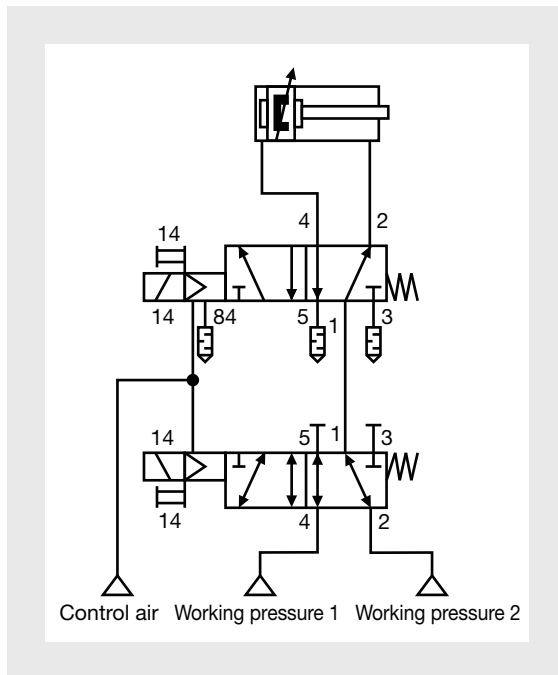

Reduced force (source: Festo)

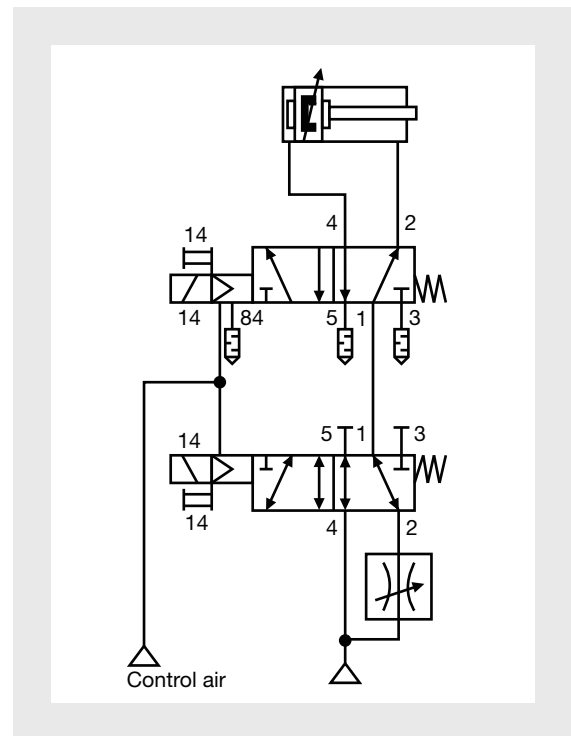

Reduced speed (source: Festo)

The circuit diagram for reduced speed only represents the principle. As the hoses and screw connections between the operating valve and the cylinder also affect the speed, reduced speed is generally achieved through valves that sit directly on the cylinder.

▶ 8.3 Pneumatic design

8.3.4 Circuit-based solutions

Having looked at some examples for basic and well-tried principles in pneumatics, let's look now at the actual protective measures. Protective measures for safety-related pneumatics describe circuit-based solutions. These include:

- ▶ Protection against unexpected start-up
- ▶ Ventilation and venting
- ▶ Braking the movement
- ▶ Blocking the movement
- ▶ Reversing the movement
- ▶ Free movement option
- ▶ Balancing forces on the drive

Protection against unexpected start-up

In the first instance, a manual start-up valve on the service unit provides effective protection against unexpected start-up. With this manual valve, the maintenance engineer can vent the machine, using a padlock to protect against a restart. The next sensible measure is an electrical start-up valve, which can be activated via a higher level control system. This measure also includes a pressure sensor, which monitors the operating pressure. The control system detects any drop in pressure and consequently switches off all the outputs plus the soft start valve. As soon as the corresponding operating pressure has returned, the controller switches the compressed air back on and ventilates the machine and its drives.

The proper selection of operating valves is another effective protective measure. Valves with a separate control air supply cannot be switched without control air. As a result, valves would be prevented from switching in the event of an electrical fault. What's more, if the installed operating valves are closed in their rest position, there will be no cylinder movement when the machine is ventilated, as the compressed air is still unable to reach the cylinder. If the installed operating valves allow air to reach the cylinder when the compressed air is switched on, a slow build-up of pressure is generally desirable. A soft start valve can be used in this case. This valve will initially ventilate the machine slowly via a throttle point. The valve will not open fully until an operating pressure of 3 bar is present, for example. Only at this point will the entire operating pressure be available at full flow rate. In the initial ventilation phase, this valve can thus be used to perform slow and controlled cylinder movements. Should a hose be installed incorrectly, there would immediately be an audible hissing sound, but the hose would not thrash about forcefully, as it would if full pressure were applied.

▶ 8.3 Pneumatic design

8.3.4.1 Venting

Venting is frequently used as a protective measure. It is employed when the cylinders are de-pressurised and do not represent a danger. However, the respective mounting position and the mass at the cylinders must be taken into account. The concept of this measure is similar to that of removing power in the electrical field: The electrical voltage is simply switched off to avoid hazards from contact with electrical cables. The principle is exactly the same in the pneumatic field, for without power/compressed air, there's no danger. However, in safety technology it is always necessary to examine the mechanics which will ultimately have to perform the movements. If a vertically-installed cylinder is vented, the cylinder piston will obey inertia and move downwards. Additional protective measures must be considered for this exact scenario. In industry, however,

the practice of ventilating and venting is coming under increasingly critical scrutiny for quite different reasons: The procedure costs a lot of time and therefore money; productivity falls.

The fact that safety is the first priority is undisputed. A machine can certainly be ventilated and vented at performance level PL = "e". The soft start and exhaust valve MS6-SV is a safety component in accordance with the MD 2006/42 EC and meets performance level "e". It is an intrinsically safe, redundant, mechatronic system in accordance with the requirements of DIN EN ISO 13849-1. The pneumatic safety-related objective, i.e. safe venting, is guaranteed even if there is a fault in the valve (e.g. due to wear, contamination).

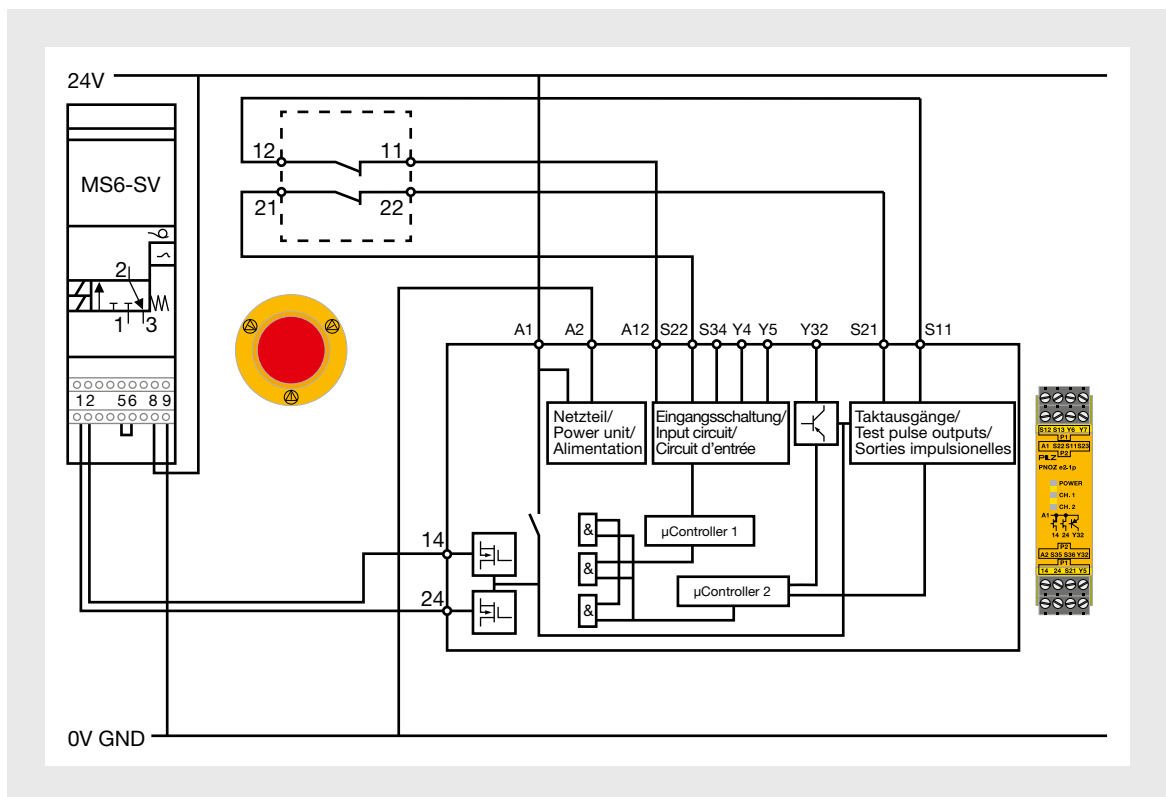

Schematic, safe ventilation and venting (source: Festo)

► 8.3 Pneumatic design

The schematic on page 8-28 shows a circuit with a dual-channel design for safe ventilation and venting. Two enable signals are sent from the electronic safety relay to pins 1 and 2 on the MS6-SV. An additional electronic safety relay would draw attention to any shorts between the two devices. As a result, performance level “e” can be achieved. The circuit diagram does not show the potential feedback from MS6-SV to the PNOZ. A volt-free contact, which is incorporated into the feedback loop, is available for this purpose. This enables the PNOZ to detect whether the MS6-SV is ready for operation.



Festo MS6-SV (source: Festo)

Single-channel ventilation and venting is also possible, of course. Electropneumatic valves in the service unit fulfil this purpose, receiving their commands from the higher level controller or from a single-channel safety circuit. Venting can also be implemented via the operating valve 1V1.

8.3.4.2 Normal operation

In normal operation, one of the two valve coils 1M1 or 1M2 is always under voltage. The valve is thereby switched. So the cylinder piston is either in one end position or moves from one end position to the other. The cylinder is vented when the operating valve is in its middle setting. This is the case when both coils are de-energised. The venting process on the operating valve is faster than venting via the service unit because the route for the compressed air is shorter and the pressure volume to be vented is lower. If venting is performed via the service unit, several cylinders will be vented and at the same time the pressure volume will be higher. There is another advantage to venting via the operating valve: Additional protective measures can easily be implemented in parallel on other cylinders, such as “reversing” for example.

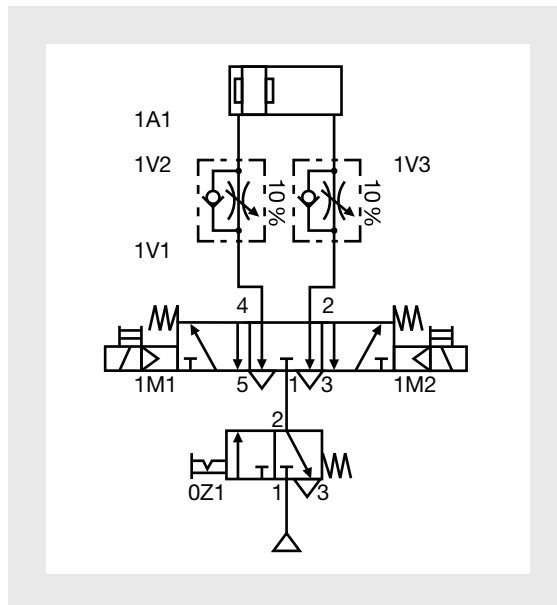

Venting with 5/3 directional valve (source: Festo)

► 8.3 Pneumatic design

8.3.4.3 Reversing

“Reversing” as a protective measure is the right choice when the movement of the cylinder piston is dangerous in only one direction.

The monostable 5/2 directional valve, as shown in the diagram with 1V1, needs an electrical control signal at the coil 1M1 in order to switch the valve. The cylinder's piston rod extends in sequence. If the coil is switched off, the control force on the left side of the valve will be missing. The mechanical spring on the right side can switch the valve back on; the piston rod continues to retract. In the normal machine cycle, the control system switches the valve coil on and off. A safety relay connected between the control system and the valve coil can also switch off the coil. In this case, it would be irrelevant whether the output on the control system (a non-safety-related PLC for example) is still switched on. Even if the electrical supply voltage should fail, the valve

would be switched back to its home position.

The piston rod cannot reverse until compressed air is returned. The emergency stop function therefore needs a stop category 1 for reversing. The compressed air will not be switched off until the cylinder has reached its safe end position. A stop category 0 switches off the compressed air supply immediately and cannot be used in this case because reversing would no longer be possible.

All pneumatic circuit diagrams must allow for a total failure of the compressed air supply. The electronic control system detects the failure of the compressed air: To ensure that the piston rod has sufficient air available to guarantee that the piston rod can reverse, a stored volume is arranged upstream of the operating valve. A check valve is connected upstream of the stored volume to ensure that the stored air cannot discharge in the direction of the compressed air supply. As a result, the compressed air always flows in the direction of the cylinder.

8.3.4.4 Failure mode

When considering the failure mode of the operating valve, the following possibilities are conceivable:

- The valve does not switch, so the piston rod does not move either. There is no danger. There may be various causes. It may be that voltage is not reaching the valve coil, the valve may be defective. Sometimes the armature in the coil or the piston in the valve may stick.
- A different type of error occurs if the valve does not switch back. In this case, the piston rod continues to extend or remains extended. On the electrical side, a short may be the reason, or possibly the valve piston is hanging up. In any case, this is a dangerous failure.

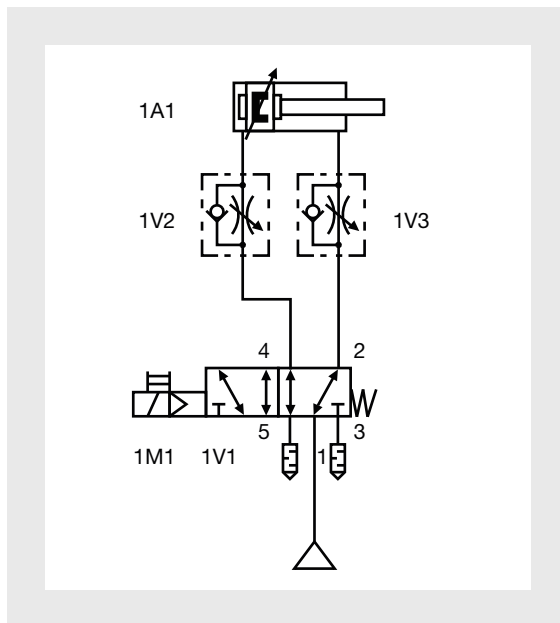

Single-channel reversing (source: Festo)

► 8.3 Pneumatic design

► Another error source lies exclusively within the valve: The valve piston remains stuck in an intermediate position. To be able to describe this fault more specifically, you need to be familiar with the internal design of the valve. The question is, when the valve piston is in the intermediate position, are all the valve's connections blocked off or interlinked? If all the connections are blocked off, compressed air can no longer flow through the valve. If the cylinder piston is extended, compressed air would no longer flow in, but neither would any air flow out of the cylinder. This would represent a dangerous failure of the valve. If all the valve's connections are interlinked, the cylinder would possibly not be completely de-pressurised, but its force would be substantially reduced. Ultimately, the cylinder's mounting position and the mass to be moved would need to be considered in order to estimate the danger.

It is clear that single-channel systems will fail in the event of a dangerous failure of one component in the safety chain. As a result, they can only be used when the risk is low. For greater risks, dual-channel systems should always be selected.

On a dual-channel system, both operating valves 1V1 and 1V2 must be switched to enable the piston rod to extend. If one valve fails to switch, the piston rod will not extend. If both valves have switched and one valve switches off, because the cable to the coil is broken for example, the piston rod will retract, even if the other valve is still switched. If one of the two valves becomes stuck in the switched position but the other valve can still be switched, the piston rod will either extend or retract, depending on how the functioning valve is switched. This is called single fault tolerance, as a dangerous failure does not lead to the loss of the safety function.

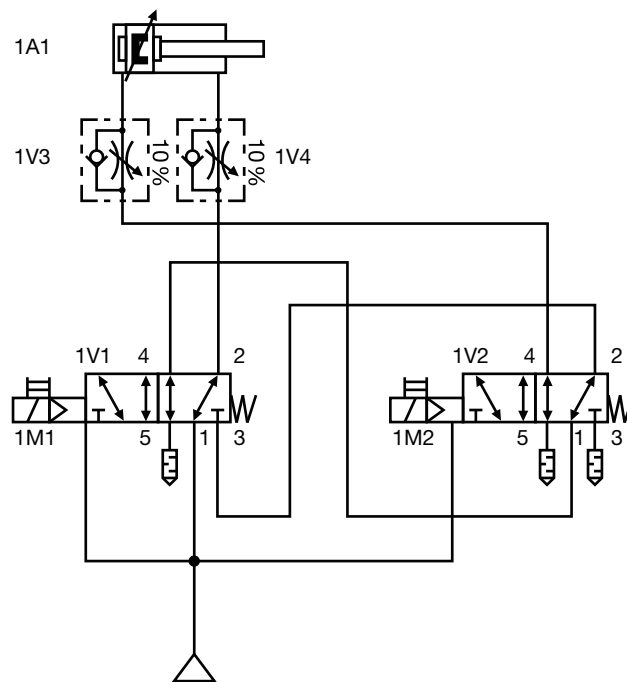

Dual-channel reversing (source: Festo)

► 8.3 Pneumatic design

How do you detect a dangerous failure on a valve? Valves with integrated switching position sensing offer one possibility. These valves have an integrated sensor in the body of the valve, which senses the switching position of the valve piston. A diagnostic coverage of 99 % can be applied when calculating the performance level for this valve. Pressure sensors on either of the two valve outputs are another possibility. When a signal changes at the valve coil, the signal at the sensor must change within a very short time, in which case the valve, sensor and wiring are all in order. This applies for the pressure sensor as well as the sensor integrated within the valve.

A third possibility is provided by valve diagnostics, which make use of the sensors that are normally installed on the cylinder to sense the cylinder's switching position. This demands some skill from the programmer, however. The cylinder's piston rod is in the rear end position; the sensor registers this position. Initially, only one operating valve is switched, so the piston rod is not yet permitted

to leave the end position. The piston rod may only leave the end position once the second valve is switched. If the piston rod were to extend even as the first valve was switched, this would indicate that the second valve was already switched. A fault would therefore be present. The other operating valve must not be switched until the next cycle; this is the only way to detect a dangerous failure of the second valve. It is important to check all sensors for a signal change, for only a signal change confirms that the sensor and wiring are operating correctly. The example below illustrates the interaction between pneumatics and electrical engineering.

A standard PLC controls the normal machine cycle. As the cylinder is categorised as a dangerous drive, a risk analysis resulted in a dual-channel design for controlling the cylinder. If a dual-channel safety switch acts upon a dual-channel safety relay, the safety relay will switch off the coils on both valves 1V1 and 1V2 if the safety switch is operated. The PLC needs a signal so that it can also switch off

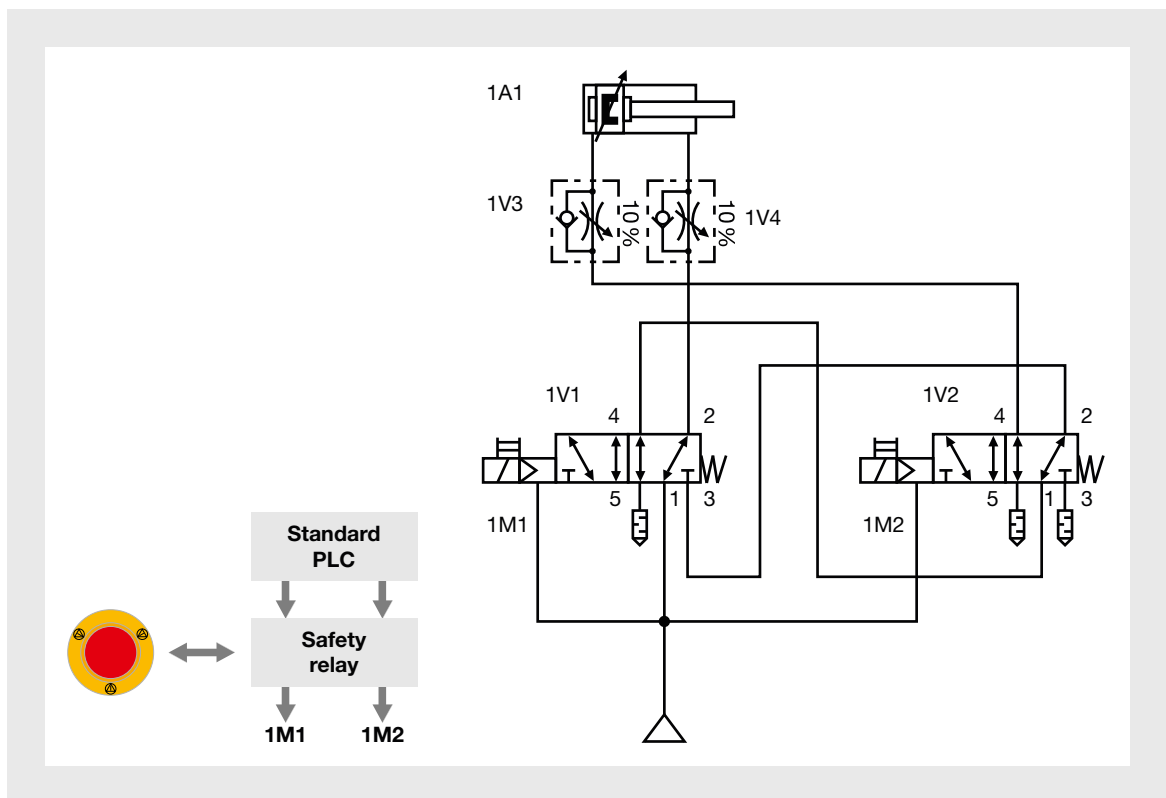

Interaction between electrical engineering and pneumatics (source: Festo)

► 8.3 Pneumatic design

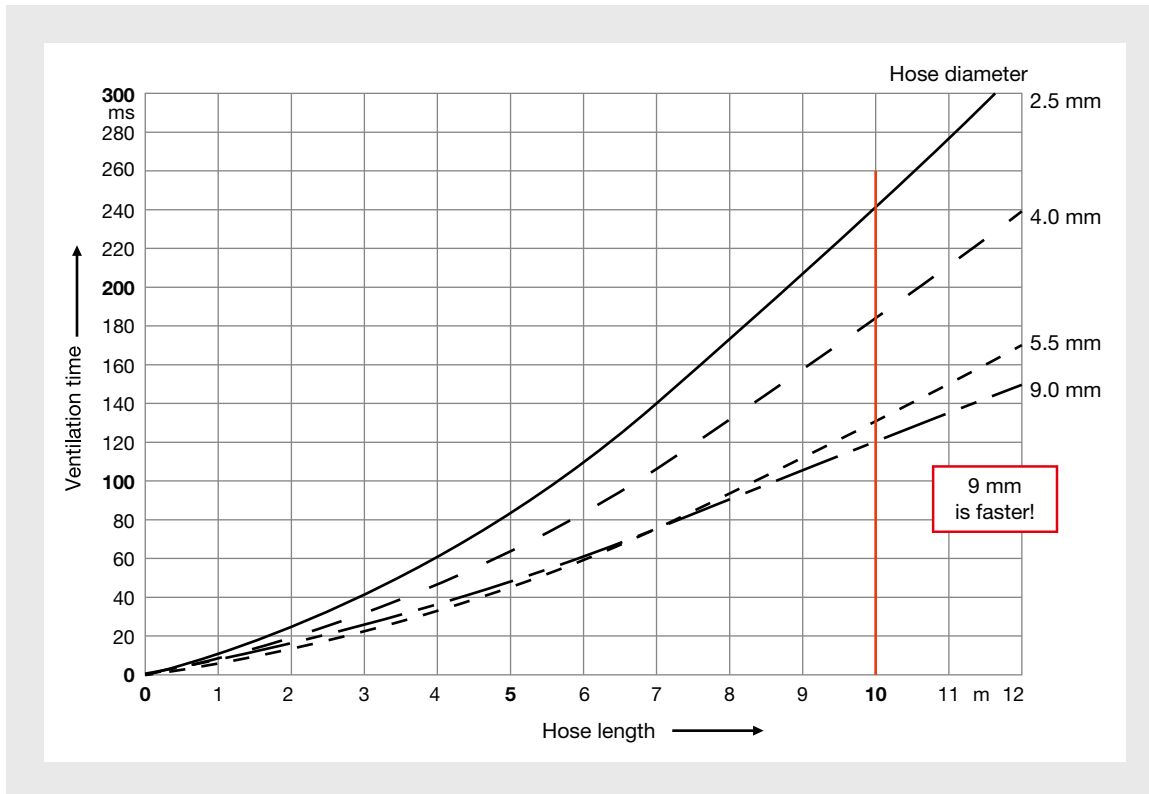

Ventilation time based on hose length and diameter at 6 bar (600 kPa) (source: Festo)

The ventilation time rises as the length of the hose increases; the increase is more pronounced on thin hoses than on thick ones. The behaviour when venting is the same, so the brake's reaction time depends on the hose. The brake is activated later with a long, thin hose than with a short, fat hose. For this reason, it is always beneficial to locate the shift valve directly on the brake. The brake closes when the pressure drops below approx. 3.5 bar. So when the compressed air drops below the set operating pressure, the brake reacts more quickly. However, care needs to be taken if the machine operator can adjust the operating pressure on the machine himself. If the operating pressure is increased, the venting time will also be extended. The brake will react later, the stopping performance will be longer. Brakes and clamping cartridges are zero fault tolerant, in other words, they can fail. Just like on a car, a brake is subject to constant wear. For this reason, it must be tested at appropriate intervals. For further details on the design and

testing of the brake please refer to the operating manual or consult the manufacturer. The influence of hose length and diameter is also important for the cylinder speed. The shorter and thicker the hose, the faster the cylinder, the higher the kinetic energy and the longer the stopping distance. This is important in connection with light beam devices etc. and the required distance from the danger point.

8.3.6 Circuit diagram and operating manual

To conclude, some thoughts on pneumatic circuit diagrams: Annex 7 of the Machinery Directive calls for an operating manual. This operating manual should provide all persons working on the machine with all the information necessary to perform their work safely. For the maintenance engineer, this means having circuit diagrams available that are complete and correct and apply for the machine. They must be able to locate the components they

▶ 8.3 Pneumatic design

see on the circuit diagram on the machine, otherwise it is impossible to work safely. Connection designations should be included in the circuit diagram; the hose connections should be made accordingly. Components should be identified and the connections named. These markings should be identifiable over the whole of the machine's service life. It makes sense for safety-related components to be identified on the circuit diagrams. As such, the maintenance engineer will recognise the special significance of these components. The correct connection designations should be stated alongside the component designations. If hoses are connected incorrectly because the connection designations are incorrect, the piston rod will suddenly extend rather than retract when the valve is activated electrically.

Under what conditions is a circuit diagram drawn and viewed? All drives and valves are shown in their home position; compressed air is present, even if the start-up valve on the service unit is shown in the off position. The home position is the position of the drives before automatic mode is started and is different from the position of the machine when de-pressurised. The piston rod is extended where cylinders are installed vertically, while the piston rod is retracted to the home position on this cylinder. Before starting automatic mode, the control engineer must first bring the drives to the home position. With the exception of mechanical directly actuated limit switches, all valves are shown in the non-actuated condition. On monostable valves and middle-setting valves, this switch setting is defined by the mechanical spring.

The circuit diagram display starts at the bottom left with the service unit or pressure source and continues towards the top right. However, when drafting or planning the circuit diagram, you should start at the top with the drives and only draw the service unit at the end. Before the design engineer starts to think about the control valves for the cylinders, he needs to be clear about the mounting position, the behaviour in the event of a power failure and subsequent restoration (pneumatics and electrics), the necessary protective measures, plus the control and stop category. The frequently fixed

allocation of 5/2 directional valves to double-acting cylinders generally leads to a vain attempt to provide individual cylinders with reasonable, effective and above all low-priced safety circuits.

Only when all the requirements of the cylinder have been defined can thoughts turn to the service unit. The cylinders may require different operating pressures, in which case several pressure regulators will need to be used. In the event of an emergency stop, only one part of the compressed air should switch off, while in another part of the machine, full pressure should still be available. Valve terminals require a separate control air supply, for which the service unit must offer an appropriate solution. Once these aspects have been considered, a service unit can often look quite different to the one that was originally planned. This is a disadvantage if the service unit has already been ordered at an early stage: The additional parts that are needed will have to be selected, ordered and installed and the necessary modifications will be complex, costing even more time and money. Information regarding hose colours and hose cross sections, screw joints and hose numbers help to provide clarity during assembly and when troubleshooting. Clarity is always a plus for safety and speed; DIN ISO 1219, DIN ISO 5599 and DIN EN 81346-1 are standards dealing with the generation of circuit diagrams and graphic symbols.

In pneumatics, is safety technology more difficult than electrical technology? Essentially no. The basic principles and concepts are the same or similar. Compressed air as a medium is different; to many people it's new and unfamiliar. As with electrical drives, mechanics must also be considered in pneumatics. An electric motor does not operate through its shaft alone; extensive mechanics generally follow to a greater or lesser extent as is the case with pneumatics. The information in this chapter, with its examples, ideas and suggestions, is simply an initial introduction to the subject of "safety and pneumatic design" and is certainly not sufficient to guarantee safe operation of a plant or machine.

▶ 8.4 Hydraulic design

8.4.1 Basic physical knowledge

In hydraulics the talk is of hydrodynamic energy transfer, e.g. a pump transfers mechanical energy to the oil and flow energy is used to drive a turbine wheel, for example.

8.4.2 Advantages of hydrostatic energy transfer

The following advantages play a role in hydrostatic energy transfer:

- ▶ Transfer of high forces and powers in the smallest possible space
- ▶ Sensitive, infinitely variable control of speeds
- ▶ Smooth speed control under load, within a large setting range
- ▶ Large transmission range on drives
- ▶ Quiet operation, fast, smooth reversal of motion
- ▶ Simple, safe overload protection
- ▶ High switch-off accuracy when stopping the operating component
- ▶ Long service life and low plant maintenance as the sliding components are automatically lubricated by the hydraulic fluid

8.4.3 Disadvantages of hydrostatic energy transfer

The following disadvantages should be mentioned:

- ▶ Operation accuracy changes in the event of oil viscosity fluctuations due to temperature variation
- ▶ Sealing problems, particularly when there are high system pressures and temperatures
- ▶ Air dissolves in hydraulic fluid. Air bubbles are created when the pressure drops, adversely affecting control accuracy
- ▶ Hydraulic fluids are channelled in a loop with cooler and filter

8.4.4 Definitions

- ▶ Fluid power: The means whereby signals and energy can be transmitted, controlled and distributed using a pressurised fluid or gas as the medium
- ▶ System: Arrangement of interconnected components that transmits and controls fluid power energy
- ▶ Component: An individual unit (e.g. cylinder) comprising one or more parts designed to be a functional part of a fluid power system
- ▶ Hydraulics: Science and technology which deals with the use of a liquid as the pressure medium
- ▶ Maximum working pressure: The highest pressure at which a system is intended to operate in steady-state conditions
- ▶ Rated pressure: The highest pressure at which the component is intended to operate for a number of repetitions sufficient to assure adequate service life
- ▶ Control device: A device that provides an input signal to an operating device (switch)
- ▶ Operating device: A device that provides an output signal to a component (solenoid)
- ▶ Piping: Any combination of fittings, couplings or connectors with pipes, hoses or tubes, which allows fluid flow between components

▶ 8.4 Hydraulic design

8.4.5 General hydraulic relationships

8.4.5.1 Pressure, absolute pressure and overpressure

Pressure p is the force applied to area A , also called pressure for short. The amount of pressure at any point is irrespective of the position. The unit of measurement for pressure is defined with pascal using the base units of the International System of Units: kilogram, metre and second.

Absolute pressure: The absolute pressure scale starts at $p_{abs} = 0$, as absolute pressure is the zero pressure of a vacuum.

Overpressure: The difference between absolute pressure and the existing atmospheric pressure p_{amb} is called overpressure.

Piston pressure force

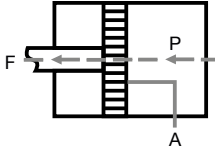
Graphic	Equation/equation conversion	Formula symbol/units
	$F = 10 \times p \times A$ $F = p \times A \times \eta \times 10$ $A = \frac{d^2 \times \pi}{4}$ $A = \sqrt{\frac{4 \times F \times 0,1}{\pi \times p}}$ $p = 0,1 \times \frac{4 \times F}{\pi \times d^2}$	<p>F = Piston pressure force [N] p = Hydraulic pressure [bar] A = Piston area [cm²] d = Piston diameter [cm] η = Cylinder efficiency factor</p>

Piston forces

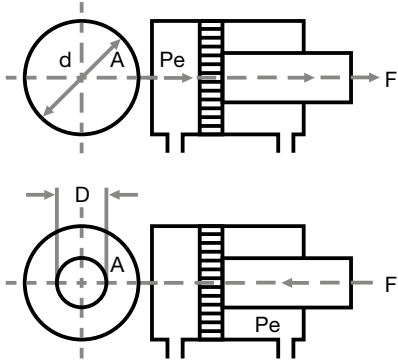
Graphic	Equation/equation conversion	Formula symbol/units
	$F = Pe \times A \times 10$ $F = Pe \times A \times \eta \times 10$ $A = \frac{d^2 \times \pi}{4}$ <p>A for circular ring area:</p> $A = \frac{(D - d^2) \times \pi}{4}$	<p>F = Piston pressure force [N] Pe = Excess pressure on the piston [bar] A = Effective piston area [cm²] d = Piston diameter [cm] η = Cylinder efficiency factor</p>

► 8.4 Hydraulic design

Piston speed

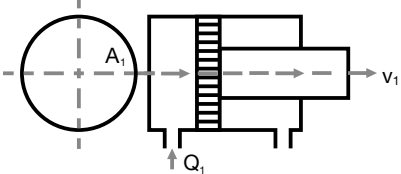
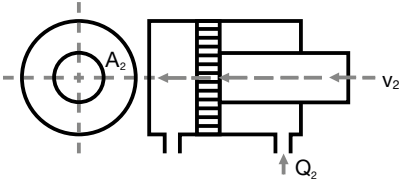
Graphic	Equation/equation conversion	Formula symbol/units
	$v_1 = \frac{Q_1}{A_1}$ $v_2 = \frac{Q_2}{A_2}$ $A_1 = \frac{d^2 \times \pi}{4}$ $A_2 = \frac{(D^2 - d^2) \times \pi}{4}$	$v_{1,2}$ = Piston speed [cm/s] $Q_{1,2}$ = Volume flow rate [cm ³ /s] A_1 = Effective piston area (circle) [cm ²] A_2 = Effective piston area (ring) [cm ²]
		

8.4.5.2 Pascal's law

Pascal's law is the basic law of hydrostatics and applies to incompressible fluids at rest:

Pressure exerted anywhere in a confined fluid is transmitted equally to the internal wall of the container and to the fluid.

8.4.5.3 Gravitational pressure

The pressure p_h generated in the fluid by gravity alone is determined by

$$p_h = \rho \times g \times h$$

- ρ : Density of the fluid
- g : Gravitational constant (= 9.81 m/s²)
- h : Height of the liquid column

When designing hydraulic systems it is necessary to check whether the gravitational pressure is of any notable size compared with the pressures occurring within the system. Generally the gravitational pressure is not of any note because it is often less than the required system pressure.

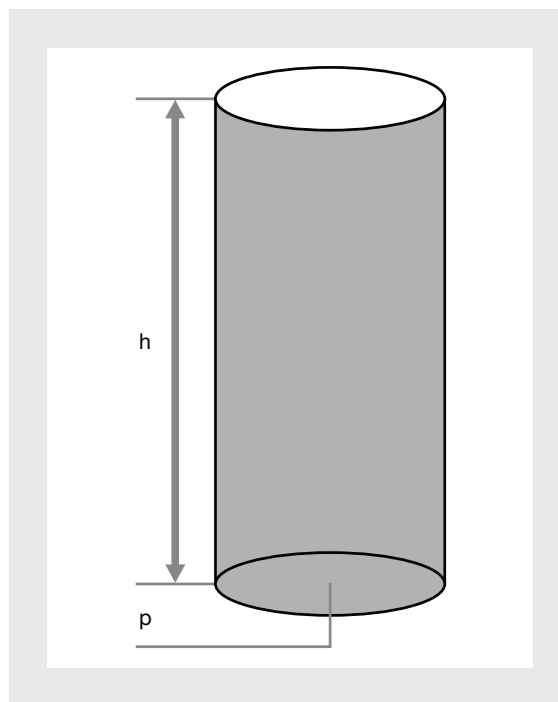

Gravitational pressure

▶ 8.4 Hydraulic design

8.4.5.4 Force and path transmission

The principle of force and path transmission can be best explained using the example of an hydraulic press: In accordance with Pascal's law, the pressure p generated by the force F_1 is transmitted equally to all parts of the fluid and to the area A_1 . This gives:

In this way, it is possible to illustrate the principle of force transmission: For example, if the area A_2 is ten times greater than the area A_1 ($A_2=10 \cdot A_1$), the force F_1 will also be transmitted at ten times its value to the force F_2 . At the same time, the path travelled S_1 is transmitted as a 10th of S_2 .

Force and path transmission

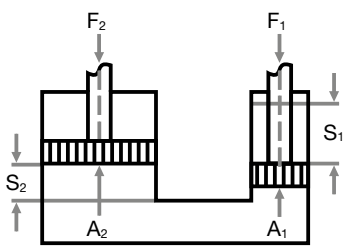
Graphic	Equation/equation conversion	Formula symbol/units
	$\frac{F_1}{A_1} = \frac{F_2}{A_2}$ $F_1 \times s_1 = F_2 \times s_2$ $\varphi = \frac{F_1}{F_2} = \frac{A_1}{A_2} = \frac{s_2}{s_1}$	<p>F_1 = Force on the pump piston [N] F_2 = Force on the working piston [N] A_1 = Area of pump piston [cm²] A_2 = Area of working piston [cm²] s_1 = Travel of pump piston [cm] s_2 = Travel of working piston [cm] φ = Transmission ratio</p>

8.4.5.5 Pressure transmission

The principle of pressure transmission:

Pressure intensifier

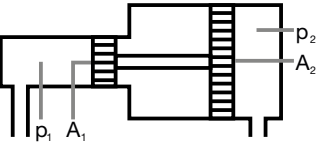
Graphic	Equation/equation conversion	Formula symbol/units
	$p_1 \times A_1 = p_2 \times A_2$	<p>p_1 = Pressure in the small cylinder [bar] A_1 = Piston area [cm²] p_2 = Pressure on the large cylinder [bar] A_2 = Piston area [cm²]</p>

If, for example, the area A_1 is twice the size of area A_2 ($A_1=2 \cdot A_2$), the pressure p_1 will be transmitted at double its value as p_2 .

8.4.5.6 Hydraulic work

On the hydraulic press, if piston 1 is moved downwards along the path S_1 with the area A_1 and force F_1 , the hydraulic work executed in the process is W_1 . The hydraulic work executed at piston 2 with area A_2 during this process is W_2 .

8.4.5.7 Volumetric efficiency factor

This takes into account the volumetric losses resulting from leakage flows. The hydraulic-mechanical efficiency factor gauges the losses resulting from flow losses and sliding machine parts.

► 8.4 Hydraulic design

8.4.5.8 Continuity equation

Prerequisite: A fluid flows through a tube with various cross sectional areas. As no fluid is lost between the various cross sectional areas, the following applies for the mass flows that stream through these areas:

$$A_1 \times V_1 = A_2 \times V_2 = A_3 \times V_3 = \text{const.}$$

Continuity equation

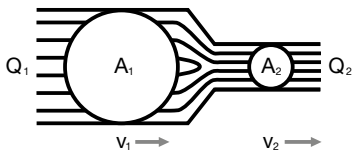
Graphic	Equation/equation conversion	Formula symbol/units
	$Q_1 = Q_2$ $Q_1 = A_1 \times v_1$ $Q_2 = A_2 \times v_2$ $A_1 \times v_1 = A_2 \times v_2$	$Q_{1,2}$ = Volume flow rates [cm ³ /s, dm ³ /s, m ³ /s] $A_{1,2}$ = Cross-sectional areas [cm ² , dm ² , m ²] $v_{1,2}$ = Flow speeds [cm/s, dm/s, m/s]

8.4.5.9 Bernoulli's equation

Bernoulli's equation is a special case derived from the familiar Navier-Stokes equation from fluid mechanics, which applies to three-dimensional viscous flows. The equation for the energy form is:

$$\frac{V^2}{2} + g \times z + \frac{p}{\rho} = \text{const.}$$

8.4.5.10 Flow forms

Laminar or turbulent flow forms occur in the tubes of hydraulic systems. With a laminar flow, the fluid particles move in orderly, separate layers, which is why we talk of a flow direction. The flow lines run in parallel to the tube axis. With a turbulent flow, the fluid no longer moves in orderly layers.

The main axial flow is now superimposed on all points through random longitudinal and transverse movements, that result in a disturbed flow. The flow is thereby mixed. The transition from a laminar to a turbulent flow occurs at velocity of flow v_{crit} in straight tubes with a circular cross section d and viscosity of the fluid ν when the critical Reynolds number $Re_{\text{crit}} = 2,300$.

$$v_{\text{crit}} = \frac{Re_{\text{crit}} \times \nu}{d}$$

► 8.4 Hydraulic design

8.4.5.11 Viscosity

A surface-mounted plate with an area A is moved at constant speed v on a fluid layer with a defined height h . The force F is required to maintain the movement. If the layer thickness h is not too great, a linear velocity gradient dv/dz develops between the plate and the bottom of the fluid.

The law discovered by Newton

$$\frac{F}{A} = \tau = \eta \times \frac{dv}{dz}$$

τ stands for the friction shear stress and η for the dynamic viscosity of the fluid, which as a property represents a measurement for the internal friction, which makes it more difficult for the fluid particles to move. The energy expended in moving the particles is converted into heat. The definition of the viscosity used in hydraulics:

$$[\eta] = \text{N} \times \frac{\text{s}}{\text{m}^2} \quad v = \frac{\eta}{\rho}$$

is known as Newton's law of friction.

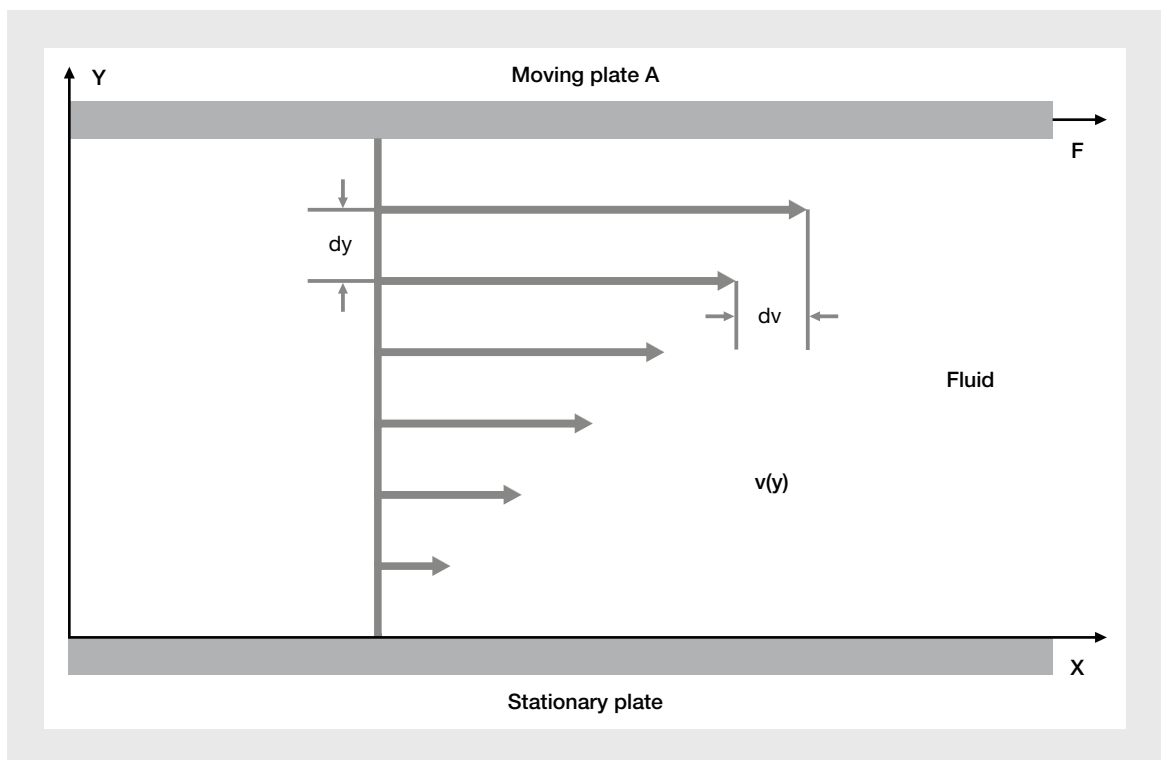

Newton's law of friction

► 8.4 Hydraulic design

8.4.5.12 Pressure losses in tubes, fittings and valves

When fluid flow is friction-free, the total energy comprising pressure energy, kinetic and potential energy is constant. With real fluid flows (subjected to friction), due to the influence of the viscosity, part of the flow energy is converted into thermal energy, which cannot be utilised technically and is therefore also referred to as flow loss. Only pressure energy can be affected by losses due to frictional influences. Considerable pressure losses can occur in fittings (tube bends, tube branches, extensions, narrowings) due to frictional influences. The calculated resistance coefficient is used for the numeric simulation.

8.4.5.13 Cavitation

Cavitation describes the formation of bubbles (air and steam bubbles) on bottlenecks in hydraulic components due to pressure drops and the sudden breakdown of these bubbles once the bottleneck is passed. A distinction is made between two types of cavitation: Air bubble cavitation and steam bubble cavitation. Both types of cavitation have similarly negative effects on the components in hydraulic systems.

8.4.5.14 Air bubble cavitation

One property of fluids is the ability to dissolve gases. In this context, we talk of the gas dissolving capacity of fluids. Hydraulic oils in particular contain air in a dissolved state. As well as being present in a dissolved state, air can also occur as air bubbles within the oil. This happens when the oil's static pressure on-site drops to the dissolved gas pressure and therefore the oil's capacity to absorb air is exhausted.

8.4.5.15 Steam bubble cavitation

This occurs when steam bubbles are formed in the oil because the static pressure drops to or below the steam pressure of the oil. Here too, the pressure drops due to the increased flow rates present at bottlenecks in hydraulic components.

8.4.5.16 Hydro pumps

At the heart of any hydraulic system is the hydro pump. The mechanical energy fed via its drive shaft, generally through an electric motor, is needed to increase the energy or pressure of the oil flowing through the pump and to cover all the losses that occur within the pump. The energy of the flow rate leaving the pump's pressure port, also known as hydrostatic energy, is then available to operate hydraulic applications. Hydro systems generally require high pressures at low flow rates; only in rare cases are these greater than 300 l/min. For this reason, centrifugal pumps are not suitable for this type of application. Hydro pumps operate in accordance with the displacement principle, like radial piston pumps for example. This system is based on the reducing and expanding space. The displacement volume, also known as stroke volume, is understood to be the volume of oil delivered when a pump rotates.

On hydro pumps, the distinction is made between constant and variable pumps. On constant pumps, the displacement volume V_i cannot be varied. On variable pumps, the displacement volume V_i is a changeable variable and is dependent on the volume setting. The theoretical flow rate of the pump is calculated by multiplying the displacement volume by the pump speed.

► 8.4 Hydraulic design

8.4.6 Structure of a hydraulic system

The hydraulic circuit diagram shows the structure of a hydraulic circuit. The individual hydraulic devices are represented by standardised symbols and are interconnected through pipelines. The diagrams that follow illustrate simple hydraulic circuits. In this case, the devices are not represented by standardised symbols but are shown schematically to identify their mode of operation. The pump sucks the hydraulic oil from the container and pushes it into the pipeline system containing the built-in devices. The oil flows from P to B through a directional valve in the hydro cylinder. The piston (with tool) creates resistance for the oil. The pressure rises in the power section between the pump and piston until the piston force is sufficient to overcome the load and the piston moves.

8.4.7 Simple hydraulic circuit, upward movement

The directional valve is held in position by any amount of actuation force. The piston travels to the top end position. The displaced oil flows through the directional valve from A to T, back to the tank. The directional valve therefore controls the direction of the oil flow. To ensure that the system is protected from excessive loads (pressures), a pressure limiting valve is installed in the pressure line, after the pump. If the set pressure is exceeded, the valve will open and the remaining oil will flow into the tank. The pressure will not increase any further.

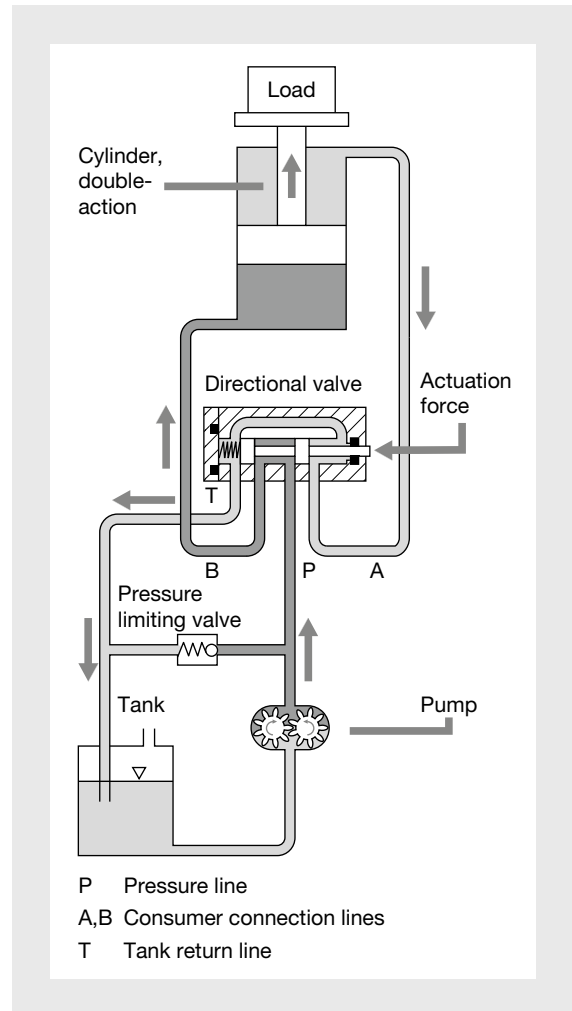

Structure of a hydraulic system

► 8.4 Hydraulic design

8.4.8 Simple hydraulic circuit, downward movement

When the actuation force is removed, the directional valve is reset via spring force. Now the oil flows from P to A to the rod side of the piston. The piston moves towards the bottom end position, the displaced oil flows through the directional valve from B to T, back to the tank. Switching the directional valve enables the piston to continuously move back and forth.

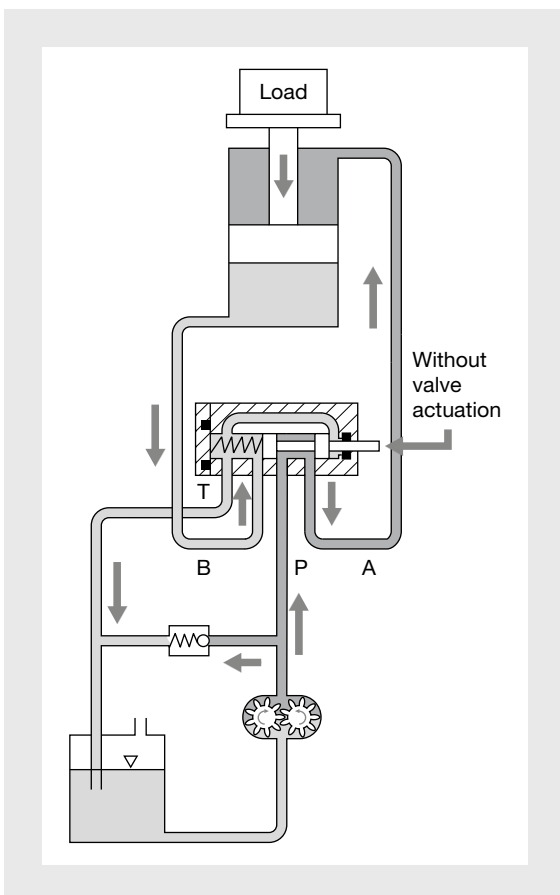

Downward movement on a simple hydraulic circuit

8.4.9 Simple hydraulic circuit, speed

If it's necessary to control not only the direction of the piston but also the speed, the amount of oil flowing in and out of the cylinder will need to be varied. This can be done using a choke valve: If the valve cross section is reduced, less oil will flow into the cylinder over a defined unit of time. The oil flow is less than before it was choked, so the piston speed will also be slower, in accordance with the continuity equation. In other words, the piston speed is proportional to the oil flow. So the speed is controlled by controlling the oil flow.

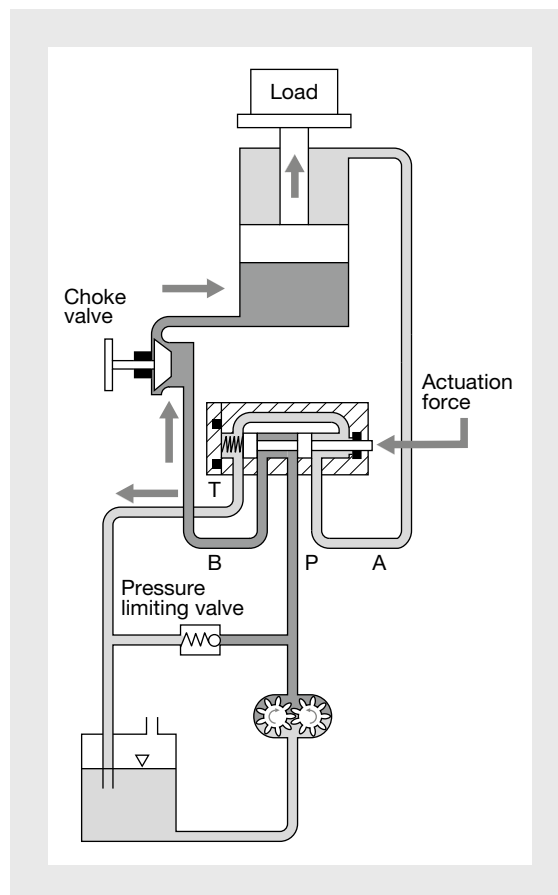

Speed control on an individual hydraulic circuit

► 8.4 Hydraulic design

8.4.10 Circuit diagram for a simple hydraulic circuit

The hydraulic process described above is illustrated below as a hydraulic circuit diagram. The directional valve is manually operated. When unoperated it is held in the spring-centred middle position by spring force.

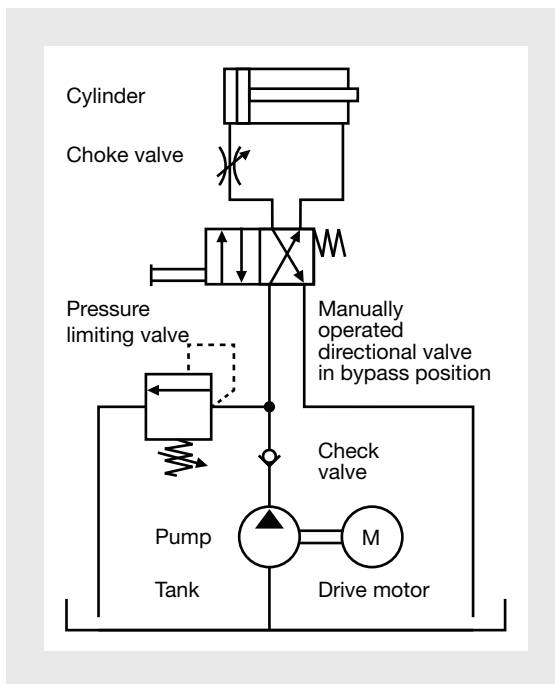

Circuit diagram for a simple hydraulic circuit

► 8.4 Hydraulic design

8.4.11 Two-cylinder controllers with electric valves

If two or more cylinders are to be used on a hydraulic system, various requirements can be associated with their use, and these can be implemented using various circuit types:

- Sequential circuits
- Synchronous circuits
- Series circuits
- Parallel circuits

The diagram below shows a sequential circuit (sequential circuit with limit switches and solenoid valves): In the version with limit switches, the limit switches actuate the piston rods, based on the path (the electrics are not shown):

1. Start: Solenoid Y1 is energised, directional valve 1 to the left, piston on cylinder 1 to the right
2. Limit switch 2 actuated: Solenoid Y1 de-energised, solenoid Y3 energised, directional valve 2 to the left, piston on cylinder 2 to the right
3. Limit switch 4 actuated: Solenoid Y3 de-energised, solenoid Y2 energised, directional valve 1 to the right, piston on cylinder 1 to the left
4. Limit switch 1 actuated: Solenoid Y2 de-energised, solenoid Y4 energised, directional valve 2 to the right, piston on cylinder 2 to the left
5. Limit switch 3 actuated: Solenoid Y4 de-energised, solenoid Y1 energised, directional valve 1 to the left, piston on cylinder 1 to the right (continue with step 2)

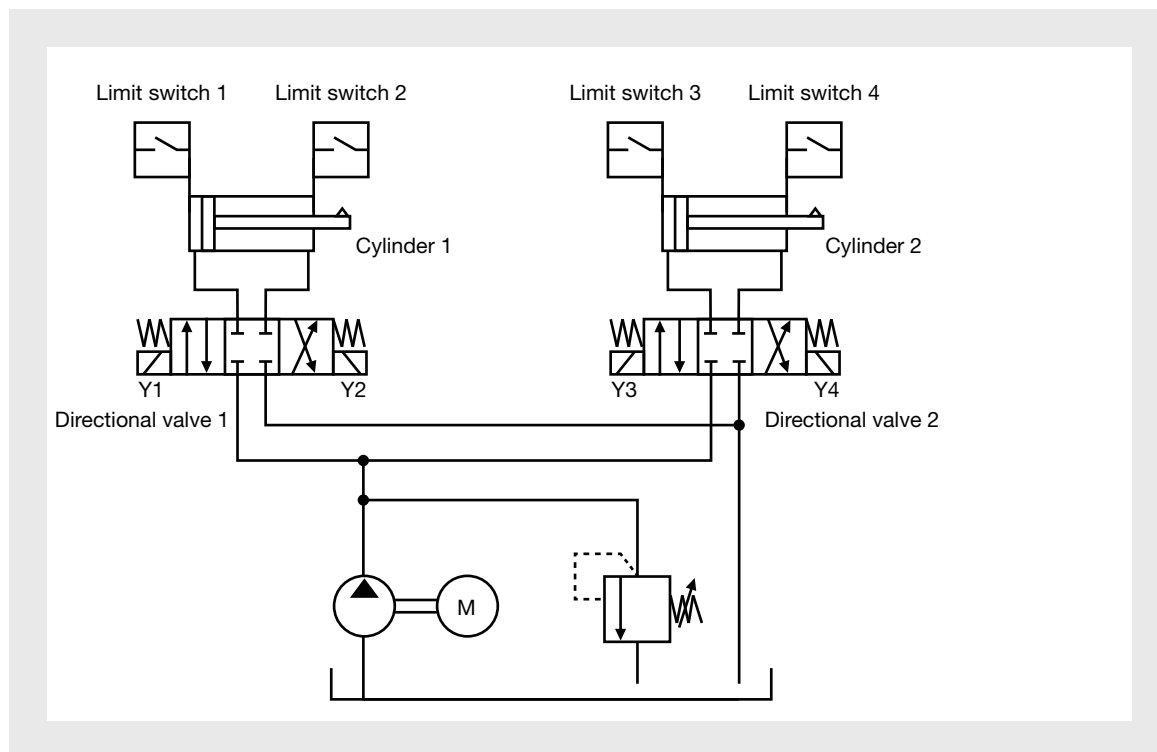

Circuit diagram for two-cylinder controllers with electric valves

► 8.4 Hydraulic design

8.4.12 Two-cylinder controllers with sequence valves

The sequence valves 1 and 2 are pressure valves which open at a certain pressure, which can be selected. They close again when the pressure drops. This results in the following motion sequence:

1. Left directional valve is activated: The piston side of cylinder 1 is pressurised, the cylinder extends. When the piston stops, the pressure rises above the pressure set on the pressure limiting valve.
2. Sequence valve 1 opens: The fluid flows to the piston side of cylinder 2, this cylinder also extends.
3. Right directional valve is activated, the rod side of cylinder 2 is pressurised, the cylinder retracts. When the piston stops, the pressure rises above the pressure set on the pressure limiting valve.
4. Sequence valve 2 opens: The fluid flows to the rod side of cylinder 1. This piston also retracts.

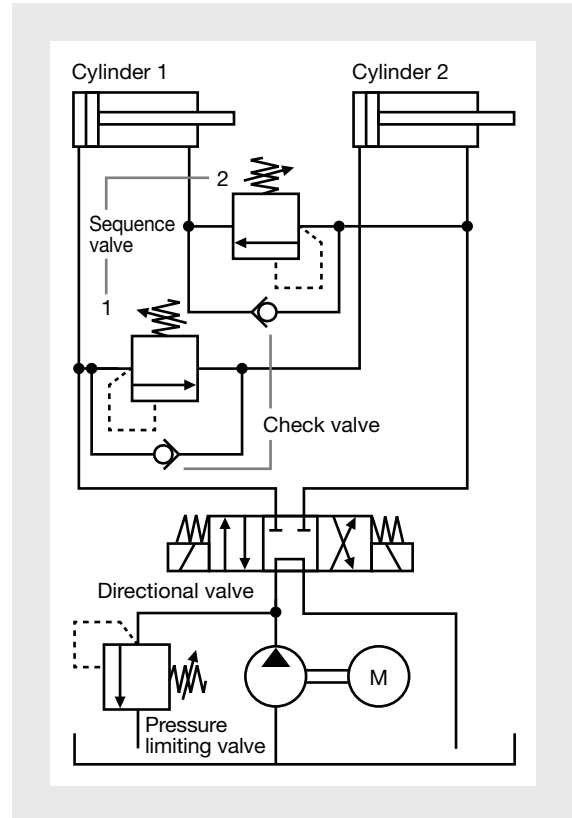

Circuit diagram for two-cylinder controllers with sequence valves

► 8.4 Hydraulic design

8.4.13 Series circuit

A series circuit is implemented as with valves connected in series. The return line is not guided back into the tank, as with a single circuit, but to the directional valve on the second cylinder. If both cylinders are operated simultaneously in this type of circuit, the piston force and piston speed will influence each other. The result is the following relationships: System pressure p , which acts upon the piston area of cylinder 1, must be large enough not only to generate its own lifting force F_1 , but also to overcome the counteracting force F_{G1} generated by cylinder 2. This counteracting force comes from the fact the oil pressure needed to operate cylinder 2 in turn acts upon the piston ring area of cylinder 1. The ring area of cylinder 1 displaces the oil and conveys it to cylinder 2. Its speed depends therefore on the return flow rate from cylinder 1. The relationship between the extending speed of cylinder 1 and the extending speed of cylinder 2 is the same as the relationship between the piston area of cylinder 2 and the ring area of cylinder 1.

8.4.14 Parallel circuit

In contrast to a series circuit, with a parallel circuit there is no mutual influencing when all the cylinders operate simultaneously. Oil is supplied via a branch pipe line. The system pressure set at the pressure limiting valve prevails as far as the directional valves. With a parallel circuit, sufficient fluid must be available to maintain the necessary system pressure if the cylinders are to be extended simultaneously. If the pump conveys too little fluid, the cylinder with the lowest operating resistance will extend first. If it is in the end position, the pressure continues to rise until it is sufficient for the next cylinder. So the extension of the cylinders depends on the necessary operating pressure.

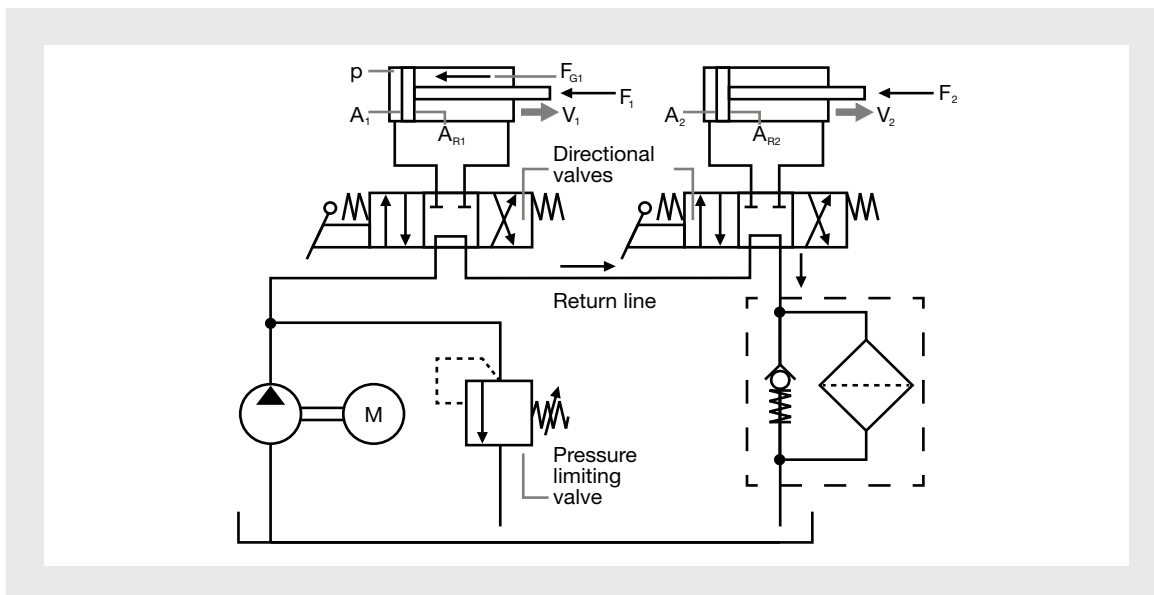

Circuit diagram for a series circuit

► 8.4 Hydraulic design

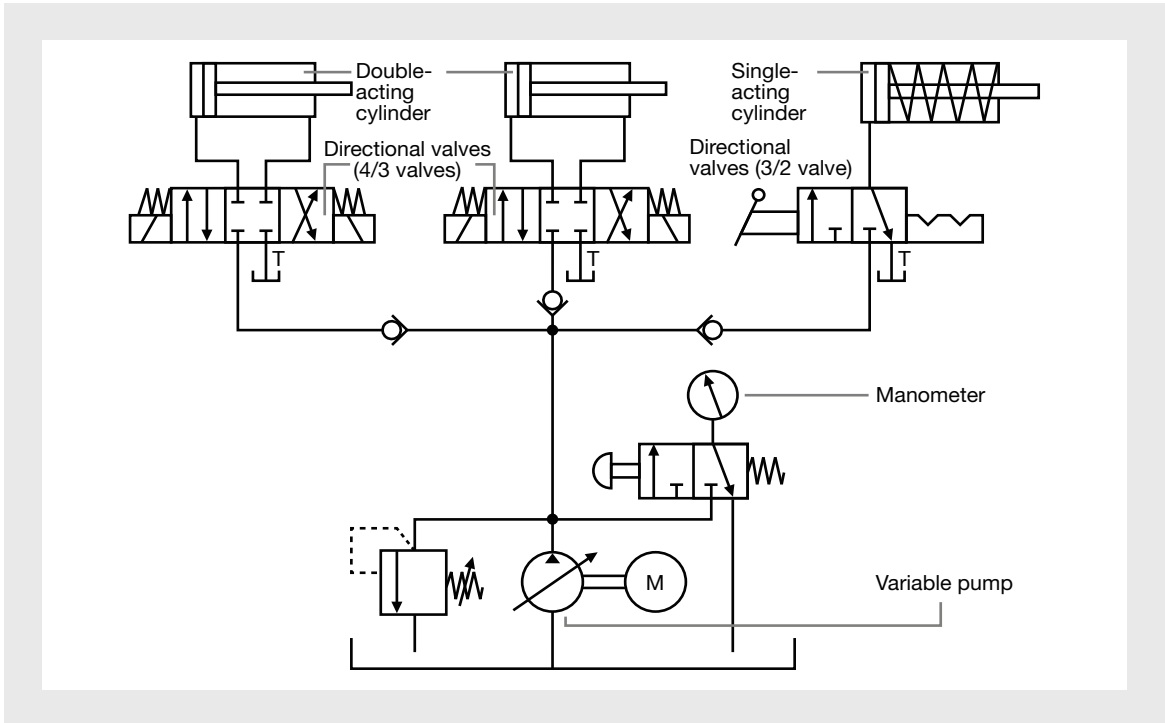

Circuit diagram for a parallel circuit

8.4.15 Differential circuit

The rod chamber is constantly under pressure, the piston chamber is connected to a directional valve. This circuit is called a differential circuit because the force acting upon the piston rod is expressed as a ratio of piston area to rod area. The differential circuit is used when the piston must be hydraulically clamped and the pump must be as small as possible or a rapid movement of the piston is required. If the piston extends via the directional valve, the fluid dispersed from the ring area will be combined with the pump flow ahead of the directional valve and will be fed back to the piston side of the cylinder. With this circuit, the force exerted by the piston rod is calculated from the product of pressure times rod area.

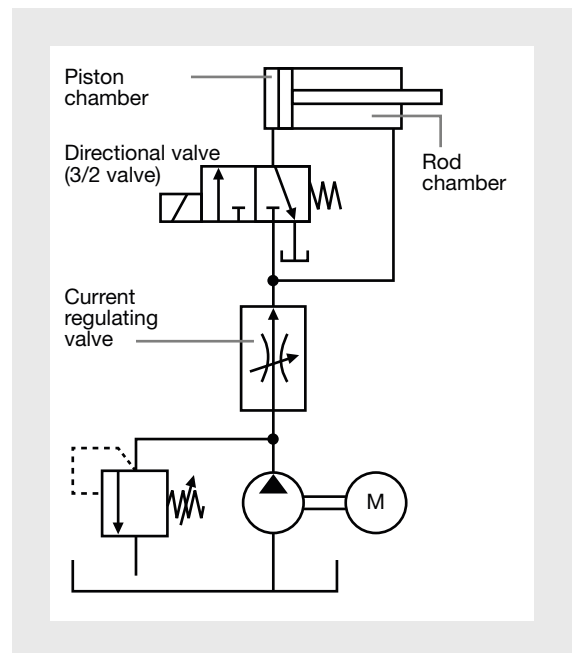

Circuit diagram for a differential circuit

► 8.4 Hydraulic design

8.4.16 Speed controllers

Flow valves are used for speed control. Flow valves are choke valves or flow control valves. There are two options: primary or secondary control.

Primary control: With primary control, the flow valve sits in the inlet between the directional valve and the cylinder. It controls the inflowing hydraulic fluid. The graphic symbol shows a two-way flow control valve. A check valve is connected in parallel, which blocks the inflow but lets the return flow through. As a result, the fluid flows through the flow valve only on the infeed and not on the return. The piston is thus only controlled in one direction. Two flow control valves must be installed if the other direction is also to be controlled. The disadvantage of primary control is that the piston jumps if the operating resistance suddenly drops. A back pressure valve can prevent this.

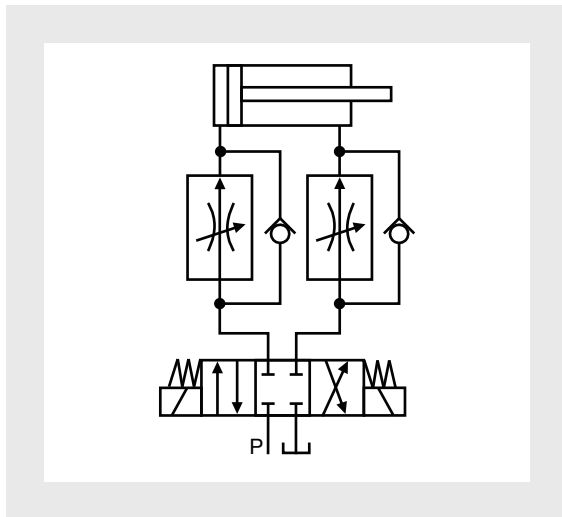

Circuit diagram for primary control

Secondary control: With secondary control, the flow valve sits in the outlet between the directional valve and the cylinder. As such, it controls the return flow. The switch symbol shows a two-way flow control valve. A check valve is connected in parallel, which blocks the return flow but lets the inflow through. As a result, the fluid flows through the flow valve only on the return and not on the infeed. The piston is thus only controlled in one direction. Two flow control valves must be installed if the other direction is also to be controlled. Secondary control does not have the disadvantage that the piston can jump.

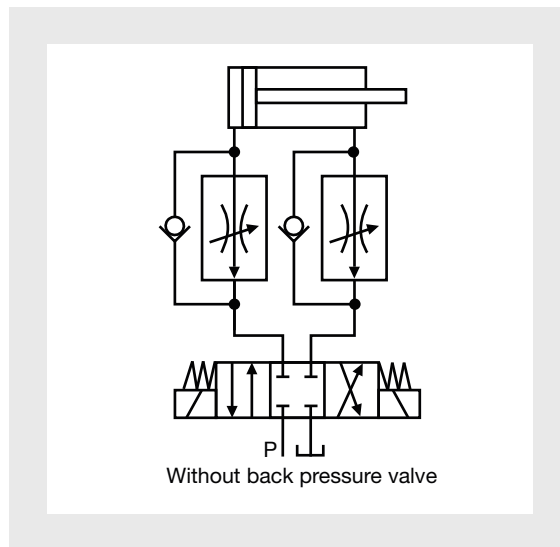

Circuit diagram for secondary control

► 8.4 Hydraulic design

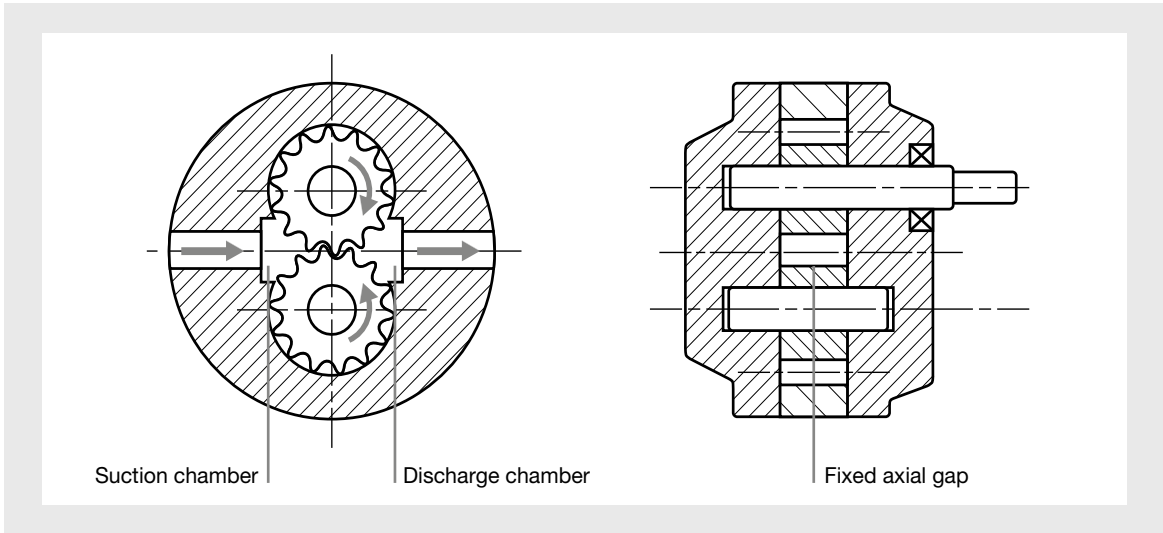

Externally toothed gear pumps

8.4.17 Drive pumps, fixed pumps

Externally toothed gear pump: The fluid conveyed from the suction side to the discharge side is displaced alternately from the gaps through the interlocking cogs. Advantages: Low-cost standard pump with high efficiency factor, which can be connected to other pumps working to the same principle. Disadvantages: High noise level. Application: In open circuits in industrial applications.

Internally toothed gear pumps: A driven pinion shaft (1) carries a gear ring (2). The tooth chambers are filled on the suction side, the filler separates the suction and discharge zone on the discharge side. On the discharge side, the oil is displaced through the gear ring. Advantages: Low-noise standard pump with high efficiency factor, which can be connected to other pumps working to the same principle, lower noise level. Disadvantages: More expensive than the traditional gear pump. Application: In open circuits in industrial applications, where quiet running is an important requirement.

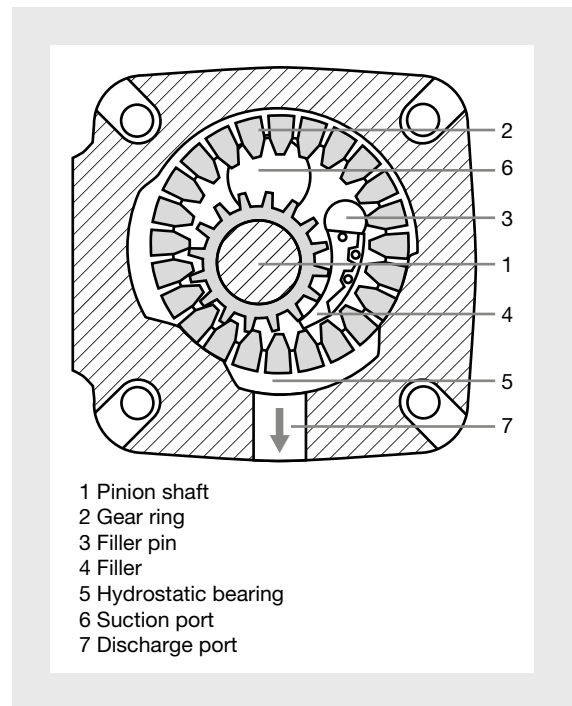

Internally toothed gear pumps

► 8.4 Hydraulic design

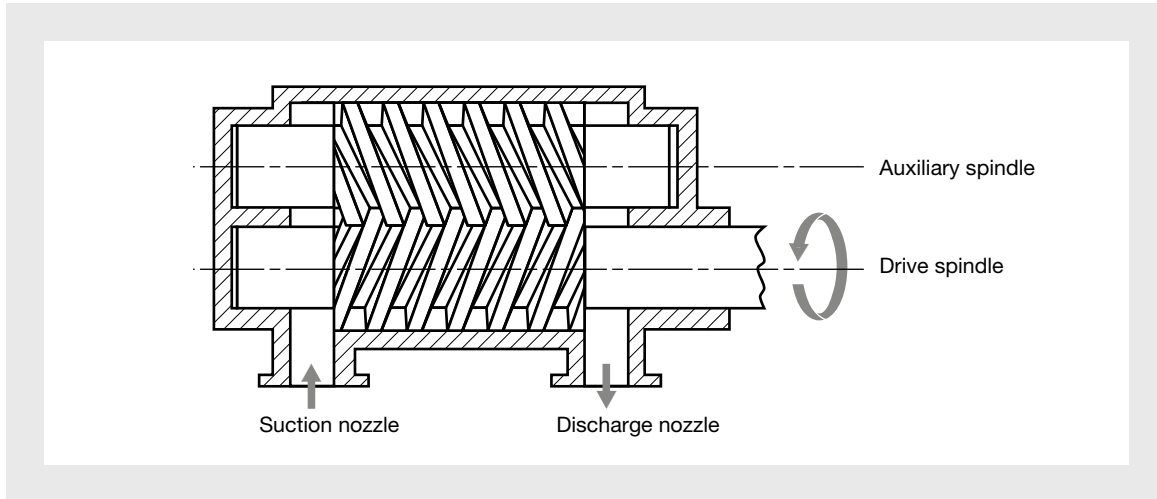

Screw pump

8.4.18 Drive pumps, screw pumps

Two jointly driven meshing spindles form oil chambers within the housing, which are moved from the suction to the pressure nozzle as the spindles rotate. Advantages: Pulse-free flow rate, low noise level. Disadvantages: Relatively low efficiency factor due to high volumetric losses, so high oil viscosity is required. Application: In open circuits in industry; for example, on precision machines and in the lift industry. High volume flows.

► 8.4 Hydraulic design

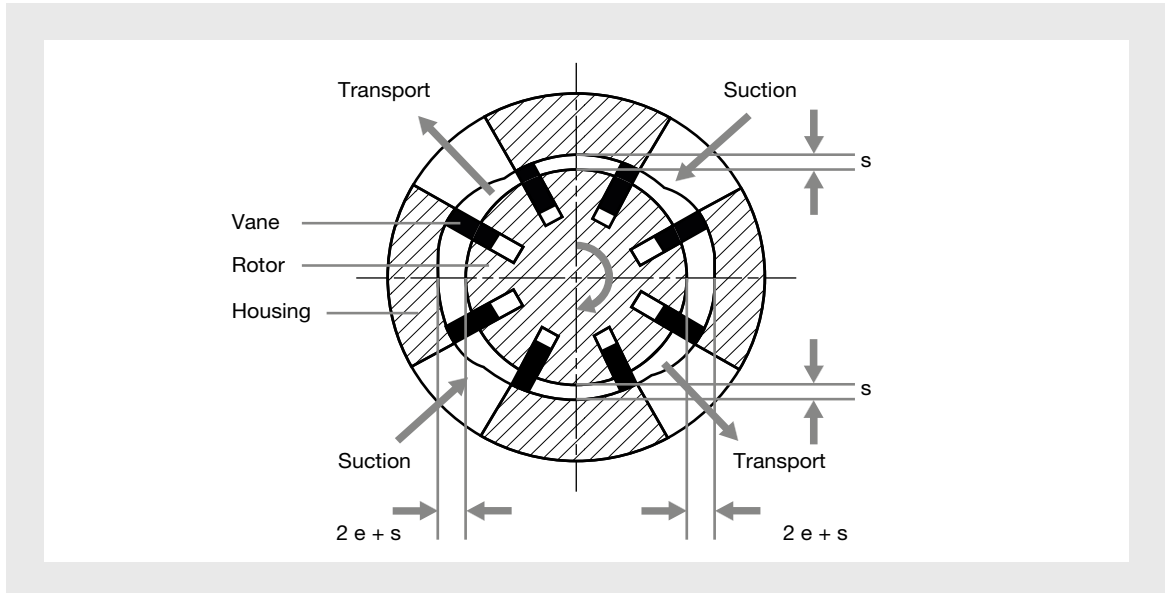

Drive pump with vane cells

8.4.19 Drive pumps, vane pumps

Moving vanes in the slots on the rotor that are pressed against the housing wall by centrifugal force and pressure. The cell size increases in conjunction with the suction port and reduces in conjunction with the discharge port. Advantages: Pulse-free flow rate, low noise level, can be flanged to multi-flow pumps. Disadvantages: Low efficiency factor as gear pumps, more sensitive to dirt. Application: In open circuits in industry; for example, on precision machines with low pressure.

▶ 8.5 Safety requirements on hydraulic circuits

8.5.1 Safety requirements in general

When designing hydraulic systems for machinery, all the intended operating states and applications must be taken into account. To determine the hazards, a risk assessment must be carried out in accordance with EN ISO 12100. As far as is practicable, all identified risks should be designed out of the system where possible. Where this is impossible, appropriate protective measures should be provided.

8.5.2 Concept and design

All safety-related system components should be selected in such a way that they guarantee safety during operation and reliably operate within the limits defined.

- ▶ All parts of the system must be designed to withstand maximum operating pressure or be secured against pressures above the permissible limit values through other protective measures.
- ▶ Preferred safeguards against excess pressure are one or more pressure limiting valves, which restrict pressure in all parts of the system.
- ▶ Systems should be designed, built and configured to minimise pressure surges and pressure increases. A pressure surge and increased pressure must not give rise to any hazard.

8.5.3 Additional safety requirements

Leakages:

- ▶ Leakages that occur in the system must not give rise to any hazard.

Energy supply:

- ▶ The electrical or hydraulic energy supply must not cause a hazard. This is particularly true for
- ▶ Switching the energy supply on or off,
- ▶ Energy reduction,
- ▶ Failure and/or restoration of energy.

Unexpected start-up:

- ▶ The system is to be designed in such a way that, when the pressurised medium is completely isolated, an unexpected restart is prevented.
- ▶ Option for mechanical interlock on stop valves in the stop position, plus removal of pressure in the control system
- ▶ Isolation from the electrical supply (EN 60204-1)

Mechanical movements:

- ▶ These must not lead to a situation in which persons are endangered, whether intentionally or unintentionally.

Low-noise design:

- ▶ Compliance with EN ISO 11688-1 is essential.

Operating temperatures:

- ▶ The temperature of the pressure medium must not exceed the maximum operating temperature stated as the limit value for all the system's components.

Operating pressure range:

- ▶ The operating pressure permissible for the respective plant sections must be complied with.

▶ 8.5 Safety requirements on hydraulic circuits

Couplings or fastenings:

- ▶ Drive couplings and fastenings must be capable of withstanding the maximum torque under all operating conditions on a sustained basis.

Speed:

- ▶ The speed must not exceed the maximum value stated in the manufacturer's documentation.

Lift stops:

- ▶ Appropriate means should be used to secure adjustable lift stops.

Valves with defined switching position:

- ▶ Any drive that must maintain its position or adopt a specific failsafe position in the event of a control failure must be controlled by a valve which guarantees a defined switching position, either via a spring pre-load or an interlocking device.

Hydraulic systems with hydraulic accumulator:

- ▶ Hydraulic systems with hydraulic accumulators are used to automatically regulate the storage fluid pressure. During maintenance work on the system, it is necessary to relieve the pressure in the system to safely shut off the hydraulic accumulator. Hydraulic accumulators and the associated pressurised components must operate within the specified limits, temperatures and environmental conditions.

8.5.4 Establishing compliance with the safety requirements

As a hydraulic system is generally not a complete machine, many test procedures cannot be carried out until the hydraulic system is incorporated into a machine. See below, EN ISO 4413 Chap. 6:

Chap. 6: Establishing compliance with the safety requirements and acceptance test

The hydraulic system must undergo a combination of inspection and testing to confirm that:

- ▶ a) the system and its components comply with the system description;
- ▶ b) the connections of the components in the system comply with the circuit diagram;
- ▶ c) the system including all safety components functions properly; and
- ▶ d) no measurable unintentional leakage occurs for any components excluding an amount of fluid that is not sufficient to form a drop on a cylinder rod after several cycles.

NOTE: As a hydraulic system is generally not a complete machine, many test procedures cannot be carried out until the hydraulic system is incorporated into a machine. A function test must then be performed following installation in accordance with the agreement between the client and the contractor.

The results of the confirmation through inspection and testing must be documented and the report must contain the following information:

- ▶ Type and viscosity of the hydraulic fluid used;
- ▶ Temperature of the hydraulic fluid in the container after the temperature has stabilised.

Important: Permissible leakage is defined as slight wetting insufficient to form a drop.

► 8.5 Safety requirements on hydraulic circuits

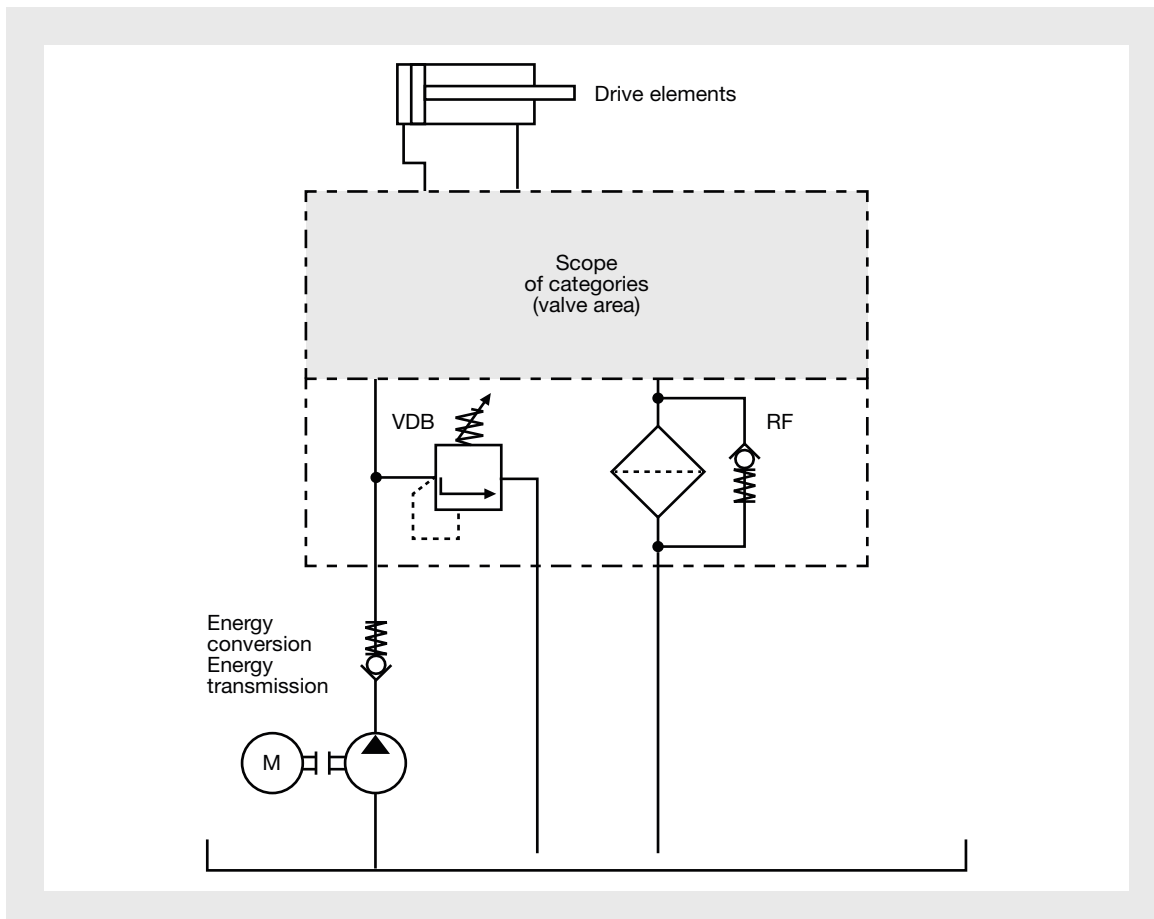

Fluid power system

8.5.5 Safety-related parts of hydraulic controllers

On fluid power systems, any valves that control hazardous movements or conditions should be regarded as safety-related parts of the controller. On hydraulic systems, measures taken to limit pressure within the system (VDB), to filtrate the hydraulic fluid (RF), to monitor the temperature range (T) and to check the fill level of the tank (N) should also be taken into account, although these components are not directly control components.

▶ 8.5 Safety requirements on hydraulic circuits

8.5.6 Controllers in accordance with Category B, Performance Level a as per EN/ISO 13849-1

Category B is the basic category; its requirements apply to all other categories. These requirements also incorporate the basic safety principles. The basic safety principles which are particularly relevant and specific for fluid power systems are:

- ▶ Failure of a component can lead to the loss of the safety function.
- ▶ De-energisation principle (positive signal for starting)
- ▶ Management of energy changes, failure and restoration of energy
- ▶ Pressure limitation within the system
- ▶ Selection of an appropriate hydraulic fluid
- ▶ Sufficient filtration of the pressure medium
- ▶ Avoidance of contamination
- ▶ Isolation of energy supply
- ▶ Compliance with the basic requirements at components (shock, temperature, pressure, viscosity etc.)
- ▶ Safety-related switch position of valves when the control signal is removed (effective springs)
- ▶ Type and condition of the pressure medium

► 8.5 Safety requirements on hydraulic circuits

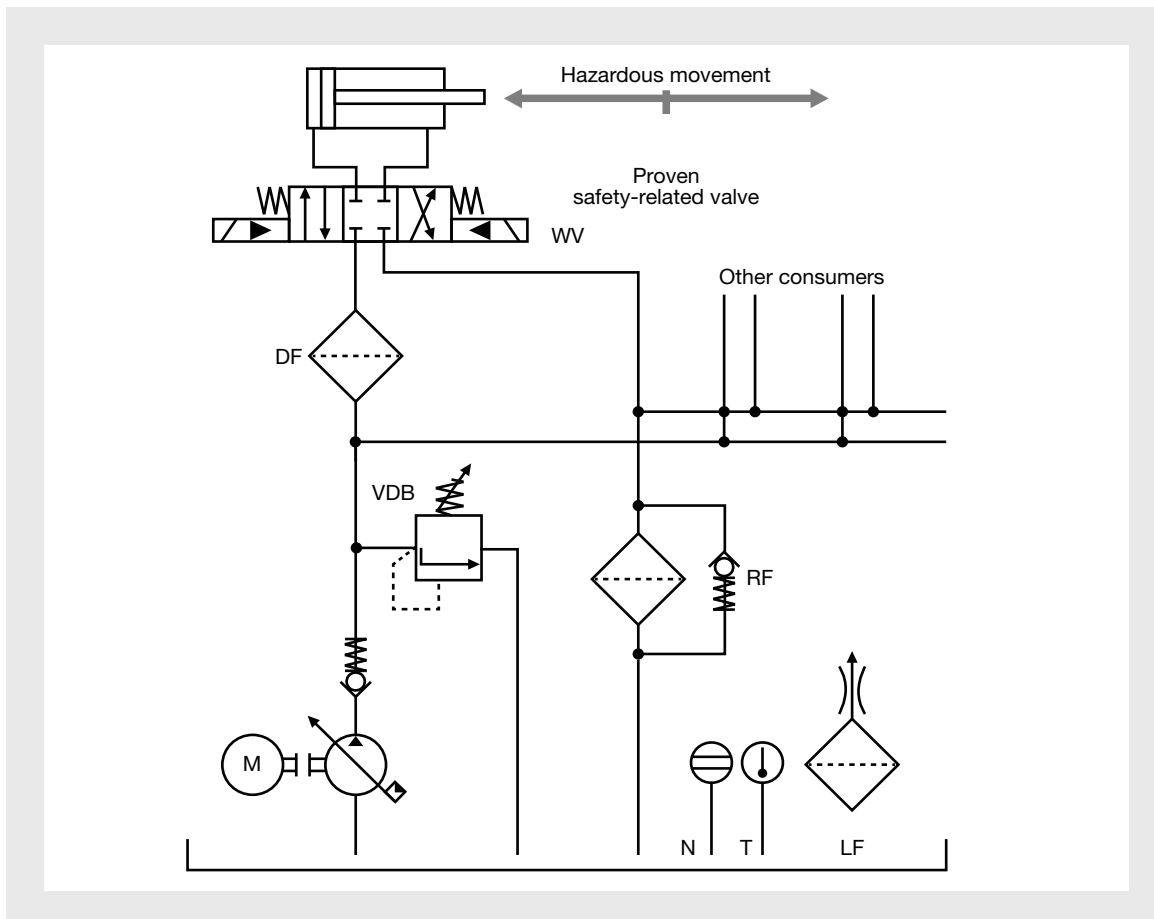

Example of hydraulic circuit (Cat 1, PL b)

8.5.7 Controllers in accordance with Category 1, Performance Level b

In addition to the requirements from Category B, Category 1 controllers must be designed and constructed using well-tries safety principles and well-tries components. General well-tries principles for hydraulics are:

- ▶ Torque/force limitation (reduced pressure)
- ▶ Reduced speed (reduced flow rate)
- ▶ Over-dimensioning
- ▶ Travel limiting jog mode
- ▶ Sufficient positive overlapping in piston valves
- ▶ Positive force (positive mechanical action)
- ▶ Targeted selection of materials and material pairings
- ▶ Expose safety-related springs to at least 10 % below the endurance limit based on 10^7 duty cycles (see EN 13906-1)

► 8.5 Safety requirements on hydraulic circuits

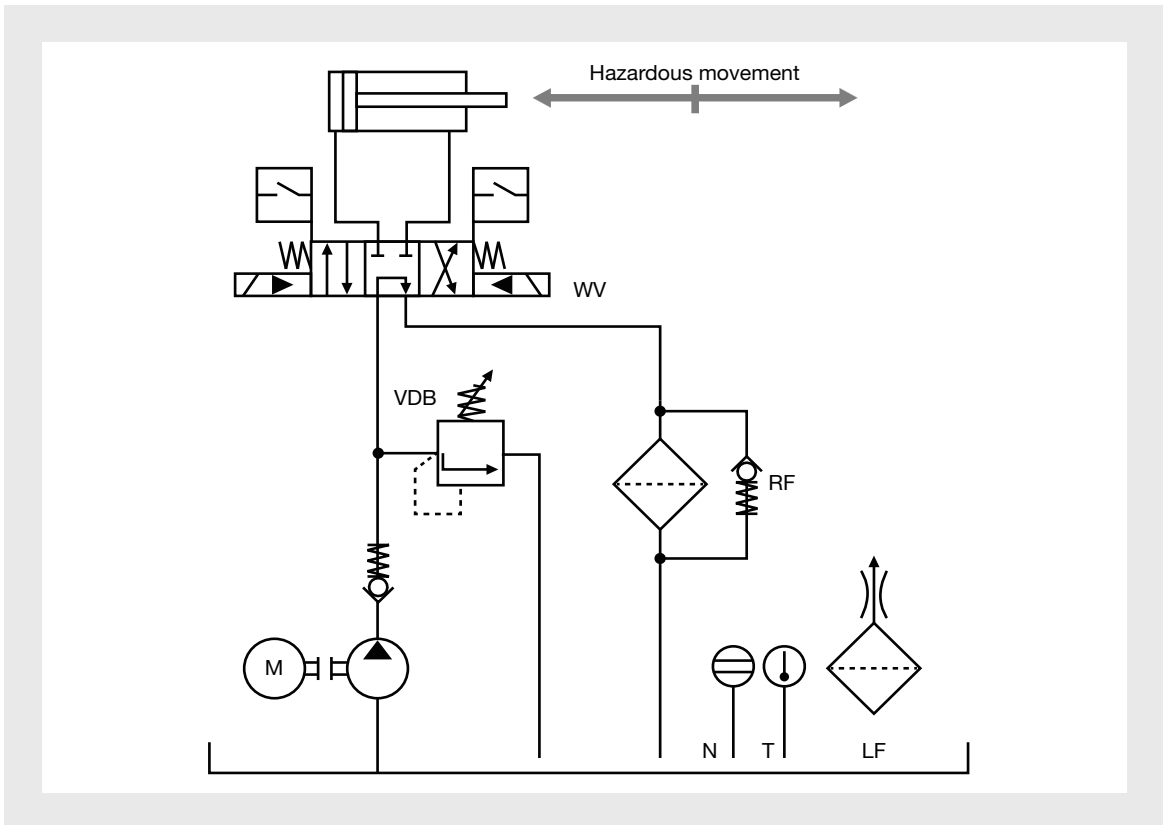

Example of hydraulic circuit (Cat 2, PL b)

8.5.8 Controllers in accordance with Category 2, Performance Level b

In addition to the requirements from Category B and the use of well-tried safety principles, Category 2 controllers must be designed so that the test equipment (TE) is able to check the safety functions at suitable intervals and to react to these.

In the above example, only one directional valve controls the hazardous movement. The electrical machine controller tests the valve's safety function as part of each cycle and on each machine start-up. The failure of the directional valve must not be able to influence the test function. Conversely, if the test function should fail, this must not affect the

reliability of the directional valve. During the test, position switches detect when the valve sliding piston returns to its safety-related middle setting. If the machine controller detects a failure in a directional valve, it immediately triggers a hydraulic pump shutdown.

The total time for detection of the failure and switch to a non-hazardous condition (generally standstill) must be shorter here than the time until the danger point is reached (see also EN ISO 13849-1 and EN ISO 13855).

► 8.5 Safety requirements on hydraulic circuits

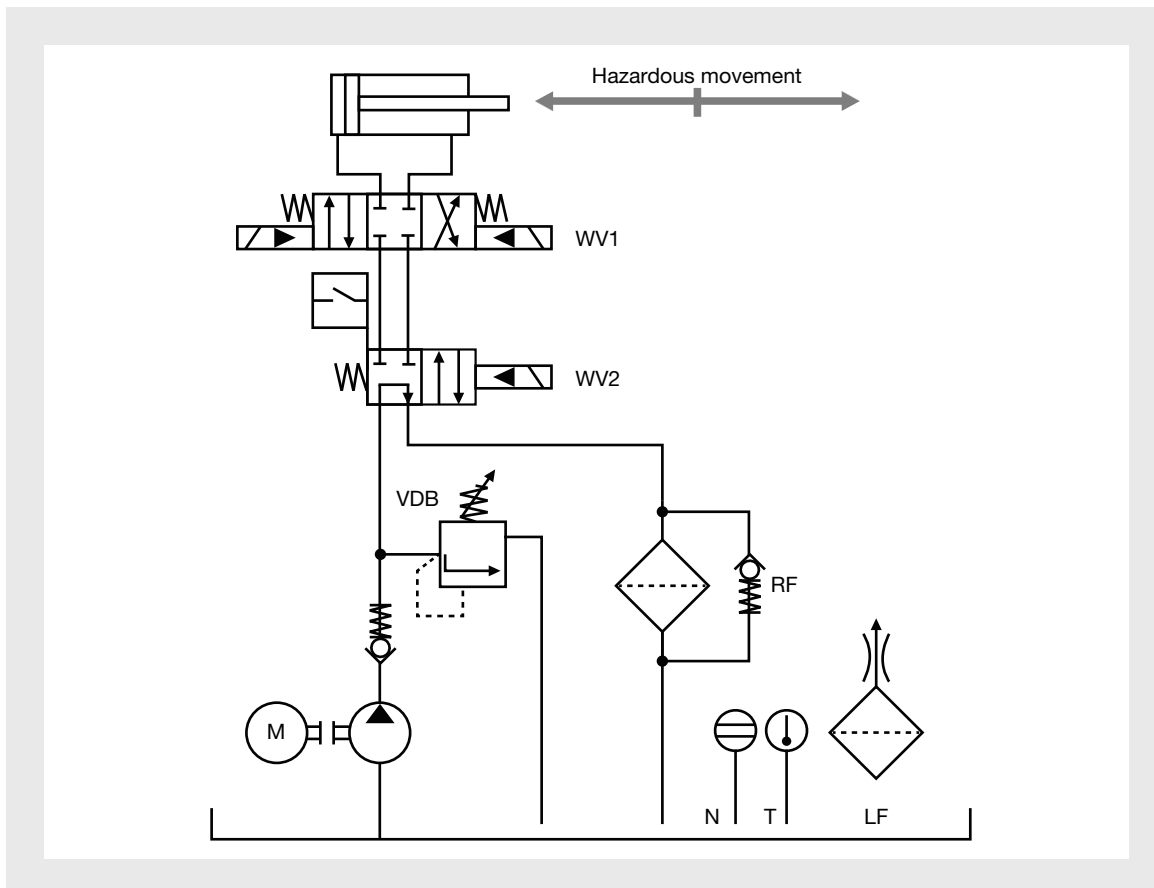

Example of hydraulic circuit (Cat 3, PL d)

8.5.9 Controllers in accordance with Category 3, Performance Level d

In addition to the requirements from Category B and the use of well-tried safety principles, Category 3 controllers must be designed so that a single fault does not lead to the loss of the safety function. Whenever reasonably practicable, a single fault shall be detected at or before the next demand upon the safety function.

Safety-related control of the hazardous movement occurs via the directional valve WW1, which switches as part of each cycle, and via the pressure valve WW2. The additional shutdown of the pump drive motor is not absolutely necessary. The movement of the valve sliding piston WW1 from the safety-related middle setting is not queried in this case; the pressure valve WW2 is switched on redundantly. This provides single fault tolerance. If pressure valve WW2 sticks, this is detected by the electrical position monitoring in the control system. If directional valve WW1 fails, detection during operation is possible if the cylinder is stopped outside the end positions at regular intervals.

► 8.5 Safety requirements on hydraulic circuits

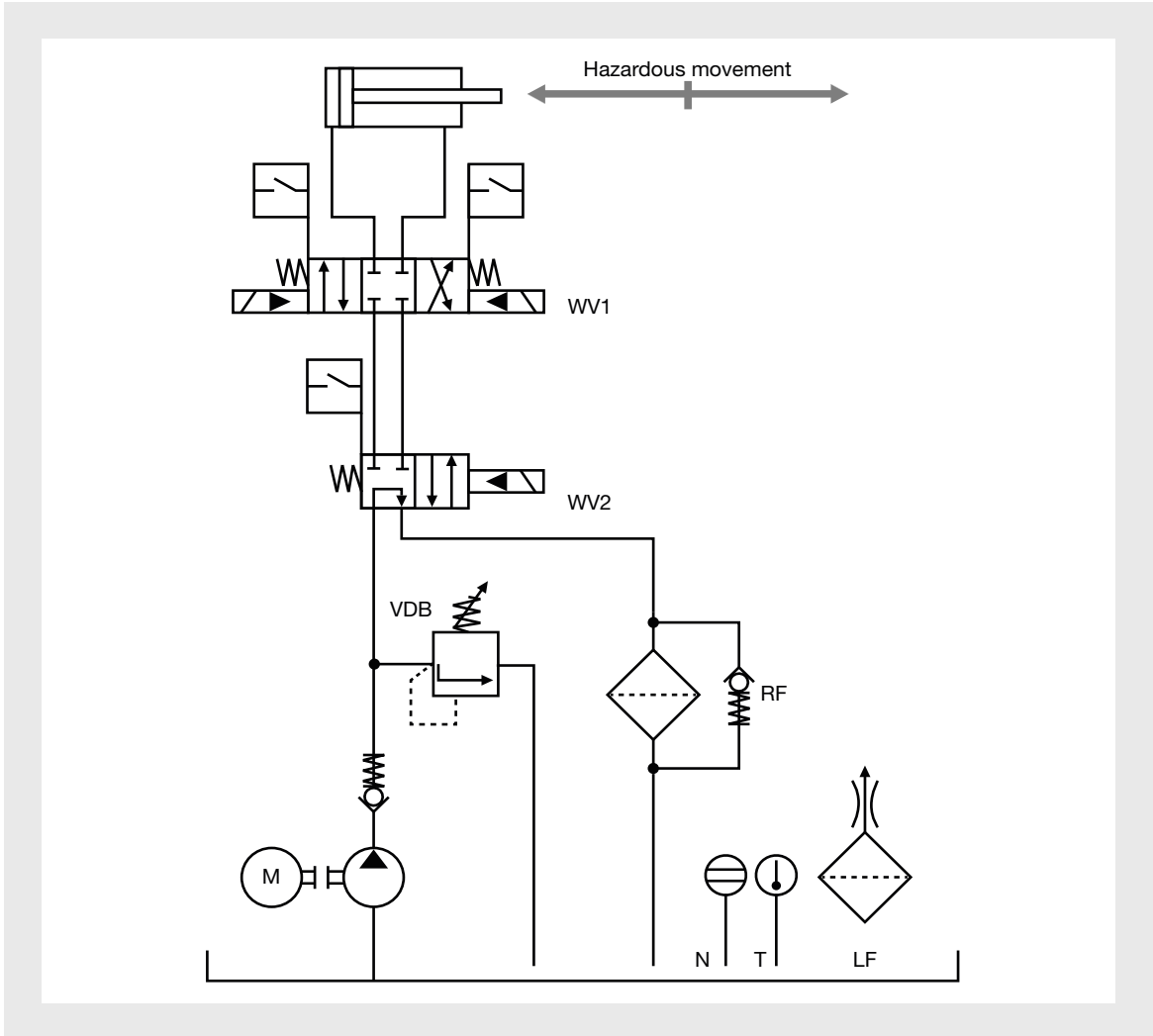

Example of hydraulic circuit (Cat 4, PL e)

8.5.10 Controllers in accordance with Category 4, Performance Level e

In addition to the requirements from Category B and the use of well-tried safety principles, Category 4 controllers must be designed so that a single fault does not lead to the loss of the safety function. The objective of safety concepts is for a single fault to be detected immediately or at the latest before the next demand upon the safety function.

Two valves control the hazardous movement. Each valve is able to shut down the hazardous movement on its own, so single fault tolerance is provided. Both valves are also equipped with electrical position monitoring. This ensures that all possible single faults are detected early by the control system.

► 8.5 Safety requirements on hydraulic circuits

8.5.11 Further example for controllers in accordance with Category 4, Performance Level e

In this hydraulic controller, only the downward movement is monitored in terms of safety (compare hydraulic press). Two electrically monitored valves WV1 and WV3 control the build-up of pressure on the upper side of the piston; valves WV2 and WV1 are responsible for reducing the pressure. Valves

WV1, WV2, WV3 are equipped with electrical position monitoring. Working in conjunction with the control system, this guarantees that all faults are detected. By monitoring the main stage of valve WV2, any failure in the pilot valve WV4 will be detected at the same time. The pressure limiting valve VDB is designed as an electrically adjustable pressure limiting valve with a pressure limiting function.

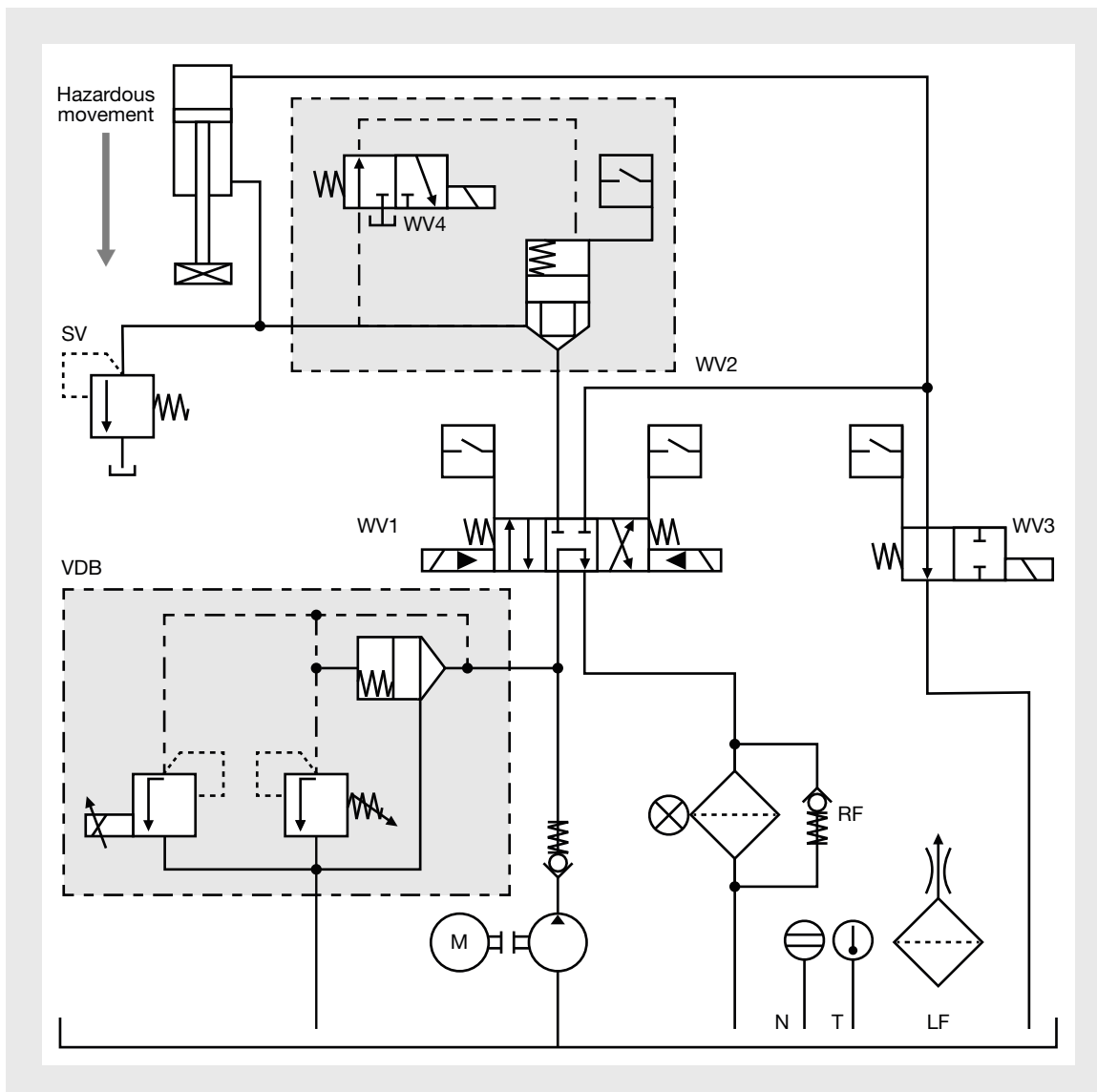

Example of hydraulic circuit (Cat 4, PL e)



9

Appendix



▶ 9 Appendix

9	Appendix	
9.1	Index	9-3
9.2	Exclusion of liability	9-13

▶ 9.1 Index

▶ Symbols, 0–9

1999/5/EC	3-16
2001/95/EC	3-16
2003/10/EC	3-16
2006/42/EC	3-5, 3-10, 3-11, 3-16, 3-17, 3-44, 3-53, 4-4, 4-6
2009/104/EC	3-80
2014/30/EU	3-16
2014/35/EU	3-16
2014/53/EU	3-16
3 contactor combination	5-3, 5-6, 7-24, 7-25
89/686/EEC	3-16
β factor	3-31
λ_D	3-32
λ_{DD}	3-26
λ_{Dtotal}	3-26

▶ A

A, B and C standards	3-41, 3-43
Absence of feedback	5-22
Absolute pressure	8-38
Access	3-7, 3-54, 4-3, 4-4, 4-5, 4-8, 4-9, 4-16, 4-18, 5-40, 7-17, 7-31, 7-41, 8-17
Accreditation Directive 765/2008/EC	3-75
Active optoelectronic protective devices	4-16
Actuator	5-3, 5-4, 5-6, 5-31, 5-41, 6-6
Adjustable guards restricting access	4-5
Air bubble cavitation	8-43
Air spring	8-25, 8-26
Analogue processing	5-12, 5-20
ANSI (American National Standards Institute)	3-18, 3-41
Anthropometric data	3-28
Application area	3-17, 3-24, 3-29, 3-33
Application layer	6-8, 6-11
Approach speed	3-19, 3-28, 4-7, 4-16, 8-25
Assembled machinery	3-6
Assembly instructions	3-10, 3-14
Assembly of machines	3-6
Assessment	3-14, 3-26, 3-31, 3-67, 4-23, 8-5
Assessment procedure	3-11
Associação Brasileira de Normas Técnicas (ABNT)	3-44
Asynchronous motor	7-24, 7-27
Austrian Standards Institute (ÖNorm)	3-18
Authorised representative	3-6, 3-9, 3-75
Automatic	5-18
Automation technology	5-11, 5-22, 5-28, 5-30, 5-36, 6-6
Axes	5-19, 5-36, 7-7, 7-14, 7-16, 7-17, 7-18, 7-20, 7-26, 7-41

▶ B

B10 _d	3-26, 3-31, 3-60, 3-68, 5-26, 7-31, 7-34
Basic drive module (BDM)	7-10
Basic physical knowledge	8-37
Basic safety standards and technical safety standards	7-28
Bernoulli's equation	8-41
BG (Federal law)	5-11, 5-30
BGIA (The German Institute for Occupational Safety and Health)	3-23
Block diagram	7-29, 7-31, 7-33, 7-35, 7-42
bmwfi	3-78
Body measurements	3-19
Bottom-up	3-70
Brake	7-20, 7-25, 7-30, 7-31, 7-32, 8-33, 8-34, 8-35
Brake test	7-20
Braking	7-15, 7-16, 7-18, 8-27, 8-33
Braking ramp	7-15, 7-16
British Standard (BS)	3-18
Broken shearpin	5-18
Bus scan time	6-7, 6-8
Bus systems	5-4, 5-21, 5-22,

▶ C

Calculation tool	3-24, 3-75
Calibration reports	3-79
CAN	6-11
CANopen	6-8, 6-11
CANopen standard	6-11
Category	3-27, 3-32, 3-65, 3-68, 3-69, 4-20, 7-6, 7-12, 7-15, 7-16, 7-32, 7-37, 8-58, 8-59, 8-60, 8-61, 8-62, 8-63
Categories, classification	
- Performance level b	8-59
- Performance level b	8-60
- Performance level d	8-61
- Performance level e	8-62, 8-63
Cavitation	8-43
CCC	3-47
CCF factor	3-26, 3-31
CE mark	3-5, 3-10, 3-11, 3-15, 3-40, 3-42, 3-51
CE marking	3-5, 3-6, 3-7, 3-10, 3-12, 3-15, 3-17, 3-53, 3-75
CEN	3-18, 3-41, 3-42
CENELEC	3-18, 3-41, 3-42
Check valve	8-13, 8-30, 8-51
Circuit-based solutions	8-27
Circuit diagram	5-11, 8-25, 8-26, 8-29, 8-34, 8-35, 8-36, 8-44, 8-46, 8-47, 8-48, 8-49, 8-50, 8-51, 8-56

▶ 9.1 Index

- Circuitry5-3, 5-7
 Clamping cartridge.....8-33, 8-35
 CLC/TS 61496-2:2006 3-20
 CLC/TS 61496-3:2008 3-20, 3-37, 4-7
 CNC.....5-27
 Commissioning.....3-10, 3-40, 3-42, 3-44,
 3-49, 3-50, 3-57, 5-6, 5-39, 7-9
 Common cause factor.....3-31
 Communauté Européenne 3-5
 Communication error.....6-3
 Communication function 6-4
 Communication hierarchy 6-8
 Communication media 6-7
 Competent persons.....3-80
 Complete drive module (CDM).....7-10
 Component identification8-36
 Conduct contrary to safety.....4-24
 Configurable safety relays 5-4, 5-11, 5-12,
 5-13, 5-14, 5-15, 5-16,
 5-17, 5-18, 5-19, 5-20
 Configuration3-28, 3-57, 4-17, 5-26,
 7-22, 7-25, 8-25, 8-34,
 8-35, 8-39, 8-55
 Configuration tools5-11
 Conformity 3-5, 3-7, 3-12, 3-14, 3-76
 Conformity assessment.....3-5, 3-9, 3-14, 3-76
 Conformity assessment procedures 3-17
 Connection identification.....8-36
 Connection logic5-8
 Contact-based technology.....5-9, 5-13
 Continuity equation8-41, 8-45
 Control circuit diagrams3-14
 Control devices4-20, 4-24
 Controlled braking7-15
 Controlled loop status7-17
 Controlled stop7-12, 7-15, 7-16
 Controller (SRP/CS).....7-28
 Controller enable7-5, 7-6
 Controller inhibit4-21
 Controlling valves5-32
 Control of the oil flow8-45
 Control system 3-20, 3-29, 3-33, 3-67, 4-11,
 5-21, 5-22, 5-27, 5-29, 5-39, 6-6, 7-11
 Control technology5-3, 5-22, 5-24, 5-29
 Control valve5-20
 Control variable7-5, 7-6
 Converter.....4-21, 6-8, 7-4, 7-5, 7-6, 7-25, 7-31
 Counter no.6-12
 Couplings or fastenings.....8-56
 CRC.....6-12
 Cross muting5-16
 Crushing3-19, 4-7
 CSA (Canadian Standards Association)3-42
 Cycle initiation5-18
 Cycles of operations.....7-31
 Cyclical data channel6-11
▶ D
 DACH3-78
 Daisy chain wiring6-10
 DAkkS (German Accreditation Body)3-75, 3-78,
 3-79, 3-80, 3-81
 Danger prevention8-11
 Dangers3-14, 4-3, 4-8, 4-22, 4-26, 4-28,
 5-7, 5-30, 7-30, 8-5, 8-7, 8-8, 8-9, 8-10,
 8-12, 8-15, 8-16, 8-17, 8-19, 8-23, 8-28, 8-55
 DAP3-78
 Data security mechanism6-4
 DC_{avg}3-26
 DC value3-26, 3-70
 Decentralised safety technology6-3
 Declaration of conformity3-10, 3-14,
 3-17, 3-44, 3-45, 3-55, 3-59
 Declaration of incorporation3-10, 3-14
 Defeating safeguards4-20, 4-22, 4-24
 Design defect4-27
 Design of safeguards4-11
 Design principles3-21
 Detection of shorts across contacts5-21
 Deterministic hazards.....8-9, 8-15
 Diagnostic capability5-6
 Diagnostic coverage (DC).....3-26, 3-27, 3-60,
 4-14, 7-31, 8-32, 8-33
 Diagnostic data5-13
 Diagnostic purposes5-4
 Diagnostic test interval (T₂).....3-34
 Differential circuit.....8-50
 DIN3-18, 3-34
 DIN EN ISO 14118.....4-21
 DIN EN ISO 17020.....3-75
 Direction of approach.....3-28
 Direction of rotation.....7-7, 7-35
 Directives3-3, 3-4, 3-5, 3-12, 3-15,
 3-16, 3-40, 3-42, 3-43, 3-44,
 3-45, 3-51, 3-54, 3-64, 3-75
 Directives and laws in America3-40
 Directives and laws in Asia.....3-45
 Directives and laws in Australia.....3-49
 Directives and laws in New Zealand3-50
 Direct safety technology.....8-15, 8-16
 Disconnection from voltage.....5-4, 5-10
 Distance monitoring3-55, 5-31
 DKD3-78
 Documentation3-7, 3-14, 3-48, 3-62, 3-66,
 3-67, 3-72, 4-13, 5-26, 8-4, 8-5
 Domestic law3-3

► 9.1 Index

- Doors..... 3-19
 d_{op}7-31, 7-34
 Downward movement 8-45
 Drag error detection 7-37
 Drive-integrated isolation 7-6, 7-9, 7-12, 7-19,
 Drive-integrated motion monitoring7-26, 7-36
 Drive-integrated safety... 4-21, 5-35, 7-3, 7-13, 7-18
 Drive-integrated safety technology 7-3
 Drive4-11, 4-21, 7-4, 7-12, 7-15, 7-18, 7-19,
 7-24, 7-25, 7-26, 7-27, 7-36, 7-37, 7-38,
 7-39, 7-40, 8-4, 8-25, 8-32, 8-37
 Drive bus7-3, 7-26
 Drive components7-22, 7-23
 Drive electronics7-4, 7-23
 Drive environment 5-19
 Drive pump 8-52, 8-53, 8-54
 Drive system..... 3-38, 5-19, 7-3, 7-4, 7-6,
 7-7, 7-10, 7-11, 7-12, 7-25
 Drive technology 3-54, 4-21, 5-36, 5-37, 7-6,
 7-15, 7-16, 7-22, 7-23, 8-3
 Duration of exposure to hazard..... 3-25
- **E**
- EC Declaration of Conformity..... 3-5, 3-6, 3-9,
 3-10, 3-15, 3-17, 3-53, 3-75
 Electrical codes (NEC)..... 3-41
 Electrical safety 3-33
 Electronic cam disk (synchronous motion)..... 7-26
 Electronics 3-18, 5-6, 5-37
 Electronic safety relays..... 5-4, 5-6, 5-9
 Electrosensitive
 Elliptical curve (resulting motion)..... 7-26
 EMC-attributable disturbances 6-4
 EMC Directive.....3-12, 3-16
 EMC load.....6-7
 EMC requirements.....3-20, 3-36
 Emergency stop 3-81, 5-3, 5-6, 5-28,
 5-32, 5-37, 7-28, 8-36
 Emergency stop devices 7-34
 EN/IEC 615087-7, 7-11
 EN/IEC 61800-5-27-3, 7-6
 EN 1005-1 to -4:2008..... 3-19
 EN 1005-5:2007 3-19
 EN 1010 4-24
 EN 1037 4-21
 EN 1037:2008 3-19
 EN 1088 3-36
 EN 1088:2008 3-19
 EN 12453:2000 3-19
 EN 292 3-19
 EN 349:1993+A1:2008 4-7
 EN 349:2008 3-19
 EN 415 7-28
 EN 547-1 to -3:2008..... 3-19
 EN 574:2008 3-19
 EN 60204-1 3-33, 7-12, 8-55
 EN 60204-1:20103-20, 3-33
 EN 60947-5-1:2009 3-20
 EN 60947-5-2:2012 3-20
 EN 60947-5-3:2005 3-20
 EN 60947-5-4:2003 3-20
 EN 60947-5-5:2013 3-20
 EN 60947-5-6:2001 3-20
 EN 60947-5-7:2003 3-20
 EN 60947-5-8:2006 3-20
 EN 60947-5-9:2007 3-20
 EN 61326-3 Parts 1+2:2008.....3-20, 3-36
 EN 61496-1:2010 3-20
 EN 61496-3:2003 3-20
 EN 61508...3-23, 3-29, 3-33, 3-34, 3-35, 3-38, 3-67
 EN 61508 Parts 1-7:20103-20, 3-33
 EN 61511 Parts 1-3:20043-20, 3-29
 EN 61784-3:20103-20, 3-23
 EN 61800-5-2:20073-20, 3-38
 EN 61800 7-10, 7-11, 7-12, 7-13
 EN 62061 3-24, 3-29, 3-32, 3-33,
 3-67, 3-68, 3-72, 4-11
 EN 62061:20163-20, 3-29
 EN 692 7-28
 EN 693 7-28
 EN 953:2009 3-19
 EN 954-1 3-9, 3-67, 4-20
 EN 999 3-28
 Enable principle 5-24
 Enabling switch5-7, 7-34
 Encoder 5-19, 7-7, 7-8, 7-9, 7-36,
 7-37, 7-38, 7-40
 Encoder line.....5-19, 7-25
 Encoder signal..... 5-19, 7-7, 7-37, 7-38
 Encoder systems..... 7-7, 7-8, 7-9, 7-19, 7-22, 7-25
 Encroachment from behind.....4-18, 4-19
 Energy supply 4-21, 5-3, 7-30, 8-55
 EN ISO 10218-1 3-52, 3-53, 7-28
 EN ISO 11161:2010.....3-19, 3-39
 EN ISO 12100-1 and 23-19, 3-21
 EN ISO 12100:2010.....3-19, 3-21
 EN ISO 13849-1 3-9, 3-21, 3-23, 3-24, 3-25,
 3-26, 3-27, 3-29, 3-33, 3-38, 3-54, 3-60,
 3-61, 3-62, 3-63, 3-64, 3-66,3-67, 3-68,
 3-74, 3-75, 4-11, 5-14, 5-19, 5-26, 7-12,
 7-28, 7-29, 7-31, 7-32, 7-34, 8-28
 EN ISO 13849-1:2009 3-19
 EN ISO 13849-2 3-24, 3-66, 3-67, 3-73,
 EN ISO 13849-2:20123-19, 3-24
 EN ISO 13855 3-28, 3-57, 4-15, 4-16,
 4-17, 7-33, 8-60

▶ 9.1 Index

- EN ISO 13855:2010..... 3-19, 3-28, 4-7
 EN ISO 13857:2008..... 3-19, 3-28, 4-7
 EN ISO 14119:2013.....3-36, 4-7
 EN ISO 14120:2015..... 4-7
 Environmental requirements.....3-73
 Error reaction function..... 7-25
 Error states5-13
 ESPE 4-16, 4-17, 4-19
 Ethernet-based.....5-15
 Ethernet-based fieldbus system 6-6
 Ethernet.....5-15, 5-22, 6-4, 6-6, 6-7, 6-8,
 6-9, 6-10, 6-11, 6-12, 6-13, 6-14
 Ethernet technology6-8, 6-13
 European co-operation for Accreditation (EA)....3-78
 Ex area.....5-10
 European Union.....3-3, 3-4
 Evaluation logic 5-4
 Excessive functionality 4-27
 Exhaust throttles8-34
 Exposure3-24
 External commands 7-42
 External motion monitoring
 with one standard encoder..... 7-37
 External motion monitoring
 with safe encoder 7-40
 External motion monitoring with
 standard encoder and proximity switch..... 7-38
 External motion monitoring with
 two standard proximity switches..... 7-39
- ▶ **F**
 Failsafe 8-12
 Failsafe principle7-3, 7-25
 Failure mode.....8-30
 Fault rectification procedure.....4-25
 Fault simulation (safety check).....3-75
 Fault tolerance.....3-32
 Feasibility tests..... 7-7
 Federal Act on Accident Insurance (AIA).....3-80
 Fibre-optic (FO) cable communication..... 6-7
 Fibre-optic cable6-7, 6-13
 Fieldbus.....3-20, 3-23, 5-13, 5-24, 6-10, 7-7, 7-9
 Fieldbus modules 5-13
 Fieldbus standard.....6-11
 Fieldbus system 5-13, 6-6, 6-14
 Filtration of the hydraulic fluid (RF)..... 8-57
 Fittings.....8-43
 Fixed guards..... 3-19, 4-6, 4-7, 4-8, 4-9, 4-11
 Fixed pump8-43, 8-52
 Flow forms..... 8-41
 Fluid flow 8-51
 Fluid power system8-37, 8-57
 Force and path transmission..... 8-40
- Freedom of movement 3-17
 Frequency converter7-4, 7-10, 7-23, 7-27
 Friction shear stress 8-42
 Functional safeguard..... 4-21
 Functional safety 3-17, 3-20, 3-24, 3-29, 3-33,
 3-38, 3-73, 4-21, 5-40, 7-3,
 7-10, 7-15, 7-16
 Function blocks..... 3-61, 3-63, 3-66, 5-25, 5-33
 Function elements..... 5-25
 Function test..... 3-73, 3-75, 8-56
- ▶ **G**
 Gear pump8-52, 8-54
 German Institute for Standardization (DIN) 3-18
 German Product Liability Act (ProdHaftG) 2-1
 German Product Safety Act4-22, 4-27
 GOST-R certification..... 3-45
 Gravitational pressure 8-39
 Guard locking3-36, 4-5, 4-9, 4-11
 Guards..... 4-4, 4-5, 4-6, 4-8, 4-9,
 4-11, 4-14, 4-16, 4-27, 4-28, 8-17
- ▶ **H**
 Harmonisation3-3, 3-4, 3-16, 3-18
 Harmonised standard.....3-3, 3-4, 3-12, 3-40,
 3-41, 3-42, 3-43, 3-44, 3-45,
 3-49, 3-50, 3-51, 3-67, 8-9
 Hazard 3-8, 3-14, 3-16, 3-21, 3-25,
 3-70, 4-4, 4-6, 4-8, 4-15, 4-16, 4-17,
 4-21, 4-26, 4-28, 5-3, 5-40, 7-6, 7-15, 7-18,
 7-19, 7-25, 8-5, 8-8, 8-9, 8-15, 8-16, 8-19
 Hazard assessment..... 3-73
 Hazard exposure (frequency)3-25, 3-30
 Health and safety requirements 3-12, 3-14, 3-17
 High-end safety solutions..... 7-3
 High Demand Mode 3-29
 Hold 8-31
 Holding brake 7-20, 7-24, 7-31, 7-32, 8-33
 Holding brakes and service brakes.....7-20, 7-30
 h_{op} 7-31, 7-34
 Hose colours 8-36
 Hose cross-sections..... 8-36
 Hose numbers 8-36
 Hydraulic accumulator 8-56
 Hydraulic circuit..... 8-44, 8-45, 8-46
 Hydraulic controller8-57, 8-63
 Hydraulics.....3-33, 5-28, 8-3, 8-23,
 8-25, 8-37, 8-42, 8-59
 Hydraulic system..... 8-44
 Hydraulic systems with hydraulic accumulator ... 8-56
 Hydraulic work 8-40
 Hydro pump 8-43
 Hydrostatic energy transfer 8-37

▶ 9.1 Index

- ▶ **I**
- I/O interconnection.....7-9, 7-26
 - IEC/TR 62061-1:2009.....3-20
 - IEC/TR 62685:2010.....3-20, 3-23
 - IEC/TS 62046:2008.....3-20, 3-37
 - IEC 60204-1.....7-14, 7-15, 7-16
 - IEC 61131.....5-25
 - IEC 61496-2:2013.....3-20, 3-37
 - IEC 61508.....3-18, 3-34, 3-36, 6-7, 6-11, 8-9
 - IL (Instruction List).....5-21
 - Import.....3-7
 - Importer.....3-48
 - Incorrect message sequence.....6-4
 - Incremental encoder.....7-27
 - Indirect safety technology.....8-17
 - Industrial communication networks.....3-20, 3-23
 - Industrial Safety and Health Law (Japan).....3-46
 - Industrie 4.0.....5-38, 5-40, 5-41
 - Informative safety technology.....8-15, 8-19
 - Injury, severity of.....3-25
 - Inputs/outputs.....5-11, 5-21
 - Installation.....3-56, 5-7
 - Installation process.....5-7
 - Integrated fault detection.....4-13
 - Integrated safe shutdown path.....7-14, 7-23
 - Interfaces/communication.....7-22
 - Interlock.....4-4, 4-5, 4-9, 4-11, 4-24, 4-25, 4-27, 4-29, 5-28, 8-55
 - Interlocking concept
 - for special operating modes.....4-25
 - Interlocking device.....3-19, 3-36, 4-5, 4-7, 4-23
 - Intermediate circuit.....7-5, 7-6, 7-23
 - International Accreditation Forum (IAF).....3-78
 - International Electrotechnical Commission (IEC).....3-18
 - International Laboratory Accreditation Cooperation (ILAC).....3-78
 - International Organization for Standardization (ISO).....3-18
 - Interruption.....5-4, 5-37, 7-6, 7-12, 8-16
 - Inverted rectifier.....7-5, 7-6
 - I_s4-15
 - $I_{Smax}(I)$4-15
 - I_{Smax}4-15
 - ISO/IEC 17020.....3-79
 - ISO/IEC 17025.....3-79
 - ISO/OSI reference model.....6-9
 - ISO/TR 23849:2010.....3-20
 - ISO 14118:2000.....3-19
 - ISO 14119.....3-19, 3-36, 4-9
 - ISO 15189.....3-79
 - ISO 9001 standard.....3-79
- ▶ **J**
- JIS standards (Japanese Industrial Standards).....3-46
 - Jog function.....7-18, 7-33, 7-34
 - Jog mode.....7-3, 7-18, 8-59
- ▶ **L**
- Laser scanners.....3-37, 4-19, 5-10, 5-16
 - Law of friction.....8-42
 - LD (Ladder Logic/Ladder Diagram).....5-21
 - Leakages.....8-23, 8-55
 - Lifecycle.....3-33, 3-38, 3-63, 7-22
 - Lifecycle phases.....3-14
 - Lift stops.....8-56
 - Light beam devices.....3-37, 3-75, 4-6, 4-8, 8-17, 8-25, 8-35
 - Light curtains.....3-37, 3-59, 3-75, 4-17, 5-6
 - Limbs.....3-19, 3-28, 4-7
 - Limit value.....3-53, 3-56, 3-57, 3-58, 3-59, 3-65, 5-19, 7-3, 7-9, 7-12, 7-14, 7-15, 7-16, 7-17, 7-18, 7-19, 7-24, 7-25, 7-26, 8-5, 8-55
 - Limit value violation.....7-12, 7-14, 7-19, 7-42
 - Low-noise design.....8-55
 - Low demand mode.....3-29
 - Low Voltage Directive.....3-12, 3-16
- ▶ **M**
- Machine availability.....7-6
 - Machine components.....3-10
 - Machine cycle.....7-34
 - Machinery.....3-5, 3-6, 3-7, 3-8, 3-9, 3-10, 3-11, 3-12, 3-14, 3-15, 3-16, 3-17, 3-19, 3-20, 3-21, 3-23, 3-24, 3-25, 3-28, 3-29, 3-33, 3-36, 3-37, 3-39, 3-40, 3-41, 3-42, 3-43, 3-44, 3-45, 3-46, 3-47, 3-48, 3-49, 3-50, 3-51, 3-53, 3-55, 3-56, 3-57, 3-58, 3-64, 3-67, 3-68, 3-69, 3-70, 3-72, 3-73, 3-75, 3-80, 4-3, 4-4, 4-5, 4-7, 4-8, 4-11, 4-12, 4-15, 4-16, 4-18, 4-19, 4-21, 4-22, 4-24, 4-25, 4-27, 4-29, 5-3, 5-4, 5-6, 5-7, 5-10, 5-14, 5-16, 5-22, 5-26, 5-27, 5-28, 5-31, 5-32, 5-35, 5-37, 5-38, 5-40, 5-41, 6-8, 6-14, 7-3, 7-7, 7-9, 7-12, 7-23, 7-25, 7-28, 7-30, 8-3, 8-4, 8-5, 8-7, 8-8, 8-9, 8-12, 8-15, 8-16, 8-17, 8-19, 8-23, 8-24, 8-25, 8-27, 8-28, 8-35, 8-36, 8-55, 8-56, 8-60
 - Machinery Directive.....3-5, 3-6, 3-7, 3-8, 3-9, 3-10, 3-11, 3-12, 3-14, 3-15, 3-16, 3-17, 3-19, 3-24, 3-29, 3-41, 3-43, 3-44, 3-45, 3-47, 3-49, 3-50, 3-53, 3-81, 4-4, 4-7, 8-3, 8-9, 8-35
 - Annex I.....3-10, 3-12, 3-44
 - Annex II B.....3-10
 - Annex IV.....3-10
 - Annex VI.....3-10

▶ 9.1 Index

- Mains contactor 7-5
Maintenance unit 8-24, 8-27, 8-29, 8-36
Manipulation of safeguards 4-22
Manual start-up valve 8-27
Manual valve 8-27
Manufacturer 3-3, 3-4, 3-5, 3-6, 3-7, 3-10, 3-12,
3-14, 3-15, 3-23, 3-33, 3-38, 3-40, 3-41, 3-42,
3-44, 3-49, 3-50, 3-51, 3-54, 3-56, 3-60,
3-62, 3-63, 4-22, 4-24, 4-26, 4-27, 5-11, 5-26,
5-31, 7-11, 7-25, 7-31, 7-39, 7-40, 8-9, 8-35
Manufacturing process 3-74, 5-30, 7-11
Master-slave system 6-6
Measurements 3-58, 3-74, 3-78, 6-6
Mechanical dangers 8-8, 8-10
Mechanical movements 7-7, 8-55
Mechanical spring 8-25, 8-30, 8-36
Mechanics 3-18, 3-33, 5-37, 5-38, 8-3,
8-25, 8-28, 8-36
Mechatronic units 5-29, 6-14
Message corruption 6-4
Message delay 6-4
Message insertion 6-4
Message loss 6-4
Message repetition 6-3, 6-4
Microprocessor technology 5-6, 5-9
Minimum distances 3-19, 4-7, 4-17, 8-16
Minimum speed 7-18
Minimum test interval (T_1) 3-34
Mission time (T_1) 3-34
MLA = Multilateral
Recognition Arrangement 3-78
Modularisation 5-27, 5-29, 5-38
Modular machine design 6-14
Monitoring function 5-4, 5-18, 5-22, 5-28, 7-16,
7-18, 7-25, 7-36, 7-37, 7-38, 7-39, 7-40
Monitoring obligation 4-27
Monitoring the direction of rotation 5-32
Motion 5-27, 5-28, 5-29
Motion control 4-21, 7-4, 7-26
Motion control system 7-26
Motion generation 7-4, 7-12
Motion monitoring 7-4, 7-9, 7-24, 7-25,
7-26, 7-27, 7-36, 7-37, 7-38, 7-39, 7-40
Motion monitoring with external devices 7-36
Motor 7-3, 7-4, 7-5, 7-6, 7-7, 7-9,
7-10, 7-12, 7-14, 7-15, 7-16,
7-17, 7-19, 7-24, 7-25, 7-31
Motor contactor 7-5, 7-6
Motor current 7-19
Motor feedback 7-7
Movable guards 3-19, 4-5, 4-7,
4-9, 4-11, 4-12, 4-14, 4-15
Movable safeguards 5-4
MRA = Mutual Recognition Agreement 3-78
MS6-SV 8-28, 8-29
MTTF_d – Mean time to dangerous failure 3-26,
3-27, 3-31, 3-60, 3-68, 5-26, 7-31,
7-32, 7-34, 7-37, 7-38, 7-39
Multi-turn encoder 7-7
Muting 4-18, 7-35
Muting function 4-18, 5-10, 5-16
Muting lamp 5-16, 5-17
- ▶ **N**
N/C contacts 4-12, 7-6
Navier-Stokes equation 8-41
NC controller 7-26
NFPA (National Fire Protection Association) 3-41
NFPA 79 3-39, 3-41
NFPA 79:2008 3-39
NFPA 79:2013 3-20
Noise Directive 3-16
Noise immunity 3-36
Noise immunity requirements 3-36
Non-safety-related communication function 6-4
Normally energised mode 8-58
Normally open principle 4-19
Normal operation 4-27, 8-29
Notified body 3-17
- ▶ **O**
Obligation for certification 3-45, 3-47
OD – ordinary device 6-10
Official Journal of the EU 3-3, 3-4
Old machine 3-7
Opening frequency 4-28
Operating manual 3-6, 3-14, 3-75, 4-3,
4-22, 4-25, 8-4, 8-19, 8-35
Operating mode selection 5-32
Operating pressure 8-24, 8-26, 8-27, 8-35, 8-55
Operating pressure range 8-55
Operating temperatures 8-55
Operation 3-39, 3-40, 4-3, 4-21, 6-11, 7-12,
7-14, 7-17, 7-25, 8-36, 8-43
Operator 3-6, 3-39, 3-43, 3-44, 3-46, 3-49, 3-50,
3-73, 3-75, 4-26, 4-27, 5-7, 5-26, 8-25
Optocoupler 7-5, 7-6, 7-23
OSHA (Occupational Safety
and Health Organisation) 3-18, 3-40, 3-42
OSHA standards 3-40
OSI reference model 6-9
OSSD 4-13, 4-15
Overall circuit 7-29, 7-32, 7-34, 7-35, 7-42
Overpressure 8-38
Overrun 5-59, 7-3, 7-19, 7-23, 8-25, 8-35
Own use 3-7

▶ 9.1 Index

▶ P

Packet Identifier 6-12
 Parallel circuit 8-47, 8-49, 8-50
 Parameter tool 5-12
 Partly completed machinery 3-6
 Parts of the body 3-19, 3-28, 4-7, 4-16, 8-16
 Passport to Europe 3-5
 PDS/Safety-related (SR) 7-10
 Peak current I_s 4-15
 Pendulum motion 5-32
 Performance level 3-24, 3-25, 3-26, 3-57, 3-60,
 3-61, 3-62, 3-63, 3-68, 3-72, 3-75, 5-14,
 7-28, 7-29, 7-30, 7-31, 7-32, 7-34, 7-35,
 7-37, 7-38, 7-39, 7-40, 7-42, 8-28, 8-29,
 8-32, 8-33, 8-58, 8-59, 8-60, 8-61, 8-62, 8-63
 Performance level PL_r 3-24, 3-25, 3-27,
 3-65, 3-68, 3-71
 Personal Protective Equipment Directive 3-16
 PFD (probability of failure on low demand) 3-31
 PFH_D 3-27, 3-32, 3-60, 7-32
 Physical performance 3-19
 PID (packet identifier) 6-12
 Piston forces 8-38, 8-44, 8-49
 Piston pressure force 8-38
 Piston speed 8-39, 8-45, 8-49
 PL 3-25, 3-26, 3-27, 3-57, 3-68, 3-70, 4-11,
 4-13, 4-14, 7-23, 7-29, 7-32, 7-34, 8-28
 Placing on the market 3-17
 PLC controller 5-21, 5-33
 PL_e 3-61, 3-65, 4-13, 7-38, 7-39, 7-40, 8-62, 8-62
 PL graph 3-25, 3-27, 7-32
 PMCprotego DS 5-35
 Pneumatic components 8-23, 8-24
 Pneumatics 3-33, 5-28, 8-3, 8-23, 8-25,
 8-26, 8-27, 8-28, 8-32, 8-36
 PNOZ 5-3, 8-29
 PNOZelog 5-9
 PNOZmulti 3-62, 4-21, 5-4, 5-32, 5-33
 PNOZsigma 5-6
 Positioning 7-26
 Positioning control 7-26
 Position monitoring 5-4, 5-20, 7-19
 Position window 7-12, 7-17, 7-19
 Possibility of defeat 3-36, 4-17, 4-18
 Power contactor 5-4
 Power drive system (PDS) 7-10
 Press applications 5-18
 Press safety valve 5-18
 Press stroke 5-31
 Pressure 3-56, 4-23, 4-27, 5-20, 8-24,
 8-25, 8-26, 8-35, 8-36, 8-37,
 8-38, 8-39, 8-40, 8-43, 8-44, 8-48,
 8-49, 8-50, 8-54, 8-55, 8-56

Pressure drops 8-43
 Pressure intensifier 8-40
 Pressure limitation 8-24, 8-57, 8-58
 Pressure limitation within the system (VDB) 8-57
 Pressure losses 8-43
 Pressure sensitive mats 4-17, 4-19
 Pressure source 8-36
 Pressure transmission 8-40
 Pressure values 8-24
 Presumption of conformity 3-3, 3-4, 3-24, 3-29
 Primary control 8-51
 Procedures used to attach and monitor 4-28
 Process data object (PDO) 6-11
 Productivity increase 5-22
 Product liability 2-1
 Product Safety Directive 3-16
 Product standards 3-36
 Programmable logic controller (PLC) 5-3
 Protective devices 4-5, 4-7, 4-8, 4-16, 8-17
 Protective equipment 3-37, 3-75, 3-80,
 4-7, 4-8, 4-16, 4-18, 5-18
 Protective fence 3-58, 4-6, 4-15, 4-17
 Proximity switch 4-13
 PSSu multi 5-33
 Publisher/subscriber principle 6-10

▶ Q

Quality assurance 3-79

▶ R

Radio Equipment Directive 3-16
 Range Monitoring 5-20
 Rated holding torque 7-31
 RC controller 7-26
 Reaction function 7-14, 7-19, 7-25
 Reaction times 3-59, 4-16, 4-17, 5-22, 5-24,
 7-3, 7-15, 7-16, 7-18, 7-23, 7-25, 7-42, 8-35
 Real-time communication 6-10
 Reduction factor 7-32
 Redundancy 4-13, 6-3, 6-5, 8-12, 8-13, 8-14
 Redundant design 5-6
 Reed contacts 4-15
 Reference variable 7-5, 7-6
 Relay 3-74, 4-15, 5-3, 5-6
 Relay circuits 5-3
 Relay technology 5-4, 5-6
 Required characteristics of guards
 and protective devices 4-4
 Residual risk 3-14, 4-26, 4-27, 8-9
 Restart 4-18, 4-21, 5-12, 7-6, 7-23, 8-54
 Retrofit 7-25
 Reynolds number 8-41
 RFID 4-13

► 9.1 Index

- Ring area8-49, 8-50
- Risk.....3-14, 3-24, 3-25, 3-30, 4-5, 4-26, 4-28, 4-29, 5-3, 8-5, 8-9, 8-19, 8-25, 8-31
- Risk analysis.....3-24, 3-30, 3-46, 4-22, 7-11, 7-18, 7-20, 7-23, 7-28, 7-30, 8-5, 8-9, 8-32
- Risk assessment 3-9, 3-10, 3-12, 3-13, 3-14, 3-57, 3-59, 3-61, 3-67, 3-68, 3-75, 8-9, 8-26
- Risk evaluation 3-19, 3-21, 3-22, 3-24, 3-27, 3-30, 3-32, 3-38, 4-17, 4-22, 8-9, 8-55
- Risk factors3-21
- Risk graph3-24, 3-25, 3-29, 3-30
- Risk minimisation3-67
- Risk reduction3-19, 3-21, 3-22, 3-55, 5-4, 8-5
- Root device6-10
- Rotary cam arrangement..... 5-18, 5-31, 5-32
- Rotary encoder.....6-8, 7-6, 7-7, 7-36, 7-38, 7-39, 7-40
- R_{Pmin} 4-15
- RSA3-18
- $R_{Smin(i)}$4-15
- RTFL (Real Time Frame Line) 6-8, 6-9, 6-10
- RTFN (Real Time Frame Network).....6-8, 6-9
- Rule violation.....4-26
- Run monitoring.....5-18
- S**
- $S = (K \times T) + C$ 4-17
- $S = (K \times T)$4-15
- $S = K^* (t1 + t2) + C$ 4-16
- Sabotage4-24
- Safe-life8-12
- Safe absolute position.....7-7
- Safe acceleration range (SAR).....7-17, 7-36, 7-37, 7-38, 7-40
- Safe analogue processing.....5-20
- Safe brake control (SBC).....7-20
- Safe brake function7-20
- Safe brake test (SBT).....7-20
- Safe cam (SCA)7-19
- Safe camera-based solution7-41
- Safe camera systems.....3-37, 3-81, 4-16, 4-19, 4-20, 7-3
- Safe communication5-13, 5-15, 6-3, 6-11
- Safe condition7-3
- Safe controllers5-25, 7-9
- Safe control technology5-11, 5-28, 5-30, 5-31, 5-35, 5-36, 5-37,
- Safe decentralisation.....5-24
- Safe direction (SDI).....7-19, 7-35, 7-36, 7-37, 7-38, 7-40
- Safe drive function7-3
- Safe encoder5-19, 7-8, 7-40
- Safeguard3-19, 3-20, 3-28, 3-36, 3-37, 3-43, 3-57, 3-59, 3-67, 3-75, 3-80, 3-81, 4-3, 4-4, 4-5, 4-7, 4-8, 4-9, 4-11, 4-12, 4-14, 4-15, 4-16, 4-17, 4-18, 4-19, 4-21, 4-22, 4-24, 4-26, 4-27, 4-28, 4-29, 5-4, 5-18, 7-24, 7-41, 8-9, 8-16, 8-17, 8-18, 8-25, 8-55
- Safeguarding detection zones
with a safe camera-based solution7-41
- Safe limit value specification7-9
- Safe logic.....7-24
- Safely limited acceleration (SLA).....7-17, 7-36, 7-37, 7-38, 7-40
- Safely limited increment (SLI).....7-19
- Safely limited position (SLP).....7-19
- Safely limited speed (SLS).....7-18, 7-19, 7-33, 7-34, 7-36, 7-37, 7-38, 7-39, 7-40
- Safely limited torque (SLT).....7-19
- Safely reduced speed.....3-54, 3-55, 7-3, 7-18
- Safe motion7-3, 7-28
- Safe motion control4-21, 7-4
- Safe motion examples7-28
- Safe motion function7-17
- Safe motion monitoring.....7-4, 7-9, 7-26
- Safe operating stop (SOS).....7-16, 7-17, 7-36, 7-37, 7-38, 7-40
- Safe reset lock.....7-14, 7-23
- Safe separation7-4, 7-13
- Safe speed monitoring (SSM).....7-19
- Safe speed range (SSR)7-18, 7-36, 7-37, 7-38, 7-39, 7-40
- Safe stop 1 (SS1).....7-12, 7-14, 7-15, 7-16, 7-18
- Safe stop 2 (SS2).....7-12, 7-16, 7-17
- Safe stop function7-14, 7-19, 7-28, 7-32
- Safe stop function on vertical axes.....7-30
- Safe torque off (STO).....7-12, 7-14, 7-15, 7-16, 7-20, 7-23, 7-27, 7-36, 7-37, 7-38, 7-39, 7-40
- Safe torque range (STR)7-19
- Safety-related communication6-3, 6-4, 6-5, 6-7, 6-11
- Safety-related communication function6-4
- Safety-related message6-4, 6-5
- Safety Calculator PAScal.....3-24, 3-29, 3-57, 7-32
- Safety chain.....5-4, 5-18, 7-13, 8-31
- Safety characteristic data.....7-36
- Safety component.....3-6, 3-11, 3-40, 3-44, 3-48, 3-74, 8-23, 8-28, 8-56
- Safety controllers3-33, 3-60, 3-61, 3-63, 3-73, 5-4, 5-12, 5-15, 5-21, 5-22, 5-24, 5-25, 5-28, 5-30, 5-31, 5-32, 5-33, 5-35, 5-36, 6-3, 6-7, 6-12, 7-3, 7-14, 7-23, 7-24, 7-28

▶ 9.1 Index

- Safety distance..... 3-28, 4-6, 4-15,
4-16, 4-17, 7-16, 7-42
- Safety functions..... 3-9, 3-24, 3-27, 3-29, 3-38,
3-54, 3-60, 3-61, 3-63, 3-68, 3-69,
3-70, 3-71, 3-72, 3-73, 5-3, 5-4, 5-6,
5-9, 5-11, 5-19, 5-21, 5-26, 5-32, 5-36,
5-37, 7-3, 7-6, 7-7, 7-10, 7-11, 7-12,
7-13, 7-14, 7-15, 7-16, 7-17, 7-18, 7-19,
7-20, 7-21, 7-23, 7-24, 7-25, 7-26, 7-28,
7-29, 7-30, 7-31, 7-33, 7-36, 7-37, 7-38,
7-39, 7-40, 7-41, 7-42, 8-9, 8-60
- Safety gate 3-81, 4-9, 4-11, 4-12, 4-13,
4-15, 5-7, 5-9, 5-12, 5-19,
5-28, 5-32, 5-37, 7-3
- Safety guidelines 8-19
- Safety integrity 7-8, 7-9, 7-11, 7-13, 7-23
- Safety integrity level (SIL) 3-30, 3-68, 3-72, 4-11
- Safety lockout 7-16
- SafetyNET p 6-3, 6-4, 6-5, 6-6, 6-7, 6-8, 6-9,
6-10, 6-11, 6-12, 6-13, 6-14, 7-7
- Safety objectives 3-3, 3-4, 3-70, 8-28
- Safety principles..... 3-23, 3-69, 3-74, 8-26,
8-58, 8-59, 8-60, 8-61, 8-62
- Safety relays 3-33, 4-13, 4-15, 4-18,
5-3, 5-4, 5-5, 5-6, 5-7, 5-8, 5-9,
5-10, 5-11, 5-12, 5-13, 5-23, 5-25, 7-23,
7-24, 7-27, 7-36, 8-29, 8-30, 8-32, 8-33
- Safety requirements 3-9, 3-12, 3-14,
3-17, 3-40, 3-41, 3-42, 3-43, 3-44,
3-48, 3-51, 3-53, 3-72, 5-12, 5-14,
5-22, 5-40, 7-12, 7-25, 8-55, 8-56
- Safety switches
with integrated fault detection..... 4-13
- Screw connections..... 8-25, 8-26, 8-36
- Screw pump 8-53
- Secondary control 8-51
- Sector standard..... 3-29, 3-33, 3-36, 3-67, 7-11
- Segmented shutdowns 4-24
- Semiconductor outputs..... 5-4, 5-6
- Sensors 3-37, 3-59, 4-11, 4-12, 4-14, 4-18,
4-19, 5-4, 5-6, 5-16, 5-17, 5-31, 5-41,
6-6, 7-17, 7-24, 7-26, 7-36, 7-38, 8-32
- Sensor subsystem..... 7-38, 7-39
- Sequence valve 8-48
- Sequential muting 5-16
- Series circuit..... 4-14, 4-15, 8-47, 8-49
- Series connection..... 4-12, 7-28, 7-29,
7-31, 7-33, 7-35
- Service data objects..... 6-11
- Servo amplifier 7-4, 7-12, 7-14,
7-15, 7-23, 7-26, 7-28
- Servo and frequency converter 7-10
- Servo converter 7-25, 7-26
- Servo presses..... 5-31
- Set-up mode 5-18, 7-18, 7-19, 8-26
- Setpoint specification..... 7-6
- SFF 3-32
- Shutdown 4-18, 4-21, 5-3, 5-30, 5-35,
7-3, 7-14, 7-17, 7-18, 7-24, 7-25, 8-61
- Shutdown path 7-4, 7-5, 7-6, 7-14, 7-23, 7-24
- Significant change 3-8
- Significant modification 3-8
- Sin/cos encoder: $\sin^2+\cos^2=1$ 7-40
- Sine/cosine motor encoder 7-26
- Single axis 7-26
- Single stroke..... 5-18
- Sistema..... 3-75
- Slide stroke..... 5-31
- Small controllers..... 5-4, 5-6, 5-11, 5-12, 5-13,
5-14, 5-15, 5-16, 5-17, 5-18,
5-19, 5-20, 5-25, 5-32, 5-33, 536
- Smoothness 8-52
- Software tool 5-11, 5-32, 5-38
- SPDO..... 6-12
- Specifications 3-14, 3-63, 3-70
- Speed 3-20, 3-38, 5-4, 5-10, 5-12,
7-10, 7-12, 8-22, 8-43, 8-56, 8-59
- Speed control 8-45, 8-51
- Speed monitoring 4-21
- Speed threshold 7-17
- SRCF 3-70
- Standard encoder..... 7-8, 7-36, 7-37, 7-38
- Standards 3-3, 3-4, 3-12, 3-14, 3-16, 3-17,
3-18, 3-19, 3-21, 3-24, 3-36, 3-37, 3-41,
3-42, 3-43, 3-44, 3-45, 3-46, 3-47, 3-49,
3-50, 3-51, 3-53, 3-67, 3-72, 3-75, 3-76,
3-79, 3-81, 4-7, 4-9, 5-4, 5-18, 5-30,
5-36, 7-3, 7-28, 8-9, 8-36
- Standards Australia 3-49
- Standard sensors 7-38 7-39
- Standards for dimensioning of guards 4-7
- Standards for guards..... 4-7
- Standards for the design of protective devices
or electrosensitive protective equipment 4-7
- Standards institute 3-18
- Standstill..... 3-54, 5-10, 5-19, 7-3,
7-12, 7-14, 7-15, 7-16, 7-42, 8-60
- Standstill detection..... 7-15, 7-16
- Standstill position 7-16, 7-17
- Standstill threshold..... 7-12
- Statistical methods..... 3-24, 3-29
- Steam bubble cavitation 8-43
- Stochastic hazards..... 8-8, 8-12, 8-15
- Stop..... 4-5, 4-11, 5-4, 7-12, 7-14,
7-15, 7-16, 7-20
- Stop category..... 7-12, 8-30

▶ 9.1 Index

- Stop function 7-12, 7-14, 7-19, 7-28,
7-29, 7-30, 7-32, 7-34, 7-35
- Structural methods 3-24, 3-29
- Subscriber 6-7, 6-10, 6-14
- Suspended loads 7-20
- Switch position sensing 8-32
- Synchronisation 7-16
- Synchronous circuit 8-47
- System examination 3-26, 3-31, 7-22,
7-23, 7-24, 7-25, 7-26, 7-27
- ▶ T**
- t_{cycle} 7-31, 7-34
- Technical documentation 3-6, 3-14
- Technical specifications 3-14
- Telegram 6-3, 6-4, 6-11
- Telegram structure 6-12
- Terminal voltage 7-5
- Test results 3-14, 3-70
- TGA/DATECH 3-78
- Throttle check valves 8-34
- Time delay 7-15, 7-16
- Timeout 6-4
- T_m mission time 5-26
- t_{multi} 7-42
- Top-down 3-70
- Topology 6-8
- Torque measuring system 7-19
- Torque monitoring 5-36
- t_{ramp} 7-42
- Transition periods 3-3, 3-5, 3-17, 3-48
- $t_{\text{reac}} = t_{\text{multi}} + t_{\text{PMC}} + t_{\text{ramp}}$ 7-42
- $t_{\text{reac}} = t_{\text{PMC}} + t_{\text{ramp}}$ 7-42
- Two-cylinder control systems
with electric valves 8-47
- Two-hand control 5-6
- Two-hand control device 4-20
- Two-hand control devices 3-19, 4-17,
4-20, 8-17, 8-25
- Type C 3-80
- Type examination 3-17, 3-45, 3-48
- Types of cavitation 8-43
- TÜV 5-11, 5-30
- ▶ U**
- UDP/IP-based communication 6-9
- UDP/IP communication 6-8
- UL 3-18
- Unexpected start-up 3-19, 4-11, 4-21,
7-14, 8-27, 8-55
- Unintended restart 4-21
- Upgrade 3-8, 8-36
- U_{Pmax} 4-15
- Upward movement 8-44
- User requirements manual 3-7
- ▶ V**
- Validation 3-9, 3-14, 3-19, 3-24, 3-57, 3-59,
3-62, 3-67, 3-68, 3-69, 3-70, 3-71,
3-72, 3-73, 3-74, 3-75, 4-11, 5-26
- Validation of safety functions 3-29, 3-71, 3-72
- Valve cross-section 8-45
- Valves with defined switching position 8-56
- Vane pumps 8-54
- Variable pump 8-43
- Vent 8-27, 8-28, 8-29, 8-35
- Ventilation time 8-35
- Vertical axes 7-14, 7-25, 7-30
- Viscosity 8-22, 8-41, 8-42, 8-43, 8-56, 8-58
- Visualisation 5-27, 5-29
- V model 3-62, 3-66, 3-72
- ▶ W**
- Walking and hand speed 4-16, 4-17
- Wireless and antenna technology 6-7
- Wireless communication 6-7
- Wiring diagram 8-28, 8-29
- Wiring requirement 5-7, 5-8, 5-9,
5-14, 7-12, 7-23, 7-25

▶ 9.2 Exclusion of liability

Our safety compendium has been compiled with great care. It contains information about our company and our products. All statements are made in accordance with the current status of technology and to the best of our knowledge and belief. While every effort has been made to ensure the information provided is accurate, we cannot accept liability for the accuracy and entirety of the information provided, except in the case of gross negligence. In particular, it should be noted that statements do not have the legal quality of assurances or assured properties. We are grateful for any feedback on the contents.

All rights to this safety compendium are reserved by Pilz GmbH & Co. KG. We reserve the right to make technical changes. Copies may be made for internal purposes. The names of the products, goods and technologies used are trademarks of the respective companies.

Support

Technical support is available from Pilz round the clock.

Americas

Brazil
+55 11 97569-2804

Canada
+1 888-315-PILZ (315-7459)

Mexico
+52 55 5572 1300

USA (toll-free)
+1 877-PILZUSA (745-9872)

Asia

China
+86 21 60880878-216

Japan
+81 45 471-2281

South Korea
+82 31 778 3300

Australia

+61 3 95600621

Europe

Austria
+43 1 7986263-0

Belgium, Luxembourg
+32 9 3217575

France
+33 3 88104000

Germany
+49 711 3409-444

Ireland
+353 21 4804983

Italy, Malta
+39 0362 1826711

Scandinavia

+45 74436332

Spain

+34 938497433

Switzerland

+41 62 88979-30

The Netherlands

+31 347 320477

Turkey

+90 216 5775552

United Kingdom

+44 1536 462203

You can reach our international hotline on:

+49 711 3409-444
support@pilz.com

Pilz develops environmentally-friendly products using ecological materials and energy-saving technologies. Offices and production facilities are ecologically designed, environmentally-aware and energy-saving. So Pilz offers sustainability, plus the security of using energy-efficient products and environmentally-friendly solutions.

Energy
saving by Pilz



Presented by:

Pilz GmbH & Co. KG
Felix-Wankel-Straße 2
73760 Ostfildern, Germany
Tel.: +49 711 3409-0, Fax: +49 711 3409-133
E-Mail: info@pilz.com, Internet: www.pilz.com

In many countries we are represented by sales partners. Please refer to our homepage www.pilz.com for further details or contact our headquarters.

PILZ
THE SPIRIT OF SAFETY